

# SOIL CONSERVATION IN KENYA

ESPECIALLY IN SMALL-SCALE FARMING IN HIGH POTENTIAL AREAS  
USING LABOUR INTENSIVE METHODS

ISSUED FREE OF CHARGE BY  
THE SOIL CONSERVATION EXTENSION UNIT  
MINISTRY OF AGRICULTURE

ISRIC LIBRARY

KE - 1980.05

Wageningen  
The Netherlands

Scanned from original by ISRIC - World Soil Information, as ICSU World Data Centre for Soils. The purpose is to make a safe depository for endangered documents and to make the accrued information available for consultation, following Fair Use Guidelines. Every effort is taken to respect Copyright of the materials within the archives where the identification of the Copyright holder is clear and, where feasible, to contact the originators. For questions please contact [soil.isric@wur.nl](mailto:soil.isric@wur.nl) indicating the item reference number concerned.

SOIL CONSERVATION IN KENYA

ESPECIALLY IN SMALL-SCALE FARMING IN HIGH POTENTIAL AREAS  
USING LABOUR INTENSIVE METHODS

by

Carl G. Wenner 8.1.1980  
Farm Management Branch  
Project Management and Evaluation Division  
Ministry of Agriculture  
Nairobi



1st edition 1975, 2nd enlarged edition 1976, 3rd revised edition 1977, 4th revised edition 1978, 5th revised and enlarged edition May 1979. 6th revised edition January 1980

CONTENTS

	pages
I. Erosion processes and their preventive measures	2 - 19
II. Prediction of soil loss and choice of soil conservation measure	20 - 34
III. Soil conservation on cultivated land	
What is soil conservation ?	35 - 37
Cultural measures	38 - 49
Physical measures	50 - 107
IV. Soil conservation on grazing land	108 - 113
V. Agro-forestry	114 - 122
VI. The Agriculture Act	123 - 136
VII. Soil conservation in farm planning	137 - 145
VIII. Instructions to technical assistants	146 - 152
IX. Maps in soil conservation	153 - 160b
X. Instruments	161 - 183
XI. Literature on soil conservation	184 - 191
Appendix 1      Gully control	1 - 12
Appendix 2      Grass species	1 - 7
Appendix 3      Tree species	1 - 3
Appendix 4      Conversion tables	1 - 4
Alphabetical subject list	1 - 9

N. B.

This is not a textbook but a handout for technical assistants.  
It should be studied together with lectures on soil conservation.

I EROSION PROCESSES AND THEIR PREVENTIVE MEASURES

C O N T E N T S

	pages
1. Splash erosion (by raindrops)	3 - 4
2. Stream erosion (by flowing water of any quantity)	5
Rill erosion	6 - 7
Gully erosion	8 - 10 a
River erosion	11 - 13
3. Solifluction (flow of water saturated soil)	14
4. Slides (descent of a mass of earth)	15 - 16
5. Wind erosion	17 - 19



# 1. SPLASH EROSION (or raindrop erosion)

## The process of raindrop erosion

Raindrops cause erosion:

- 1) on slopes, but on level ground only to a limited extent
- 2) where there are fine-graded particles in the soil
- 3) when the size and velocity of falling raindrops exceed those of a rainfall of 2 mm/min (120 mm/h).

The process is as follows:

- a) a raindrop falls hitting the ground
- b) it makes a tiny "crater" in the ground
- c) and it causes a splash of fine soil particles outwards from the crater to a distance of 1/2-1 m



Splash erosion is the most important erosion process on crop land containing fine soil particles. Clay soil, which is fairly resistant to erosion by flowing water, can easily be eroded by rain drops. The process starts with detachment of the clay particles, which permits the splash movement. The detachment is closely related to the shear strength of the clay.

On a slope, more particles are splashed downhill than uphill, causing erosion and transportation of soil even on short slopes (e.g. on sloping ground between terraces):

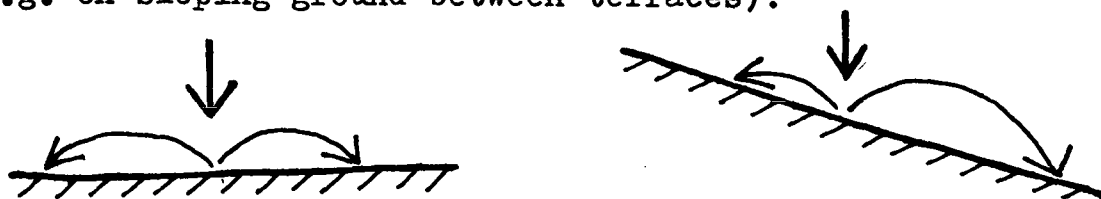

Splash erosion removes the fine particles from the surface of the soil, causing a lowering of the surface of the ground; removing first the topsoil, and later also the subsoil. If many coarse soil particles are present (pebbles and stones), the removal of the finer particles creates an erosion pavement, which however is usually broken down by further cultivation:

- a) soil with coarse particles
- b) splash erosion has caused an erosion pavement

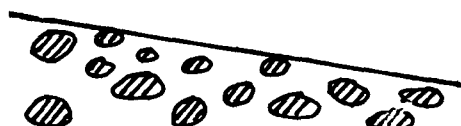

Rain of less than 20-30 mm/h does not cause any erosion. Research (in Upper Volta) has shown that even rainfall of up to 90 mm/h was rarely erosive, but rainfall exceeding 120 mm/h always caused erosion. In Kenya, very intensive rain causing splash erosion may not occur more than 2-3 times per year.

More intensive rain has drops of larger size and higher velocity. In normal rain one drop can be 1 mm in diameter, falling 4 m/s, but a drop in heavy rain can be 5 mm in diameter, falling 10 m/s. The energy of this drop is 500 times greater than the energy of the 1 mm drop.

Splash erosion can occur without any superficial flow of rainwater. On the other hand, runoff on a slope of clay or loam can not cause much erosion without the detachment of particles through rain drop erosion.

The splash erosion involves detachment and transportation of soil particles in quantities bigger than you could ever imagine. Measurements (in Upper Volta) have indicated a transportation of more than 50 tons/acre/year. Measurements (in Hawaii) have shown a splash movement of soil of 14 kg/sq.m during one single storm.

Splash erosion is most pronounced on bare ground when the rainy season starts. The peak runoff comes later, when the ground has been saturated with water. Both erosion and runoff decrease during the later part of the rainy season, when vegetation has developed.

#### Preventive measures for splash erosion

- 1) Protecting the ground from large raindrops
  - a) Good farm management: Sufficient application of fertilizers with subsequent high production can reduce the soil loss, as larger plants and their leaves protect the soil better.
  - b) Crop residue left on the shamba as a cover protects the soil.
- 2) Reducing the slope
  - a) Contour ploughed furrows prevent the splash of soil downhill.
  - b) Bench terraces give more or less level ground.

## 2. STREAM EROSION

Stream erosion occurs when the velocity of flowing water exceeds a critical limit:

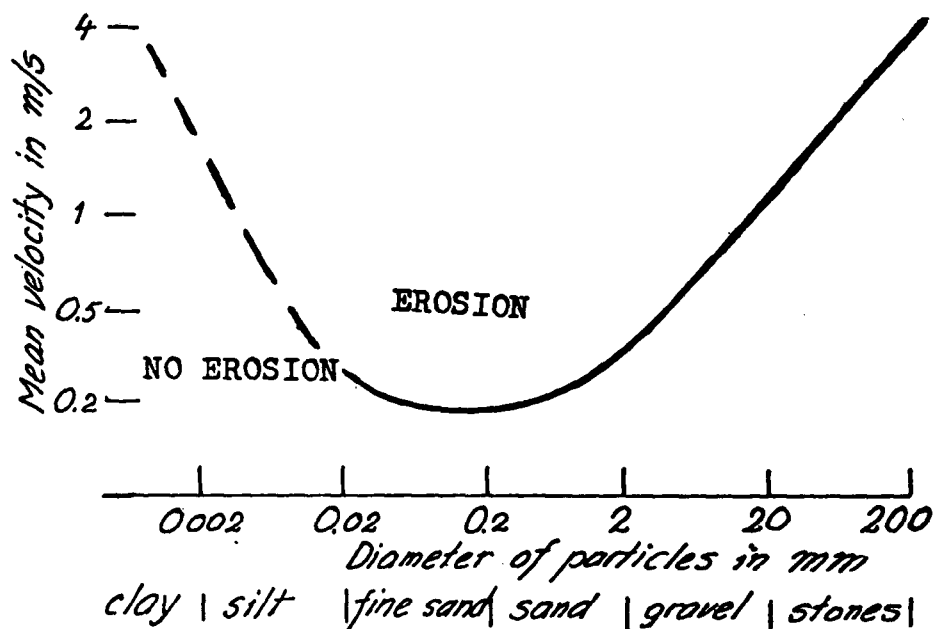

The graph shows that the most erodible soils are silt-sand which are eroded at about 0.2 m/s (in nature different sizes of particles, good compaction and chemical precipitations holding the particles make this threshold value higher, often upwards of 1 m/s). In coarser soils (the right hand side of the graph) higher velocities are needed to move the larger soil particles (the erosion power increases with the square of the velocity of the water flow, e.g. if the velocity of the water is increased from 1 to 2 m/s, it can erode particles 4 times larger). In clay soils (the left hand side of the graph) cohesion of the particles prevents erosion detaching them. However, cracks in the clay facilitate the removal of the particles.

Rather often soils can have their pores filled up by chemical precipitations (e.g. compounds of iron or calcium carbonate), giving the soil rocky and erosion resistant properties.

The different types of stream erosion are:

- 1) rill erosion
  - 2) gully erosion
  - 3) river erosion.
- } wash erosion

Rill and gully erosion are, together with splash erosion, the most common constituents of what is called soil erosion. This erosion is often, and wrongly, confused with river erosion.

Sheet erosion is the result of raindrop erosion and rill erosion.

1. Rill erosion

The process of rill erosion:

When the rate of rainfall exceeds the rate of infiltration of water into the ground, superficial flows will start. Usually many small rill flows furrow the ground, causing sheet or wash erosion.

On steep slopes the velocity of the rill flows will be higher than on medium slopes. The amount of erosion

(E) is not proportional to the steepness of the slope (S in%) but increases more rapidly:  $E = S^2$  (see graph a below).

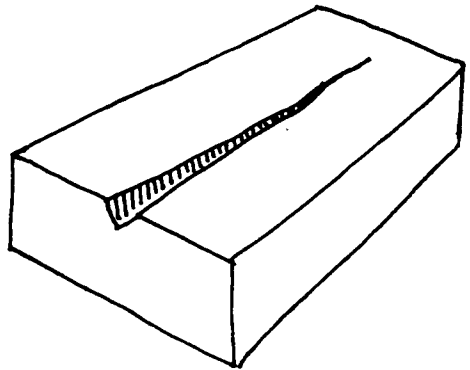

On long slopes the quantity of water will be larger, as also will the velocity and the depth of the rill flows. This will result in scour erosion. The soil loss per unit area (E) increases with the length of the slope but not proportionally:  $E = L^{0.5}$  or  $E = \sqrt{L}$  (see graph b).

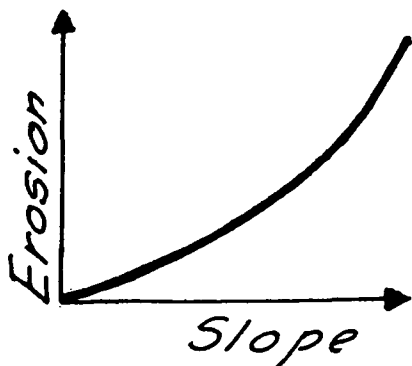

Graph a

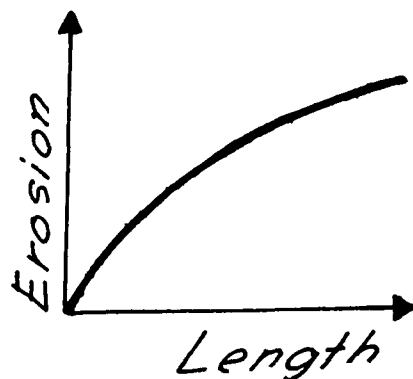

Graph b

Preventive measures for rill erosion

- 1) Contour farming means planting, tillage and other operations along the contour. Farming down the slope creates water flows flowing faster and faster down the slope, initiating rill erosion. But in contour farming ridges of earth hold up the water, thus preventing rill erosion (see the figure on p. 43).
- 2) Strip cropping (also called contour strip cropping) combined for example with a rotation of grass and crops. When water from a strip of maize reaches a strip of grass, it will be distributed in the grass, the speed reduced and silt deposited. The figures below show strip cropping in Kenya:

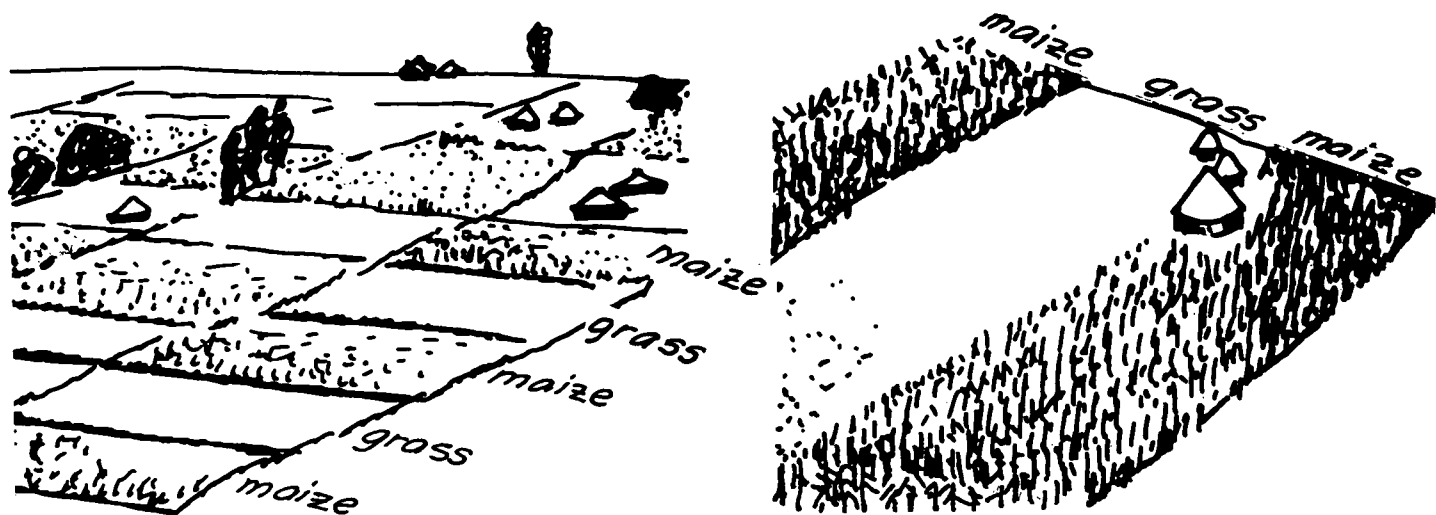

With regard to erosion control the rotational periods should be short. Grass gives 85 % of its erosion resistance during the 1st year and 100 % during the 2nd year. When grass is replaced by maize, erosion will be small during the 1st year, but the residual effect of the grass will be less during the 2nd year. There will be none in the 3rd year. Thus grass is not needed for more than two years.

- 3) Terracing means making channels, ridges, or grass strips to control the flow of water on a slope. Terraces break a long slope into a series of shorter ones, thus reducing the rill erosion. In Kenya bench terraces are recommended, as these also decrease the steepness of the slope, thus reducing both rill erosion and splash erosion.

## 2. Gully erosion

When the erosion has advanced so much that a rill cannot be smoothed out by ordinary tillage, the furrow is not called a rill any more, but a gully.

It is sometimes difficult to differentiate between gullies and valleys created by rivers. Gullies have intermittent water flows of shorter duration than rivers, which have more or less seasonal flows. Gullies, contrary to river valleys, are cut out rapidly, restricted as they are mainly to easily eroded soils. Gullies are short, cutting back up a hillside, but not draining large catchment areas.

### Appearance of gullies

Gullies develop particularly in soils between clay and sand, i.e. loam and silt, because clay is erosion resistant, and because water infiltrates in the sand.

Gullies are often started by insignificant water flows, e.g. along wagon tracks or cattle paths.

### Erosion processes in gullies

At the head of a gully a "waterfall" type of erosion causes a rapid cutting back into the slope (fig. a).

If the earth layer is thick enough, the flow over the floor of the gully will deepen the gully. This deepening does not stop until the gully has reached solid rock (fig. b, showing 3 stages of erosion in the longitudinal direction of the gully).

The deep erosion makes the sides of the gully unstable and causes movement of the soil from the sides of the gully to the bottom. In this way the gully is not only deepened but also widened (fig. c, showing a cross-section of the gully with 3 stages of erosion).

It is not difficult to stop gully erosion in its early stages of development. Unfortunately farmers usually pay little attention to gullies until it is too late, i.e. the gullies have grown so large that they cannot be returned to cultivated land. Small gullies 1-2 feet deep can be filled with trash and soil ploughed over from the sides of the gully. Putting loose brush wood, hay, tree branches, etc into gullies is useless in stopping erosion. Other preventive measures are needed, adapted to the local conditions. One gully is never exactly similar to another.

Gullies occur more on overgrazed grassland in semi-arid areas than in high potential areas, where better vegetation cover protects the soil.

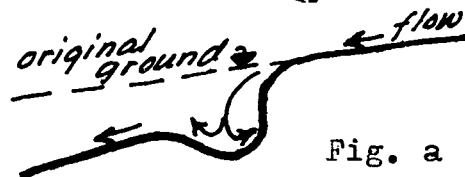
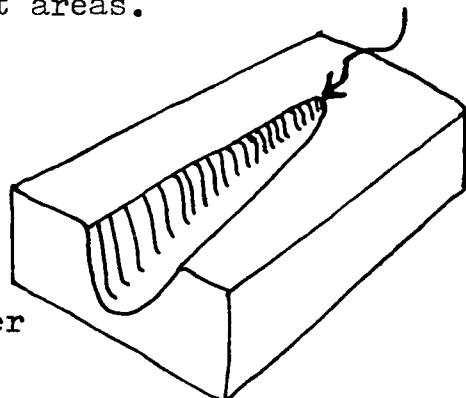

Fig. a

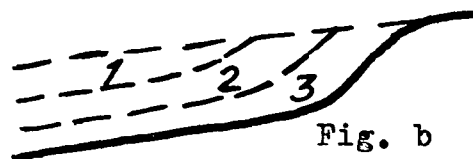

Fig. b

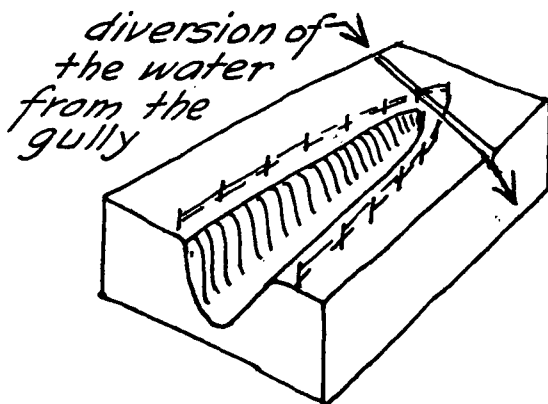

Fig. c

On cultivated land the rills are removed several times a year by ploughing and other operations, but on grassland the rills can grow in size from year to year.

Preventive measures for gully erosion (gully control)

1) Diversion ditch and if possible fencing the gully. If the water flow to a gully is small, and it usually is, the diversion ditch need not be large. Often it is sufficient to construct a small ditch plus a ridge with a plough.



2) Alternatively and especially in small and wide gullies

a) for the head of the gully to prevent the "waterfall erosion":  
piled beds of straw and brushwood or carpet of piled stones  
(if stones are available)

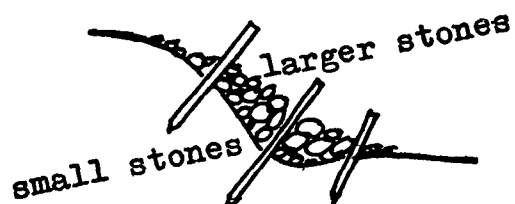
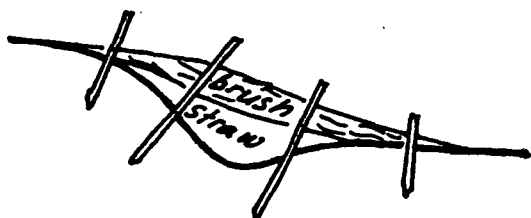

b) for the floor of the gully to prevent deep erosion (check dams creating steps of sediment):  
strips of grass or turves, or stone walls  
in dry areas sisal (if stones are available)

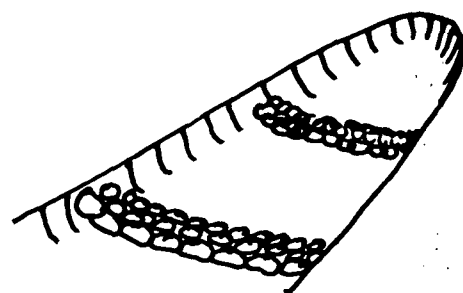
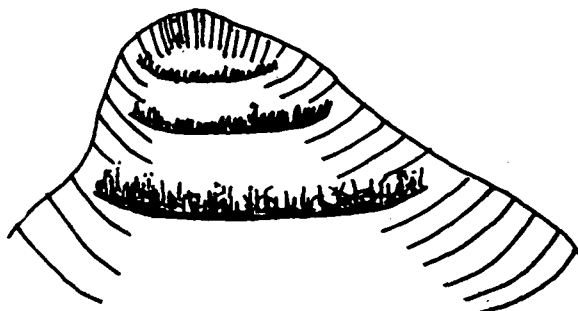

c) for the sides of the gully to prevent widening of the gully:  
trees planted in rows along the contour, but if the slope is less than 1:1  
grass planted as cover e.g. napier or bana grass (in dry areas and in narrow, steep gullies star grass is better)



3) Alternatively, and especially in steep and narrow gullies, check dams have to be more solid to reduce the fall of the slope and to resist the velocity of the water.

The ends of a check dam should be somewhat higher to prevent water from cutting round them.

It is better to construct several low dams than a few high dams.

a) If stones are not available.

A double row of poles 5-6 feet tall should be hammered down across the floor. After that an apron of brushwood should be made as can be seen from the figures on the right. The brushwood used should preferably still have its leaves on. The brushwood should not be laid directly on the ground but on a bed of old grass or weeds.

Between the rows of poles brushwood or branches of trees should be laid across the gully. The brushwood can be fixed with a wire connecting the poles or with large flat stones laid on the surface of the brushwood fill.

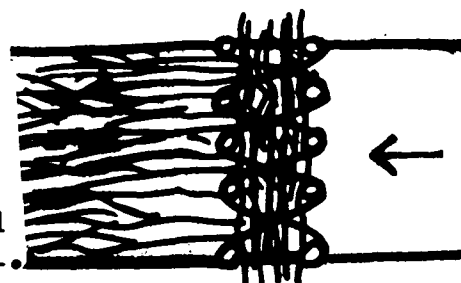
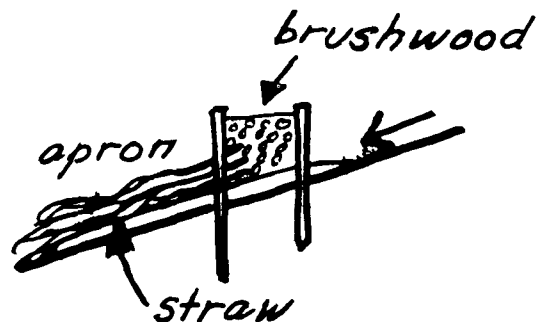

b) If boulders, stones and pebbles are available, check dams can be constructed using these materials (most stones larger than 0.1 m and 1/3 of the stones 0.25 - 0.5 m)

The construction work should start with a shallow excavation, 1/2-1 feet deep, across the floor. In this excavation the largest boulders and stones are laid as a ridge across the floor. Small stones and pebbles should fill up the hollows in the ridge to create stable slopes on both sides of the ridge. Stone check dams should not be higher than 0.5-1 m, in the latter case 1.5 m wide at the bottom and 0.5 m wide at the top.

Below the stone ridge there should be an apron of large flat stones of the same width as the ridge. This apron should also be laid on excavated ground as shown in the figure. Next to the ground and below the large stones, there should be a layer of pebbles and small stones.

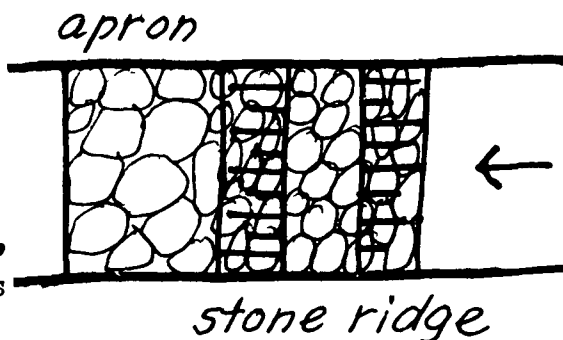
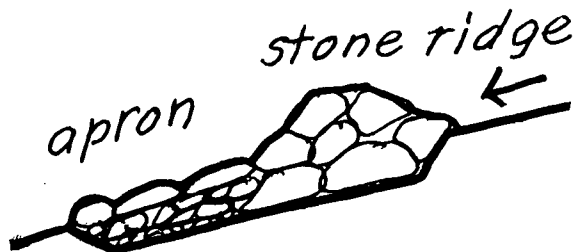



The filled-up dams (steps of silt) are recommended to have small inclination. The difference in height between the crests of successive check dams should be such, that the filled up basins will form level steps, or steps with a slope of a few percent. If the gradient of the gully is not steep and consequently wider spacing is needed it may be difficult to estimate the vertical intervals. Therefore when setting out the sites, horizontal intervals between check dams can be read from the table below:

Table showing spacings in metres between check dams

Gradient %	Height of check dam							
	0.3 m		0.6 m	0.9 m		1.2 m		
2	15		30		45		60	
4	15		30		45		60	
6	7.5		15		23		30	
8	5.2		10.3		15		20	
10	4.0		7.7		11.5		15	
12	3.2		6.3		9.3		12	
14	2.7		5.3		7.8		10	
16	2.3		4.6		a) 6.7 b)7.4	a)8.9	b)10.0	
20	1.8		a)3.7 b)4.5		5.4 6.7	7.1	8.5	
24	1.7		3.1 3.9		4.5 6.1	5.9	8.0	
28	a)1.4 b)1.7		2.7 3.4		3.9 5.4	5.1	6.6	
32	1.2 1.6		2.3 3.2		3.3 4.6	4.3	6.0	
36	1.1 1.5		2.1 3.0		3.0 4.4	3.9	5.7	
40	1.0 1.3		1.9 2.9		2.7 4.2	3.5	5.5	
44	0.9 1.2		1.7 2.8		2.4 4.0	3.1	5.2	

a) wood and gabion constructions b) stone wall with slopes 1:1

Check dam construction should normally start in the lowest part of the gully and proceed upwards.

Examples of various techniques for gully control are given in Appendix 1 (after Chapter XI).

### 3. River erosion

#### The process of river erosion

In watercourses erosion occurs particularly in the bends, where the stream velocity is concentrated against the river bank and where turbulent water causes eddies, lifting particles from the bottom.

Particles of clay and fine silt remain in suspension when transported by the river, whereas the bed load of silt and sand is soon deposited in calm water, decreasing the cross section of the river bed. This cross-section will be too narrow during next flood, and the river will cause new erosion of the river bank. Indeed erosion occurs only during floods, especially during the exceptionally high floods. A few very high floods during a century cause more erosion than all the other minor floods put together during the same century. The conclusion is that the highest water levels of a river are the most dangerous ones, and that the soil in a river valley has to be protected against these extremely high water levels.

A straight channel has its highest velocity (H) in the middle of the cross section:

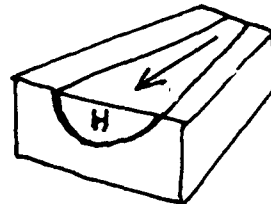

In nature erosion usually appears in the bends, where the stream line of the water comes nearest to the river bank. On the opposite sides of these eroded bends, sand is deposited. Alternating deposits and erosion cause so-called meanders:

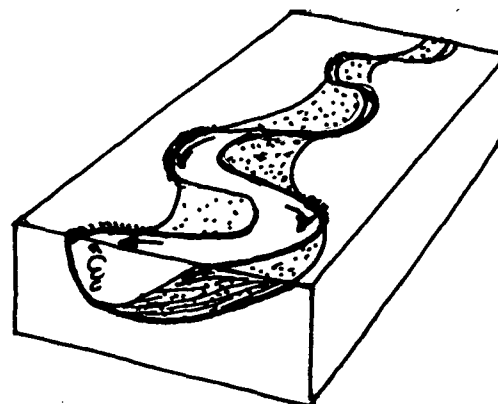

Most of the transported load visible in a river comes from soil erosion in the catchment area. Another part of the load comes from erosion in the river bed and transportation of this material downstream. Only a small part of the transported load originates from erosion of the river banks. In fact the erosion of the river banks is small compared with soil erosion on cultivated and grazed lands on both sides of a river.

#### Preventive measures

Preventive measures for river erosion should be selected with regard to the size of the river and the value of the river bank to be protected.

- 1) As to size there are differences between a) large rivers coming from hills and highlands, b) medium-sized rivers and c) small rivers.

a) Large rivers coming from hills and highlands. -

On most hills and in the highlands the forests have been cut. Thus the rain is not absorbed slowly by the ground but runs off faster than before. This will create higher and shorter floods than before, and less water will infiltrate into the ground. Consequently rivers, which were previously flowing all the year round, have dried up between wet seasons. See the graph below:

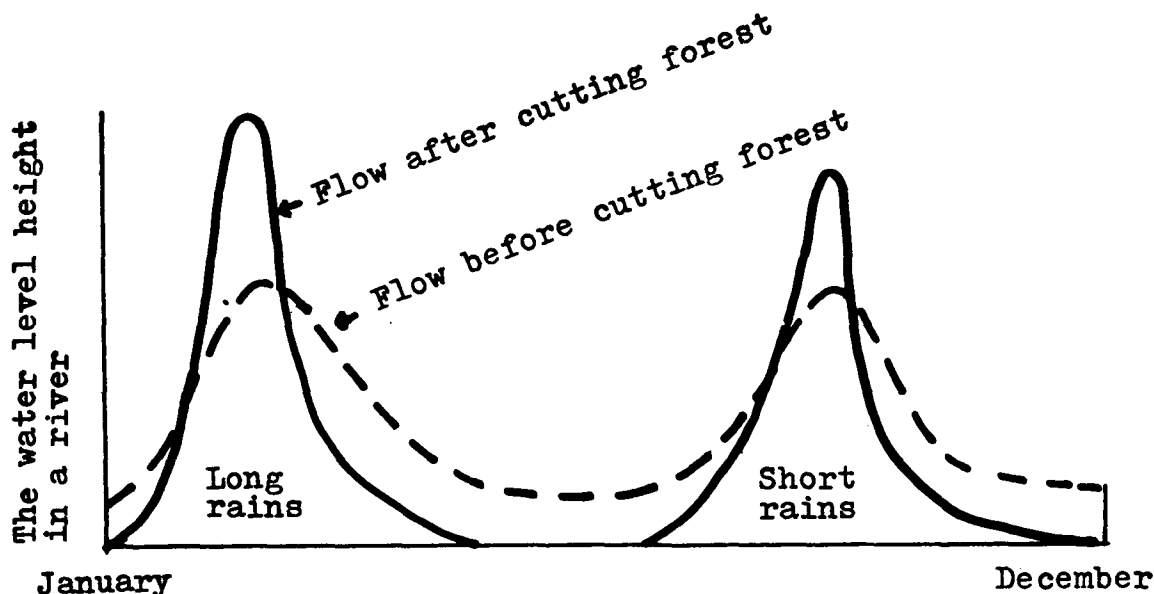

Flood peaks have caused abnormally severe erosion in most of the large rivers of Kenya. The preventive measure in large rivers must be to restore hydrological conditions, i.e. cutting of flood peaks through: 1) reafforestation in the catchment area, 2) construction of water retaining dams and 3) terracing in soil conservation.

b) Medium-sized rivers. -

On the banks of medium-sized rivers the root systems of trees can delay erosion. It should be remembered, however, that river erosion usually starts with excavation of the river bed, followed by the falling down of parts of the bank. Consequently trees can prevent erosion, if the depth of the water is not much deeper than the depth of the roots as shown in the pictures below:

In a deep river the bank is undermined through erosion

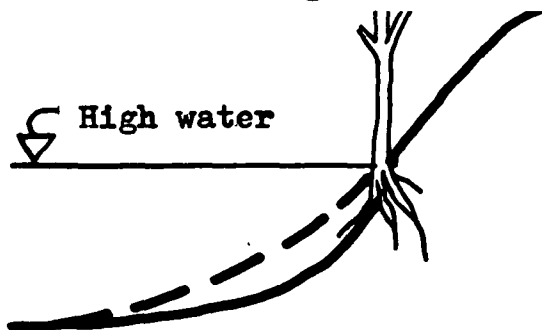

In a shallow river the erosion is delayed thanks to the root system

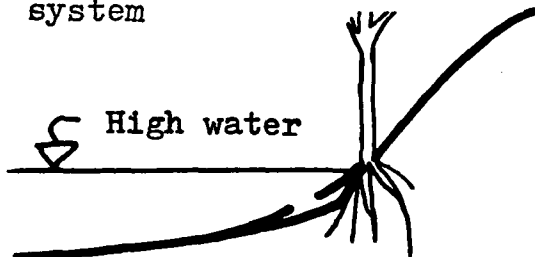

c) Small rivers. -

Along small rivers, about 1 m wide or less, the banks can be protected from erosion by planting grass. A strip of grass 1-2 feet wide on both sides of the watercourse is recommended. See the figure on the right showing a cross-section of a small river with grass strips.

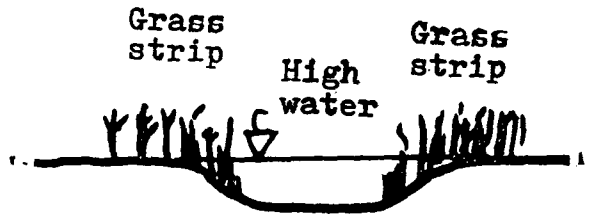

In the bends of medium-sized or small rivers, where erosion is proceeding, it is recommended that a row of poles is put along the bend as shown in the pictures below:

CROSS-SECTION

VIEW FROM ABOVE

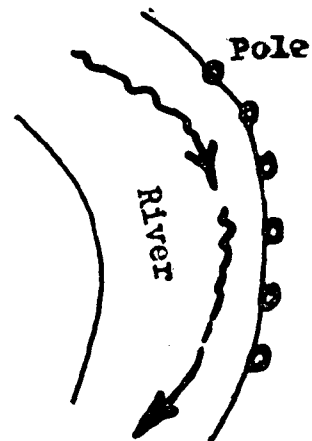
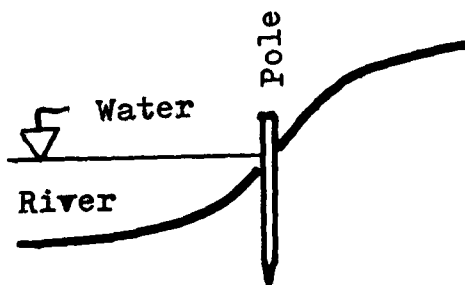

2) To protect valuable ground or buildings at the bends of large or medium-sized rivers there are alternatives depending on large materials available:

a) Stabilization of steep eroded river banks with piles, and brushwood tied up in bundles and loaded with boulders. See the figure on the right.

b) Filling the eroded slope with boulders and stones of sufficient size:

$$d = 2 v^2$$

where d = average diameter of stones in centimetres  
v = mean velocity of flowing water in m/s

Example: If the velocity is as high as 2 m/s, the desired diameter of stones will be  $2 \times 2^2 = 8$  cm.

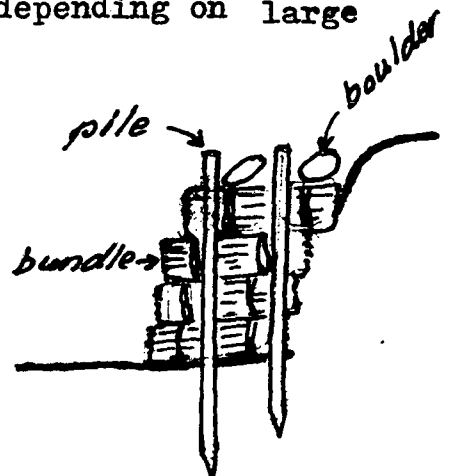

c) If stones are available, but too small to resist the velocity of the stream, then the stones can be put into prefabricated iron wire cages (gabions). See design in Appendix 1 (after Chapter XI).

### 3. SOLIFLUCTION (or earth flow)

#### The process of solifluction

On slopes of loam and silt soils, saturated with water and with ground water pressure, the friction between the particles is decreased, so that the loose wet soil moves slowly downwards with the consistency of jam. There are three types of solifluction:

- 1) shallow solifluction on shamba slopes
- 2) shallow solifluction on pasture slopes
- 3) deep solifluction, often combined with gully erosion.

#### 1) Shallow solifluction on shamba slopes

The superficial particles move more easily and faster downhill (see fig.a).

This is evident from the bent stalks of plants. The solifluction makes the plant lean downhill (fig.b).

But the phototropism of the plant causes the growth to be straight. The result will be a bent stalk as evidence of strong solifluction (fig.c).

Preventive measures for type 1 are:

- 1) Terracing
- 2) Drainage of the ground water flow.

#### 2) Shallow solifluction on pasture slopes

In this case strips of grass turves along the contour move downhill. This type of solifluction is visible on steep pasture slopes in areas with high rainfall. The movement of the grass turves can be accentuated by cattle using the turves as paths. Prerequisites for this type of erosion are: a) slopes exceeding 60-90% and b) a discharge area large enough to create a ground water flow.

#### 3) Deep solifluction

The reason for this type of erosion is the cutting down of forest trees, which thus do not absorb water any longer. If the surplus water is discharged not only along the ground as overland flow, but also as a ground water flow down the slope, and if the soil is loam or silt, the slope will not be stable any more. The water pressure will create backward erosion on a broad front.

Preventive measures for types 2 and 3 are:

- 1) If the erosion is not too advanced, drainage of the slope through diverting the water.
- 2) Reafforestation or at least some rows of trees (e.g. four rows of Eucalyptus) above the solifluction area.

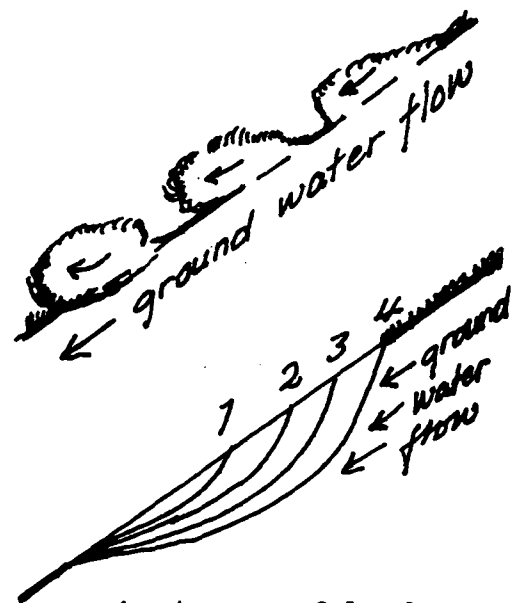
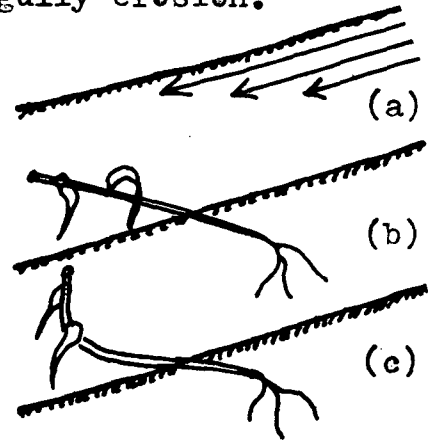

4 stages of backward erosion. The height of the scar can be from less than 1 m to more than 10 m.

#### 4. SLIDES

##### The process of slides

A slide is a rotational movement of a mass of soil along a more or less semi-circular slip surface (fig. a).

The result of this process is also called a slide (fig. b).

Such an unstable slope can be regarded as a balance with pushing of the upper part downwards, and the earth mass of the lower part resisting. Movement or not depends on the shear strength of the earth, usually clay or loam (fig. c). Such a mass movement of earth happens rather suddenly contrary to the slow solifluction movement (p. 14).

The start of a slide can be caused by a decrease of the resisting earth mass, e.g. through erosion of a river bank. This usually happens in the bends of a river (fig. d).

In cohesive soils of clay or loam stable slopes can become unstable through increased water pressure in the earth of the slope, which decreases the shear strength of the earth and causes a slide. This type of slide can be seen on steep pasture slopes (usually exceeding 40-60 % = approx. 20-30°) where ground water pressure builds up because the forest has been removed (fig. e).

fig. a

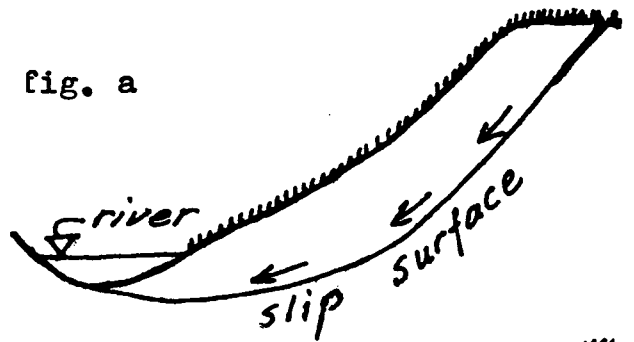

fig. b



fig. c

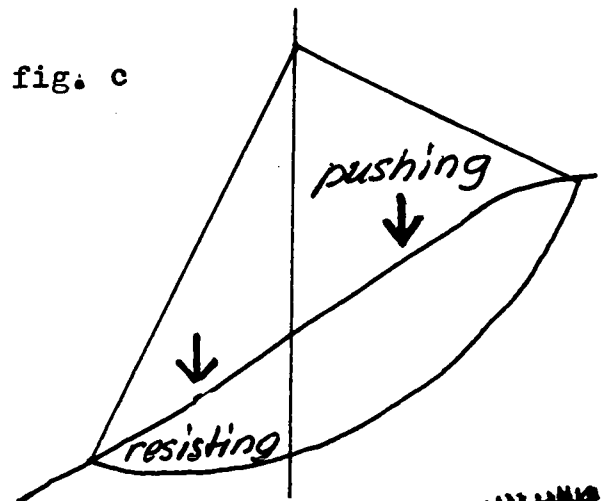

fig. d

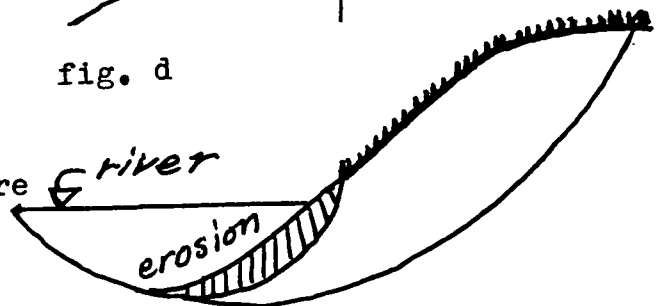
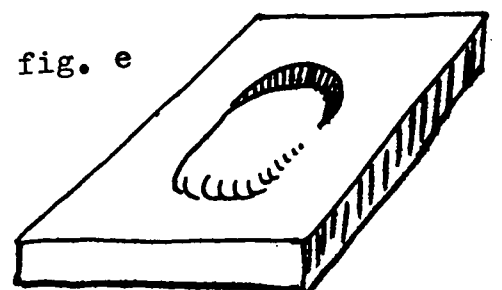

fig. e



A small slide, "slumping", on a slope:

Preventive measures

Preventive measures depend on the conditions, which are assumed to cause the slide.

1) On pasture slopes reforestation, or at least patches of forest, because tree roots absorb water better than grass roots thus decreasing the water pressure (fig. f).

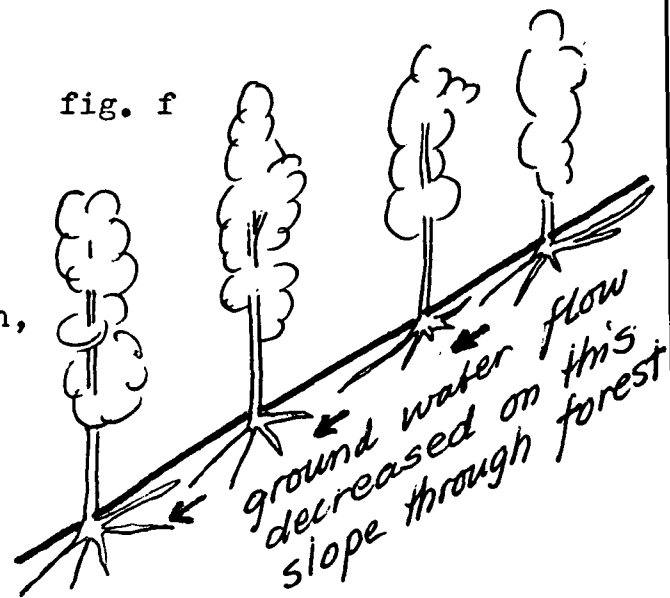

2) On steep river banks preventive measures as against river erosion (p. 12).

3) In individual cases a slide movement with the pressing up of earth (fig. b) can be prevented through the application of a counter pressure in the form of an earth bank (fig. g).

fig. g

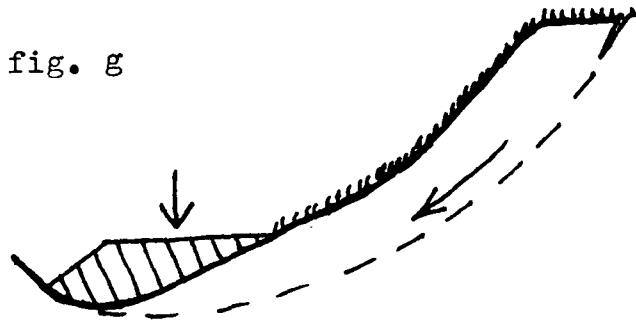

Example

A slide occurred at Wanjerele village, Kangema Division, Murang'a District on 12th April, 1978. Houses were damaged, and 2 children, 17 goats and 1 cow were killed by the earth which had slid. The place is situated in the tea zone 2,300 m above sea-level. Before the slide there was a slope of 55 % (=approx. 30°) used for grazing, which slid in three stages. There had been a fissure along the road for a long time, and after intense rainfall the fissure was widened, and part of the slope 40 m wide fell down and moved about 200 m onto the flat land below the slope (1st stage in the figure). After that a second slide occurred. In this case the earth mass just sunk down, forming a wide terrace. Finally the slope above the first slide (and above the road) slipped.

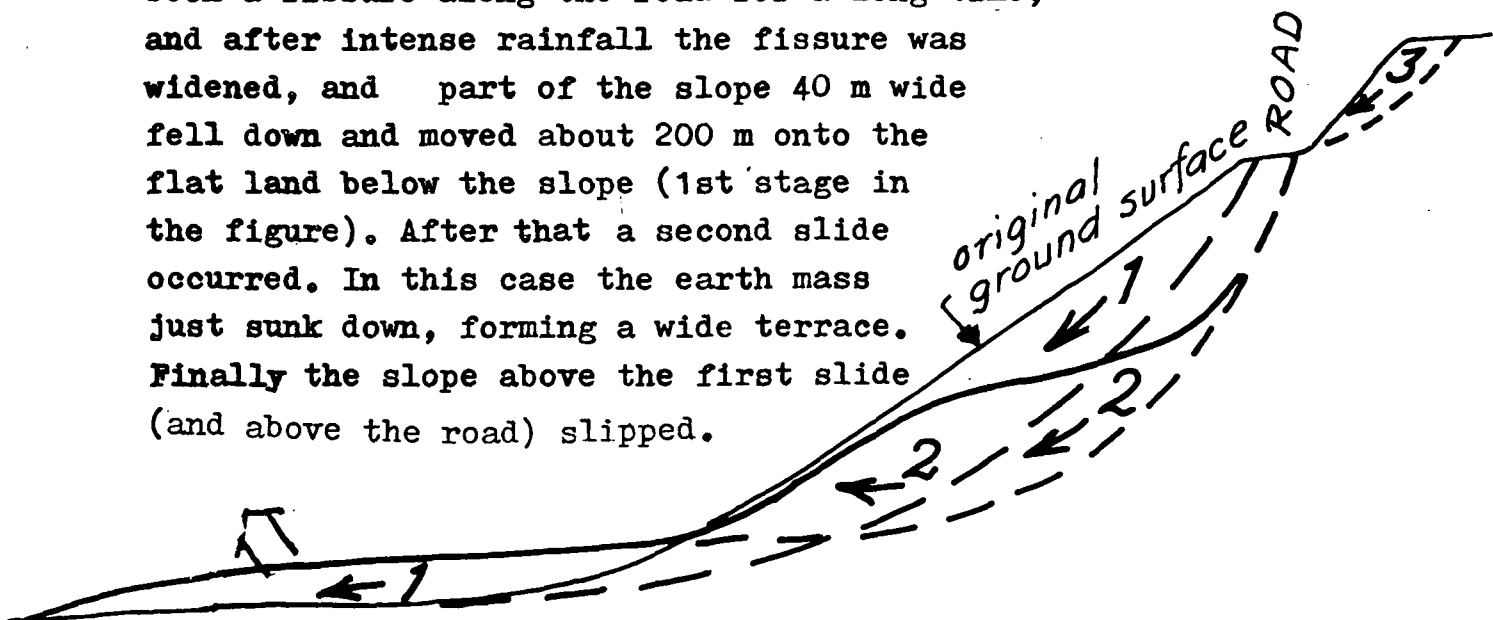

## 5. WIND EROSION

### The process of wind erosion

There are two main types of erosion causing transportation by wind:

- 1) particles of sand moved more or less along the ground (wind drift)
- 2) fine particles lifted up into the air (suspended material).

#### 1) Wind drift of sand

Wind drift of sand usually occurs in arid climatic zones and on sandy beaches. It can be stopped by planting suitable plants and trees or by constructing sand catching walls.

#### 2) Usual wind erosion

Soil particles are detached from the ground by wind, when:

- a) the soil is bare (it is not protected) and dry (no cohesion)
- b) soil particles are of sand, silt or loam grade (i.e. loamy fine sand); the sand is liable to blow away, if more than 60% of unaggregated grains have a diameter of 0.1-0.5 mm, but not liable to blow, if less than 40% have a diameter of 0.1-0.5 mm.
- c) the velocity of the wind is high enough (limit for erosion about 13 miles per hour at 1 ft above the ground, i.e. 6 m/s). Such a velocity can be described as capable of moving small but not large branches of trees, and capable of stretching a flag). Of course strong winds and eddies of strong winds are more erosive than more gentle ones.

Wind erosion can be disastrous, if the topsoil is removed. This can happen not only in arid and semi-arid areas, but also on cultivated land in high potential areas during parts of the year, when there is no rain and if there is no crop cover or any other protection.

### Preventive measures

Preventive measures against wind erosion are:

- 1) stubble mulch tillage
- 2) wind strip cropping
- 3) windbreaks and shelterbelts.

#### 1) Stubble mulch tillage

Crop residues are left on a rough tilled soil surface.

The crop residue and the rough surface reduce the wind velocity and trap the soil particles moved by wind.



2) Wind strip cropping

Wind strip cropping, used against wind erosion on large plains in dry areas, does not follow the contour of the land and is of little value in conserving water. The long, straight and parallel strips are placed across the prevailing wind (compare the two figures below).

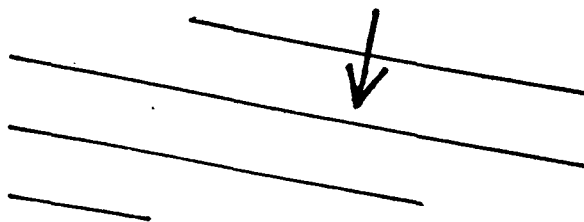

Field strip cropping against wind erosion

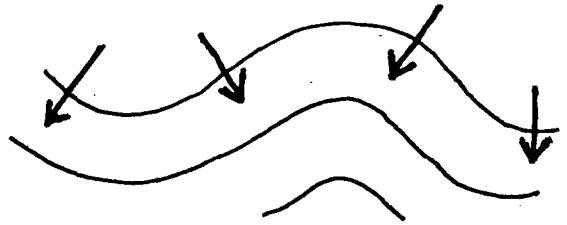

Contour strip cropping against water erosion

As the strips have vegetation of different kinds at different development stages, some strips of vegetation will always decrease the velocity of the wind and limit the erosion. The table below shows the average widths of strips needed on erodible soils:

Soil	Widths of strips in feet for various wind direction angles from strips		
	90°	70-110°	45-135°
sand (and silt)	20	18	14
loamy sand	25	22	18
sand loam	100	92	70
silt loam	280	260	190
loam	250	235	170
clay loam	350	325	290

3) Windbreaks and shelterbelts

A windbreak is usually a row of trees (with a spacing of 1.5-3 m) perpendicular to the prevailing direction of strong winds. The area protected is not only on the leeward side (at least 10 times the height of the windbreak) but also on the windward-side (up to 5 times). See the figure below:

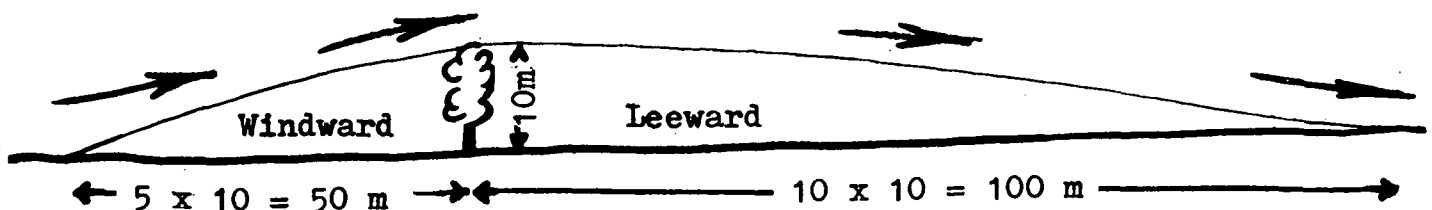

At the ends of a windbreak the velocity is increased (to 110-120 %). This shows that windbreaks should be long and continuous without

gaps. On the other hand a windbreak should not be a dense wall, because this will create an eddying effect, and a reduction of the area protected on the leeward side.

The distance between two windbreaks should be 20 times the height of the windbreak. A suitable tree species with a well developed canopy from the top to the ground is *Conocarpus lancifolius*. Some *Eucalyptus* species are also suitable. Often there is space for only one row of trees as a windbreak. However, the windbreak can be more efficient, if smaller trees and/or bushes are planted on the windward side, or on both sides at a spacing of 3-4 m (see the figure below).

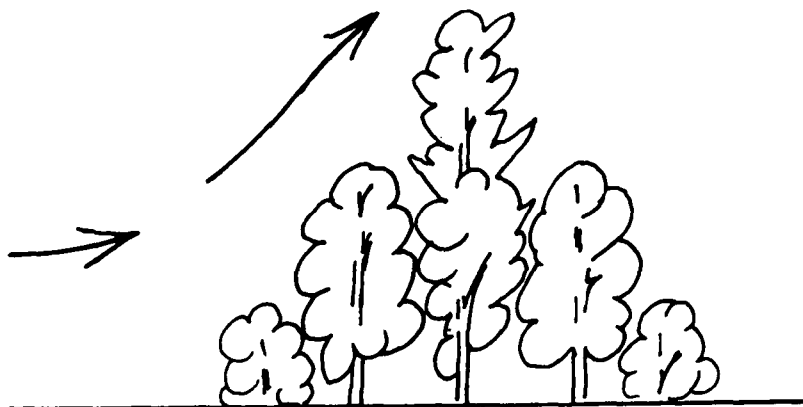

A very good shelterbelt, needing land 56 feet wide, can be made in the following way (Wimbush 1942):

- a) 2 rows of a hedge, planted 2 feet apart, then a space of 10 feet
- b) 2 rows of medium-tall trees, 10 feet apart, then a space of 15-20 feet
- c) 2 rows of tall trees, 12 feet apart. Examples of medium-tall trees for areas with different annual rainfalls:

more than 1,000 mm	Cupressus macrocarpa (monterey cypress)
1,000-875 mm	" torulosa (Himalaya cypress)
875-750 mm	" arizonica (Arizona cypress)
less than 750 mm	Grevillea robusta (silky oak)
	Casuarina cunninghamiana (river oak)
	Schinus molle (pepper tree)
	Callitris robusta (cypress pine)

Roads etc. through a shelterbelt should pass diagonally to prevent wind funnelling through the openings.

A good shelterbelt decreases the evaporation and can increase yields by 10-20 %, and during years of drought by 50-60 %.

II PREDICTION OF SOIL LOSS  
AND  
CHOICE OF SOIL CONSERVATION MEASURES

C O N T E N T S

	pages
1. The soil loss equation	21 - 30 a
2. How the equation can be used	31 - 34
3. Questions	34

### SOIL LOSS EQUATION

As has been mentioned in the previous chapter on "Erosion Processes and their Preventive Measures" various conditions influence the soil loss through erosion. These conditions are illustrated below:

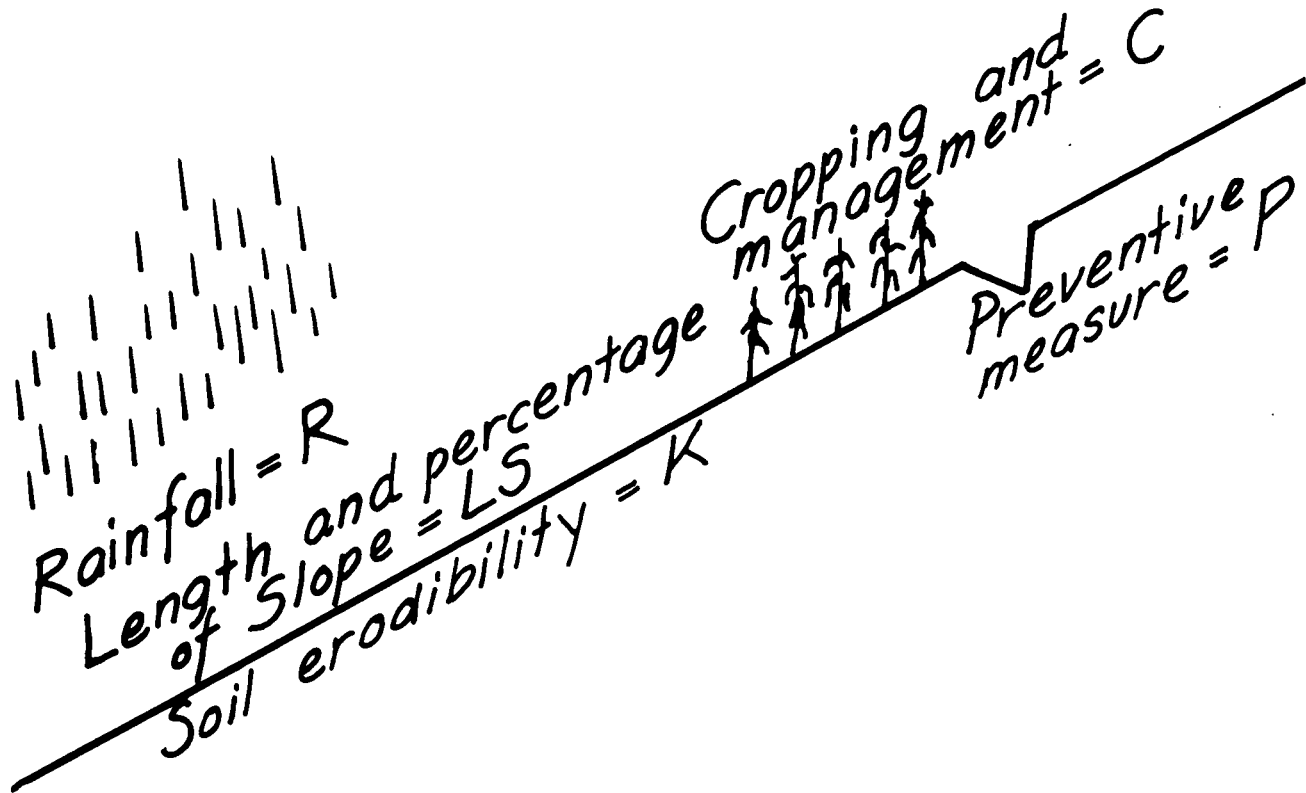

The most important factor is the rainfall. It was discovered by Wischmeier in the U.S.A., that the soil loss from erosion cannot be correlated only to the amount of rainfall, but it must also be related to the intensity of the rain. Wischmeier also found that the soil loss through splash and rill erosion can be calculated using the factors illustrated above in an equation:

Annual soil loss                  Natural physical conditions                  Human influence

$$A = R \times K \times L \times S \times C \times P$$

The different factors of the "soil loss equation" will be explained in more detail in the following pages.

$A = \text{Annual soil loss in tons/acre}$  (1 American "short" ton = 0.907 metric tons; 1 ton/acre corresponds to 2.5 metric tons/hectare, i.e.  $1 \text{ ton/acre} = \frac{\text{tons/ha}}{2.5}$  ).

In nature the formation of the topsoil is a slow process, taking at least 300 years for the topsoil to increase by 1 inch (25 mm). On cultivated land the process is faster. The increase in topsoil is about 1 inch in 30 years on a subsoil of deep loam. This rate corresponds to an annual addition of topsoil of 5 tons/acre. A soil loss through erosion must not exceed this figure to be acceptable. However, the annual soil loss depends on the thickness of the soil and the erodibility of the soil. Thus the acceptable mean annual soil loss is:

- 1) On shallow soils 1-3 tons/acre, often 2 tons/acre
- 2) On deep soils of sand and silt 4 tons/acre
- 3) On deep soils of loam and clay 5-7 tons/acre, often 5 tons/acre.

These figures are averages for a certain number of rotations of crops and grass. During years of maize crops the acceptable loss might run up to about 10 tons/acre (1 ton/acre = 2.5 metric tons/hectare).

$R = \text{Rainfall factor}$  which shows the capability of a rainstorm to erode the soil on fallow land, i.e. bare soil without any protection. It is proportional to the maximum Intensity of rain during a period of 30 minutes (I) and the Energy of the rain (E). The formula is  $R = E \times I$ . I can be measured and E can be estimated as there is a good correlation between rain intensity and Energy.

I-values, expressed in inches per hour, are computed from rain gauge charts. The chart below shows how to obtain the greatest 30-minute intensity during a rainfall. This amount of rain has to be doubled to obtain the intensity per hour in the graph and the table on the next page.

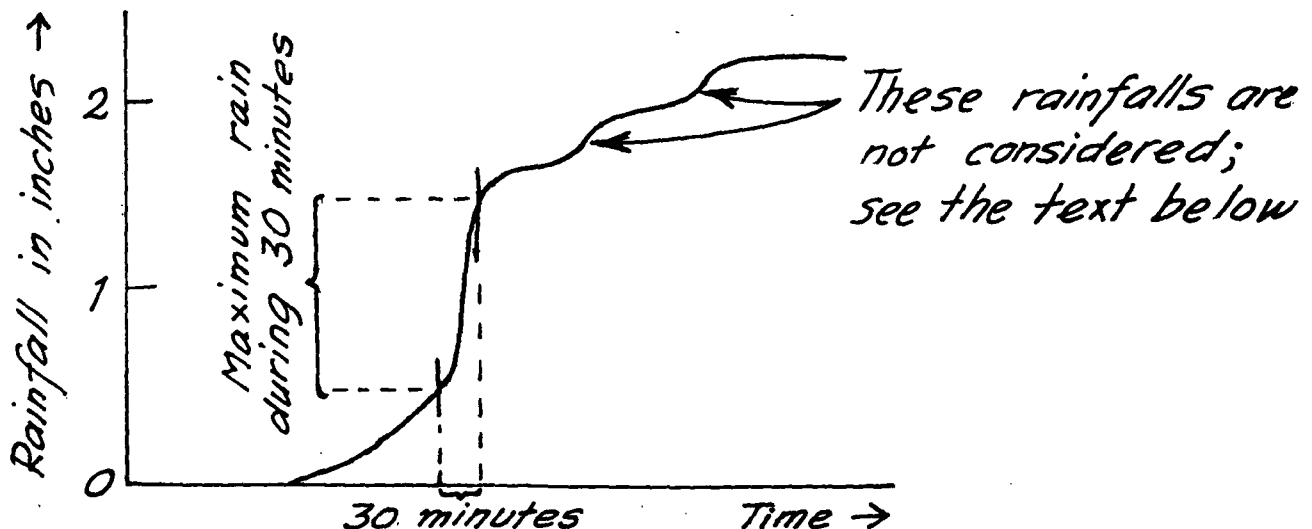

Only maxima greater than 1/2 inch (12.5 mm) should be considered, and between two maxima considered, there should be at least 6 hours with less than 0.05 inches of rainfall (1.3 mm).

E-values per inch of rain, expressed in foot-tons per acre and divided by 100 to make the figures more manageable, can be read from the graph (see below) or more accurately from the table (see further down).

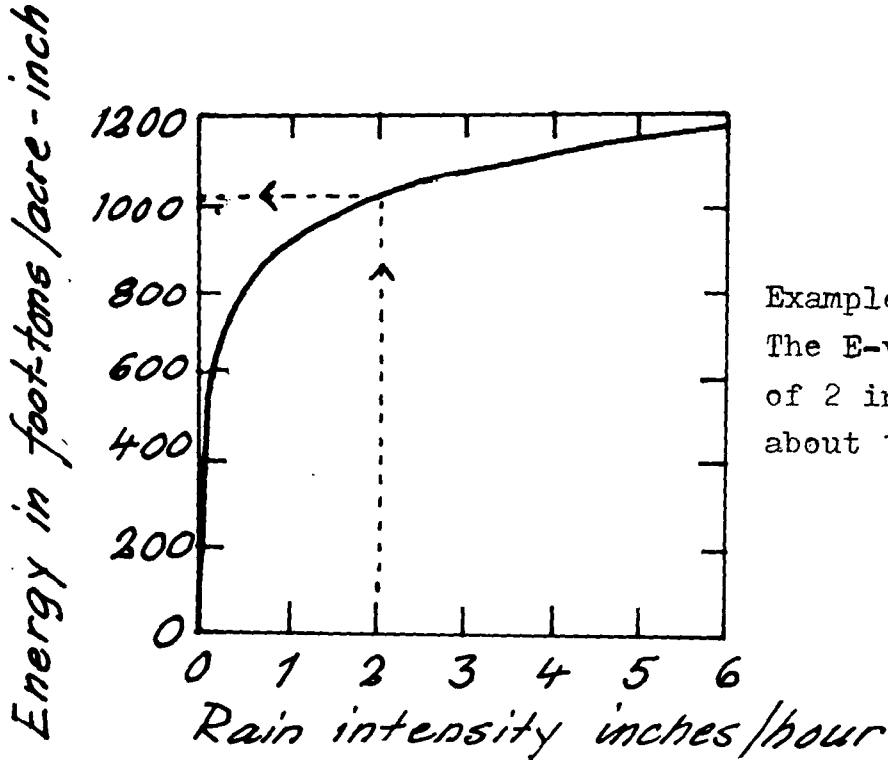

Example:  
The E-value for an Intensity of 2 inches of rain is about 1,000.

KINETIC ENERGY OF NATURAL RAINFALL<sup>1</sup>

Intensity inches/h	0.00	0.01	0.02	0.03	0.04	0.05	0.06	0.07	0.08	0.09
	..... Foot-tons/acre-inch .....									
0	0	254	354	412	453	485	512	534	553	570
0.1	585	599	611	623	633	643	653	661	669	677
0.2	685	692	698	705	711	717	722	728	733	738
0.3	743	748	752	757	761	765	769	773	777	781
0.4	784	788	791	795	798	801	804	807	810	814
0.5	816	819	822	825	827	830	833	835	838	840
0.6	843	845	847	850	852	854	856	858	861	863
0.7	865	867	869	871	873	875	877	878	880	882
0.8	884	886	887	889	891	893	894	896	898	899
0.9	901	902	904	906	907	909	910	912	913	915
	0	0.1	0.2	0.3	0.4	0.5	0.6	0.7	0.8	0.9
1	916	930	942	954	964	974	984	992	1 000	1 008
2	1 016	1 023	1 029	1 036	1 042	1 048	1 053	1 059	1 064	1 069
3	1 074	1 079	1 083	1 088	1 092	1 096	1 100	1 104	1 108	1 112
4	1 115	1 119	1 122	1 126	1 129	1 132	1 135	1 138	1 141	1 144
5	1 147	1 150	1 153	1 156	1 158	1 161	1 164	1 166	1 169	1 171
6	1 174	1 176	1 178	1 181	1 183	1 185	1 187	1 189	1 192	1 194
7	1 196	1 198	1 200	1 202	1 204	1 206	1 208	1 209	1 211	1 213
8	1 215	1 217	1 218	1 220	1 222	1 224	1 225	1 227	1 229	1 230
9	1 232	1 233	1 235	1 237	1 238	1 240	1 241	1 243	1 244	1 246

Example:  
The E-value for an Intensity of 2 inches of rain is 1,016.

<sup>1</sup> Conversion to joules per centimeter of rainfall on 1 square meter can be made by multiplying foot-tons per acre by 0.2635.  
Inches of rainfall multiplied by 2.54 = centimeters of rainfall.

EI-values for all storms during a year have to be added together to get the erosivity<sup>(1)</sup> or the "Rainfall erosion index",  $R = \sum E \times I$ .

Using available records I have calculated some EI-values for Kenya:

Place	Average rainfall erosion index	Period for calculation of the average
Eldoret	223	1959 - 67
Kisumu	522	1960 - 72
Kitale	325	1960 - 72
Lodwar	65	1960 - 72
Malindi	207	1960 - 71
Mombasa	171	1960 - 72
Nairobi	212	1960 - 72
Nakuru	129	1958 - 71
Nanyuki	121	1963 - 72
Narok	154	1962 - 72
Voi	(163)	1960 - 68, 71 - 72

These figures are too limited to make a map of the rainfall erosion index for the whole of Kenya. Provisionally we might distinguish the following index areas for places not mentioned in the table above:

- 1)  $R = 500$  in the area close to Lake Victoria including Nyanza and Western Provinces. It is typical of a tropical area that the rainfall is higher and more intensive than in subtropical and temperate zones. This is because more and bigger raindrops fall per unit of time.
- 2)  $R = 300$  in the Highlands west of the Rift Valley including Trans Nzoia, Uasin Gishu, Nandi and Kericho Districts.
- 3)  $R = 200$  in southeastern Kenya down to the Indian Ocean. Most of it is subtropical with less intensive rain. The mountain areas with higher rainfall are not supposed to have much greater figures as such rains usually have small rain drops. The Coastland is indeed tropical, but the rainfall is less than close to Lake Victoria.
- 4)  $R = 50$  in the northeastern and driest part of Kenya.

Along the boundary between two index areas an average figure of the two areas might be used.

---

1) Erosion is a function of the erosivity (of the rain) and the erodibility (of the soil).

K = Soil-erodibility factor for soil losses on clean-tilled and continuous fallow, expressed in tons/acre (as per rainfall erosion index unit for a standard plot of 72.6 feet long and with a 9 % slope).

The various types of soils have different degrees of erodibility, but unfortunately this can only be correlated to measurable properties to a limited degree. From measurements of erodibility and rainfall mainly in the U.S.A., we might select the following values for the K factor:

<u>sand</u> and loamy sand	<u>0.1</u> (low because of high infiltration)
sandy loam and silt loam	0.25
<u>loam</u>	<u>0.4</u> (high because of low infiltration and weak cohesion)
clay loam	0.3
<u>clay</u>	<u>0.2</u> (low because of strong cohesion)

The values might be lower, if the soil particles were bound e.g. by iron oxides ("murrum"). Gravel and stones on the ground can reduce the K-factor by half, if the cover of stones is at least 10 - 20 %.

LS = Length-Slope factor, also called the Topographic factor.

L, expressed as length in feet of a water flow down a slope and S, expressed as a percentage of the steepness of the slope, might be calculated separately:

$$L = \frac{f}{72.6}^{0.5}$$

where f is the length of flow (slope) in feet and 72.6 feet the length of the standard plot; the exponent varies between 0.3 (slope less than 0.5 %) and 0.6 (slope more than 10 %) average value = 0.5.

$$S = \frac{(0.43 + 0.30 \times s + 0.043 \times s^2)}{6.613}$$

where s is % slope (in a parabolic equation mathematically describing the relationship soil loss and slope).

LS, computed from the two equations above, can be more easily read from the chart on the next page, using slope in % and slope length in feet, or from the chart on page 26, using slope in % and slope length in metres.



Example:  
 The LS-factor for a 300  
 foot slope of 14 % is 4.  
 For the standard plot,  
 72.6 feet long and  
 slope 9 %, LS is 1.

LS - factor

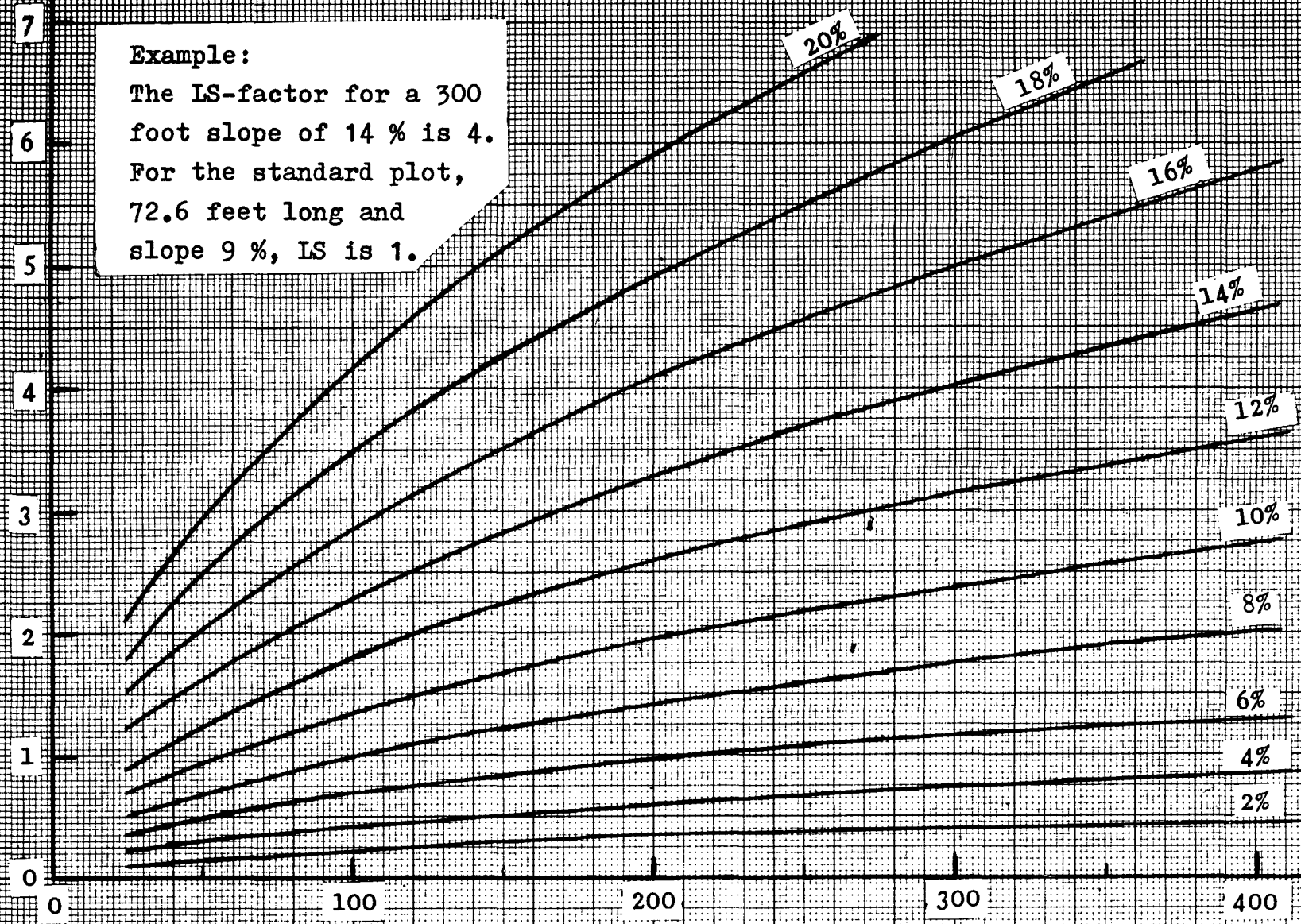

Slope length, feet

If there are ditches or terraces across a slope, the slope length should be the horizontal distance between such structures.

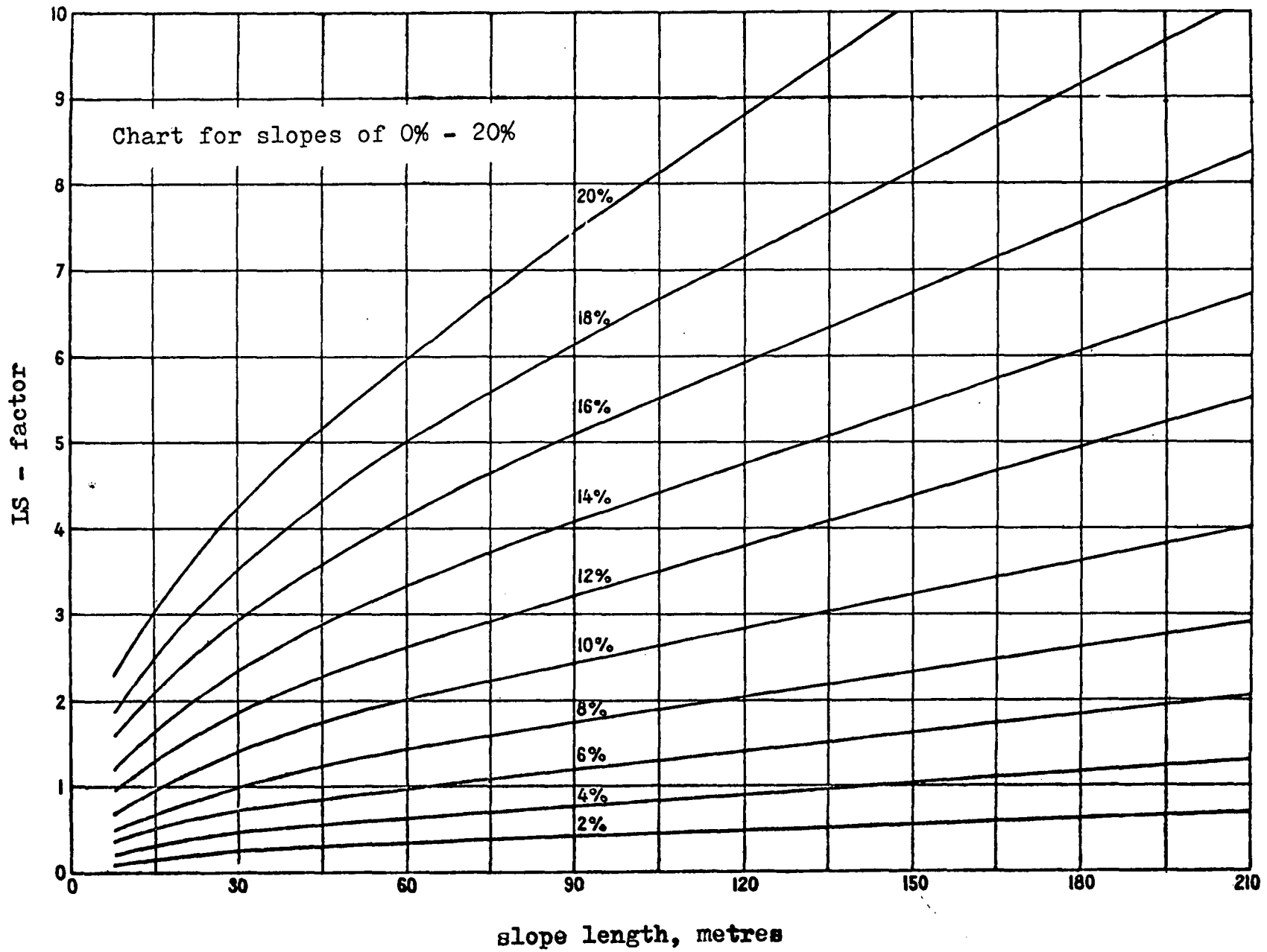

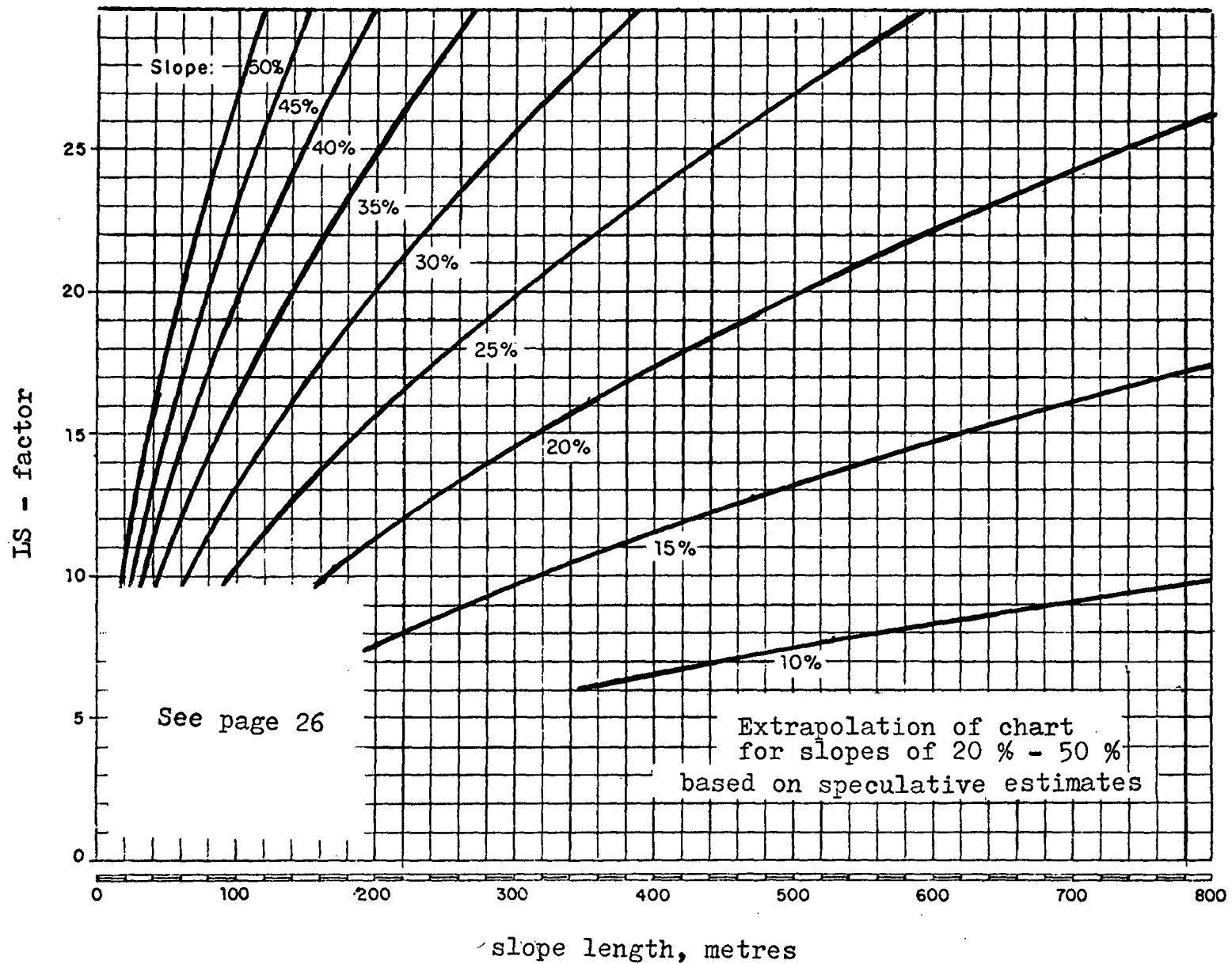

C = Cropping and management factor, considers the soil loss under specific cropping and management compared with the loss from a continuous fallow, as well as the influence of rainfall during the different crop stages.

The calculation of C is rather complicated. The protective effect of the crop and its management varies during a year, as also does the erosivity. Therefore the factor of C is determined for five crop-stage periods:

- 0) Fallow or preparation of seedbed
- 1) Seedbed = 1st month after seeding
- 2) Establishment = 2nd month after seeding
- 3) Growing cover = 3rd month from seeding to harvest
- 4) Stubble = from harvest to ploughing.

The soil loss of a specific crop-stage period expressed as a percentage of the soil loss from a continuous fallow is called the soil loss ratio. In the U.S.A. the soil loss during the five periods has been measured in many combinations of cover, crop residue, productivity, growing season, tillage practice and residue management. For Kenya such data is not available, but on the next page there are 100 different combinations from the U.S.A.

The rainfall also varies during the same five periods. The graph below shows the monthly cumulative percentages of annual erosivity, or expressed in another way, the monthly distribution of the annual rainfall erosion index. From such a graph the percentage of the EI-value for each of the five periods can be obtained:

The erosivity (EI-value) for each period is the difference between the percentages at the beginning and at the end of the period, e.g. 11% at the beginning and 20% at the end gives 9% for use in the calculation of C (see page 29).

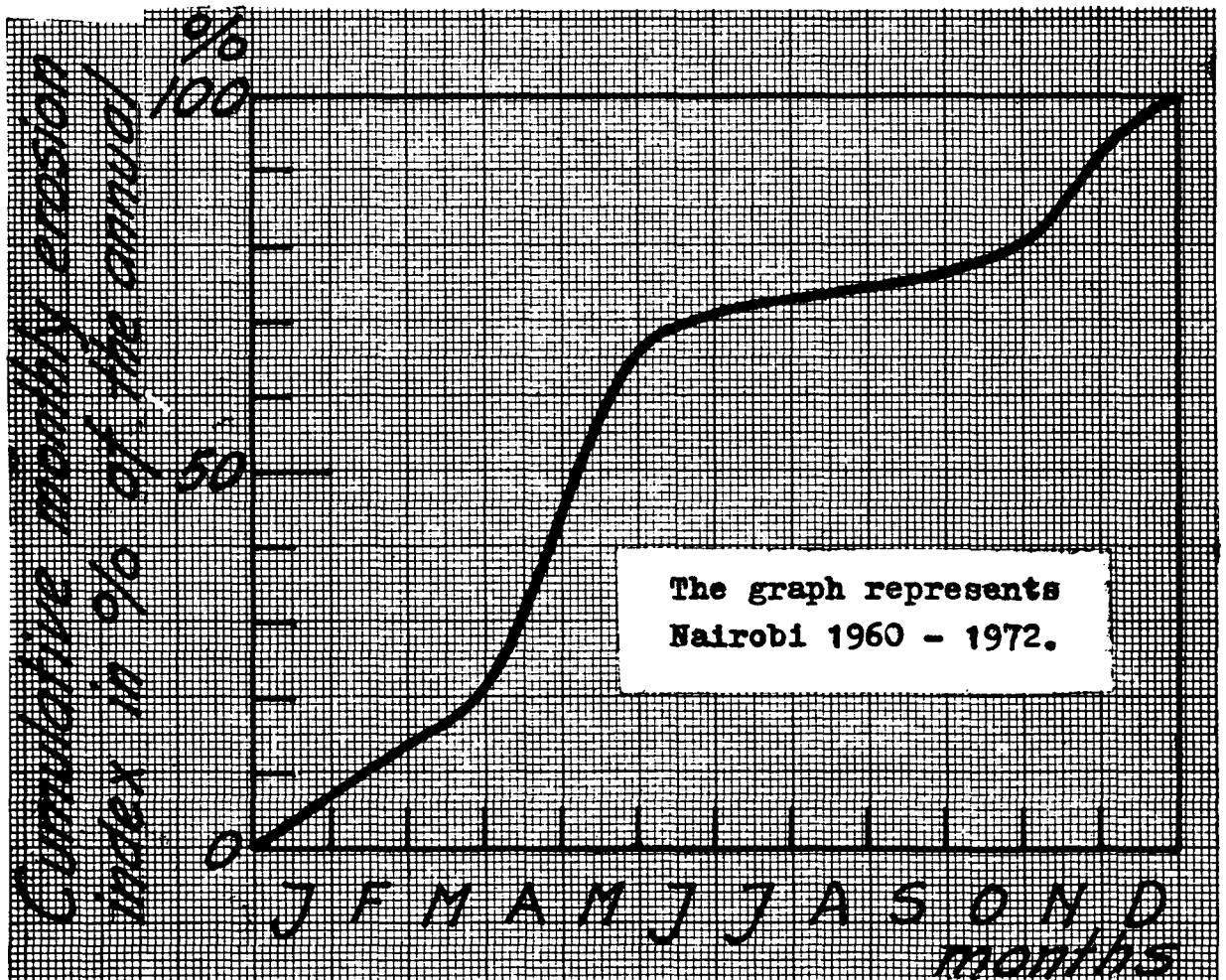



Here are two examples of how to calculate the C-factor: No. 1 from Kenya, No. 2 from the U.S.A.

Example 1. - The place is supposed to be near Nairobi with a continuous cultivation of maize. Crop residues are removed. There is no application of manure or fertilizer. The yield of maize is 7 bags per acre. The calculations for this example are shown in the table below. The crop-stage periods in column 3 are those specified on p. 27. The soil loss ratios in column 4 have been taken from the table on p. 28, line 1. The rainfall erosion indices in column 5 have been read from the graph on p. 27. The value of the C-factor in column 6 is the product of columns 4 and 5, i.e. the product of the Soil Loss Ratio and the Rainfall Erosion Index.

1	2	3	4	5	6
Crop	Crop stage period, number	Dates of beginning and end of periods	Soil loss ratio per period, percentage	Percentage of annual Rainfall erosion index per period	Value of C-factor
Maize	1	15/3-15/4	92	14	0.13
	2	15/4-15/5	80	27	0.22
	3	15/5-1/8	50	17	0.09
	4	1/8-1/9	85	2	0.02
	0	1/9-1/11	85	5	0.04
	1	1/11-1/12	92	13	0.12
	2	1/12-1/1	80	8	0.06
	3	1/1-1/3	50	12	0.06
	4	1/3-15/3	85	2	0.02
	Totals		12 months		100

Usually the farmers have maize intercropped with beans, which reduces the erosion, at least during the third month after seeding, thereby reducing the value of the C-factor by at least 0.06 to C = 0.7.

Example 2. - In the table on the next page, which contains data from the U.S.A., there is a 4-year rotation of: 1) grass, 2) maize, 3) maize and 4) oats. Yields of meadow grass are 2 tons/acre and of maize 12 bags/acre. Residues are left on the shamba. The soil loss ratios for the different periods are given in column 4, and the percentages of the annual rainfall erosion index during the different periods, in column 5. The value of the C-factor in column 6 is the product of columns 4 and 5, i.e. the Soil Loss Ratio and the Rainfall Erosion Index.

Crop	Crop stage period, number	Dates of beginning of periods	Soil loss ratio per period, percentage	Percentage of annual Rainfall erosion index per period	Value of C-factor	
					per period	total
Grass (meadow)		1/8				
		1/3	0.6	49	0.003	
		1/3	0.6	100	0.006	0.01
Maize	1	1/4	15	9	0.0135	
	2	1/5	32	11	0.035	
	3	1/6	30	11	0.033	
	4	1/10	19	35	0.0665	
	5	1/3	30	34	0.112	0.25
Maize	1	1/4	42	9	0.038	
	2	1/5	57	11	0.063	
	3	1/6	49	11	0.054	
	4	1/10	28	35	0.098	0.25
Oats	1	1/11	58	6	0.035	
		1/4	35	37	0.13	
		1/6	15	22	0.033	0.20
		1/8	3	20	0.006	0.01
Total for 4 years				400		0.72
Annual average				100		0.18
				rounded to <u>C = 0.2</u>		

This value is much lower than that for normal Kenya conditions, C = 0.7 (p.29).

With regard to plants other than maize there are the following C-values available from West Africa, based on 20 years of measurements:

Sorghum, millet 0.3 - 0.9 (average 0.6)

Groundnuts 0.4 - 0.8 (average 0.6)

Cassava (1st year) 0.2 - 0.8 (average 0.5)

Cotton, tobacco 0.5

Cover crops

late planted or with slow development (1st year) 0.3 - 0.8  
(2nd year) 0.1

Cover crops with trees as coffee and palms 0.1 - 0.3

For forest and savannah you might use a C-value of 0.01 .

There are more detailed figures for forest as well as for pasture, rangeland and idle land (Arnoldus 1976).

P = Practice factor for conservation, where ploughing up-and-down hill is considered to be = 1.0. In the table below the P-values can be read for % of slope and kind of soil conservation measure used:

% slope	contour farming	contour farming + strip cropping + rotation of crops	contour farming + terracing
2 - 6	0.5	0.25	0.1
7 - 11	0.6	0.3	0.12
12 - 17	0.8	0.4	0.16
18 - 23	0.9	0.45	0.18
24 - 55	1.0	0.5	no value available

As can be seen from the table, contour farming on slopes of 2-6 % can reduce the soil loss by 50 % compared with cultivating up-and-down hill. Combined with strip cropping the soil loss will be reduced by a further 50 % (factor reduced from 0.5 to 0.25). If contour farming and strip cropping are not sufficient, terracing remains as another Practice factor. Terracing includes channels, grass strips and wide vegetative strips (buffer strip cropping).

From West Africa there are the following P-values for physical and biological soil conservation measures:

channel terraces	0.1 - 0.2
tied ridges	0.1 - 0.2
reinforced ridges of earth	0.1
stone terraces	0.1
buffer strips 2-4 m wide	0.1 - 0.3
straw mulch (6 tons/ha)	0.01
thick straw mulch	0.001



## HOW THE EQUATION CAN BE USED FOR THE CHOICE OF SOIL CONSERVATION MEASURE

The factors which should be used for Kenya are not yet fully known. However, the examples below illustrate the influence of different factors in soil erosion, thus contributing to a better understanding of soil erosion and soil conservation.

### Example 1 - Calculation of the annual soil loss

Calculate the soil loss (A) on a sandy slope of 4 % with a slope length of 150 feet. Contour farming with maize in Machakos District.

Solution: Assume R = 200 according to p. 24. K according to p. 25 = 0.1. LS according to the chart on p. 25a = 0.5. C as per Example 1 on p. 29 = 0.7. P according to the table on p. 30a = 0.5.

Thus  $A = 200 \times 0.1 \times 0.5 \times 0.7 \times 0.5 = 3.5$  tons/acre.

Conclusion: Contour farming might be a sufficient soil conservation measure in this case.

### Example 2 - Comparison of areas of different rainfall (R-factor)

The conditions are the same as in Example 1 above but the Rainfall factor varies:

- 1) R = 500
- 2) R = 200 (as in Example 1)
- 3) R = 100.

Solutions:

- 1)  $500 \times 0.1 \times 0.5 \times 0.7 \times 0.5 = 9$  tons/acre
- 2)  $200 \times 0.1 \times 0.5 \times 0.7 \times 0.5 = 3.5$  tons/acre
- 3)  $100 \times 0.1 \times 0.5 \times 0.7 \times 0.5 = 1.75$  tons/acre.

Conclusion: The soil loss varies with the Rainfall erosion index. Contour farming is not always a sufficient measure in areas with a large R-factor, even if the slope is only 4 %.

### Example 3 - Comparison of different soils (K-factor)

The conditions are the same as in Example 1 but there are three different soil types:

- 1) sand, K = 0.1 (as in Example 1)
- 2) sandy loam, K = 0.25 according to p. 25
- 3) loam, K = 0.4 according to p. 25.

Solutions:

- 1)  $200 \times 0.1 \times 0.5 \times 0.7 \times 0.5 = 3.5$  tons/acre
- 2)  $200 \times 0.25 \times 0.5 \times 0.7 \times 0.5 = 9$  tons/acre
- 3)  $200 \times 0.4 \times 0.5 \times 0.7 \times 0.5 = 14$  tons/acre.

Conclusion: Contour farming is not a sufficient measure on 4 % slopes with such erodible soils as sandy loam and loam.

Example 4 - Comparison of slopes of different percentages (S-factor)

The conditions are the same as in Example 1, but there are three different percentages of slopes:

- 1) 4 % (as in Example 1)
- 2) 8 %
- 3) 12 %.

Solutions:

The LS-factor for 4 % = 0.5, for 8 % = 1.2 and for 12 % = 2.2 according to the chart on p. 25a.

As can be seen from the table on p. 30a the P-factor also changes for different percentages of slope: for 4 % P = 0.5, for 8 % P = 0.6 and for 12 % P = 0.7 (between 0.6 and 0.8).

Thus:

- 1)  $200 \times 0.1 \times \underline{0.5} \times 0.7 \times \underline{0.5} = 3.5$  tons/acre
- 2)  $200 \times 0.1 \times \underline{1.2} \times 0.7 \times \underline{0.6} = 10$  tons/acre
- 3)  $200 \times 0.1 \times \underline{2.2} \times 0.7 \times \underline{0.7} = 22$  tons/acre.

Conclusion: Contour farming is a sufficient measure for a sandy slope of 4 %, but not for slopes of 8 and 12 % of this soil type.

Example 5 - Choice of soil conservation measure

What is the soil loss and the right soil conservation measure in this example from the Kitale area ?

The rainfall erosion index (R) = 300. The soil is clay, K = 0.2. As the length of the slope is 400 feet, and the steepness of the slope is 8 %, the LS-factor will be 2. Continuous cultivation of maize gives C = 0.7. At present there is cultivation up-and-down hill.

Solution: With a continuous fallow the soil loss would be:

$$300 \times 0.2 \times 2 \times 1 = 120 \text{ tons/acre}$$

and with maize cultivation (C = 0.7):

$$300 \times 0.2 \times 2 \times 1 \times 0.7 = 84 \text{ tons/acre.}$$

How can the various soil conservation measures further reduce this soil loss ? Using the P-values of the table on p. 30a:

- 1) By contouring  $84 \times 0.6 = 50$  tons/acre
- 2) By strip cropping  $84 \times 0.3 = 25$  tons/acre
- 3) By terracing  $84 \times 0.12 = 10$  tons/acre.

However, to find the right figure for the soil loss after terracing, the slope length has to be reduced to the spacing between the terraces.

First, we have to calculate the Vertical Interval (V.I.)

$$V.I. = \frac{\% \text{ slope}}{4} + 2, \text{ in the example } \frac{8}{4} + 2 = 4 \text{ feet.}, \text{ see p. 81:}$$

After that we can calculate the Horizontal Interval (H.I.)

$$H.I. = \frac{V.I. \times 100}{\% \text{ slope}}, \text{ in this example } \frac{4 \times 100}{8} = 50 \text{ feet.}, \text{ see p. 81:}$$

Consequently the LS-factor (see the chart on p. 25a) will be reduced from 2 to 0.7. The soil loss equation will now be:

$$300 \times 0.2 \times 0.7 \times 0.7 \times 0.12 = 3.5 \text{ tons/acre}$$

Conclusion: Terracing will give an acceptable soil loss of 3.5 tons/acre per year.

#### Example 6 - Where bench terraces were needed

In Machakos District there are slopes of 16 % planted with maize, with a length of 200 feet. There are three different soil types:

- 1) sand,  $K = 0.1$
- 2) clay loam,  $K = 0.3$
- 3) loam,  $K = 0.4$ .

Solution: With an LS-factor of 4.1 (chart p. 25a) the soil loss equation would be:

- 1)  $200 \times 0.1 \times 4.1 \times 0.7 \times 0.8 = 46 \text{ tons/acre}$
- 2)  $200 \times 0.3 \times 4.1 \times 0.7 \times 0.8 = 138 \text{ tons/acre}$
- 3)  $200 \times 0.4 \times 4.1 \times 0.7 \times 0.8 = 184 \text{ tons/acre}$

Considering the decreased slope length through terracing (H.I. at 16 % = 38 feet), the LS-factor has to be changed from 4.1 to 1.9:

- 1)  $200 \times 0.1 \times 1.9 \times 0.7 \times 0.16 = 4.3 \text{ tons/acre in sand}$
- 2)  $200 \times 0.3 \times 1.9 \times 0.7 \times 0.16 = 13 \text{ tons/acre in clay loam}$
- 3)  $200 \times 0.4 \times 1.9 \times 0.7 \times 0.16 = 17 \text{ tons/acre in loam.}$

Conclusion: These soil loss figures show that terracing (channel terraces) would be sufficient on slopes of sand but not on slopes of clay and loam.

Solution: The development of bench terraces is recommended on these loam soil slopes, where a reduction of the percentage slope can decrease the LS-factor and the soil loss, e.g. if the bench is

levelled through natural development from 16 % to 8 %, the IS-factor will be reduced from 1.9 to 0.6:

- 1)  $200 \times 0.1 \times 0.6 \times 0.7 \times 0.12 = 1.0$  tons/acre in sand
- 2)  $200 \times 0.3 \times 0.6 \times 0.7 \times 0.12 = 3.0$  tons/acre in clay loam
- 3)  $200 \times 0.4 \times 0.6 \times 0.7 \times 0.12 = 4.1$  tons/acre in loam.

Conclusion: Bench terraces, which develop easily in loam soils, minimize the erosion to an acceptable rate in contrast to channel terraces.

#### QUESTIONS

1. Determine the soil loss in tons per acre for a field in your present district, if  $K = 0.1$ ,  $L = 30$  m,  $S = 12$  %,  $C = 0.7$ , and up-and-down the slope farming is practised. What conservation practice should be adopted, if the soil loss is to be reduced to a maximum of 5 t/a ?  
Use the chart p. 26 and the table p. 30 a.
2. Compute the soil loss from a terraced field in your present district assuming a slope of 8 %, clay loam, maize on the contour and with terraces at intervals of 100 feet.
3. If, in your present district, the soil loss is 15 t/a from a field with up-and-down the slope farming, on a slope of 10 % and a length of 135 m, what will the soil loss be, if the field is terraced with a horizontal spacing of 15 m ? Assume the cropping management conditions (C factor) remain unchanged.
4. If the average soil loss on a slope of 6 % with up-and-downhill farming is 20 t/a, what is the soil loss for contour farming, for strip cropping and for terracing under the same conditions ?  
Use the table p. 30 a.
5. If the degree of slope is decreased from 10 % to 2 %, what is the corresponding decrease in erosion (or in other words, how many times less will the erosion be)?  
Use the graphs on p. 26.
6. If the soil loss for a slope of 10 % and 50 feet long is 5 t/a, what soil loss could be expected for a 10 % slope 200 feet long ?  
Use the chart on p. 25 a.

III SOIL CONSERVATION ON CULTIVATED LAND

C O N T E N T S

	Pages
1 What is soil conservation ?	36 - 37
2 Cultural measures	
Farm management	38 - 40
Companion crops	40
Mulching	41 - 42
Rotation	42 - 43
Contour farming	43 - 44
Ridging	44
Strip cropping	45 - 45 b
Buffer strips	46
Wash stops	46 - 49
Trees	49
3 Physical measures	50 - 51
Cutoff drains	52 - 69
Artificial waterways	70 - 74
Terraces	75 - 98
Costs	99 - 104
Policy of the Ministry	105 - 108

### WHAT IS SOIL CONSERVATION ?

The present topography and distribution of soils is the result of erosion and sedimentation processes over millions of years. Most parts of the earth were originally covered with vegetation, protecting the soil and bringing erosion to more or less a standstill. Erosion occurred only on rare occasions, at some times in every century, usually during heavy rains and floods.

However, the most disturbing factor in historical time is man's activities in damaging natural forests and grass land. The resultant erosion, created and accelerated by man, is "soil erosion" in contrast to the natural "geological erosion".

The following is a list of the various causes of soil erosion:

1. Removal of trees, bushes and grass prior to cultivation, which is especially disastrous on steep slopes.
2. Cultivation up-and down hill.
3. Bad farm management, e.g.
  - a) planting the same crop without fallow for too long a period.
  - b) no rotation of crops, and
  - c) poor crop stand due to lack of fertilizers or organic manure.
4. Overstocking which causes:
  - a) bare patches in the vegetative cover on the ground,
  - b) compaction of the soil through trampling,
  - c) replacement of good grass species by poor annual grasses, and
  - d) development of gullies along stock tracks down the slopes.
5. Burning of vegetation, especially on slopes.
6. Cultivation or overgrazing of river banks, followed by flooding by high water flows.

The degree of soil erosion is often judged on the basis of the thickness of the dark, fertile top soil layer. When so is done, it should be observed that the normal thickness, without any significant soil erosion varies in different environments, e.g.

in forest 2 - 5 cm or more

on savannah 5 - 10 cm or more

on shambas (cultivated for a long time) 10 - 20 cm or more.

A top soil more shallow in these different environments usually indicates soil losses from erosion. The thinner the top soil the more severe the erosion is likely to be, until, as often happens, there is no topsoil left. When such a stage is reached, it is evident from the

poor growth and low yields of the cultivated plants.

Measures taken against soil erosion are called soil conservation measures.

These measures can be grouped in the following way:

1. Cultural or biological measures include all farming practices in which vegetation helps to minimize erosion. These measures aim at good fertility and good structure of the soil, including protection against erosion:

Farm management	Rotation	Strip cropping
Companion crops	Contour farming	Buffer strips
Mulching	Ridging	Wash stops
		Trees

2. Physical measures have as their objective to drain or infiltrate the excess water during rain storms and to retain the moisture in the soil between the rainfalls:

Cutoff drains  
Artificial waterways  
Terraces.

3. Farm planning aims at the optimum land use for farms.

As can be seen from the list above soil conservation is not only a matter of erosion control, but also the wise use of land and good treatment of the soil. There are no sharp limits between the different measures mentioned in the list. This should be regarded as an outline of more detailed descriptions which follow below.

If the cultural measures are sufficient to keep the erosion down, no physical measures will be needed. - On the other hand, physical measures only will not be sufficient. Farm planning considers both cultural and physical measures and will therefore be treated in a separate chapter.

Soil conservation is particularly important in tropical zones, because the rainfall is higher and more intensive than in temperate climatic zones. The rainstorms detach soil particles and break up the soil aggregates. The surface of the ground will become sealed with a thin sheet of clay. This prevents infiltration, thus increasing runoff and erosion.

In Kenya the soil is the most valuable natural resource and, if lost, is irreplaceable.

Adequate soil conservation can increase the area of arable land as well as multiply its yields.

## CULTURAL MEASURES

### FARM MANAGEMENT

When people talk about soil conservation, they usually think of terracing and similar practices. However, good farm management can reduce the amount of erosion much more than terraces, especially on gentle slopes. Good farm management looks after the soil as well as the crops.

#### Soils

Soil properties which reduce erosion include:

1. High percentage of clay, the particles of which are not easily detached by flowing water.
2. Clods and large pores, which give a high infiltration rate.
3. High percentage of organic matter.
4. High fertility.
5. Prevalence of specific chemicals (divalent ions).

No. 1 above regarding the size of soil particles cannot be changed by farm management, but Nos. 2-5, concerning the benefits of cultivation measures, can be affected as explained below.

Clods. -

If the surface of the ground is puddled by rain giving an impermeable sheet, or if it is compacted by the trampling of cattle or heavy machinery, the infiltration rate will decrease. Thus the structure of the soil can affect runoff and erosion risks.

Ploughing, as well as digging with a fork, are in themselves conservation measures, because they produce suitable soil structure. The clods formed by the cultivation give large-pore spaces, which increase the infiltration rate and retain large amounts of water, thus decreasing the runoff and the erosion.

In Senegal the turning of bare soil by hoe or plough decreased the erosion by 64%. There are examples in tropics, where the clod structure has remained, under natural conditions as good as if it had been under a 3 inch of mulch for 17 months. The length of time depends of course on the texture of the soil and the intensity of rainfall. It can be expected, that the length of time is longer in clay soils than in other types of soils.

However, there are also examples from different parts of Africa, of mechanized cultivation increasing the erosion compared with hoeing by hand. Deep ploughing itself creates clods and increases the infiltration, but discing and harrowing destroy the clods. When clods break down, they can seal the pores, thus decreasing the infiltration rate and inducing runoff and erosion.



As big clods from the subsoil are more pulverized than clods from the top soil, ploughing not below 12 - 15 cm is to prefer from the part of view of soil conservation. Disc harrows and chisel ploughs are better than ploughs turning over soil.

Intensive tillage (ploughing and harrowing several times) can increase the artificial runoff and the soil loss three times compared to hand tillage (with a hoe). Actions to decrease the soil moving operations are called minimum tillage.

There is evidence (Fournier's tests in Senegal) that after 6 years of mechanized soil conservation almost all soil aggregates were dispersed and the infiltration rate decreased (from 3.1 - 4.7 cm/h to 1.9 - 2.7 cm/h, e.g. the ground does not any longer absorb the annual sky bursts).

Experience like this is in favour of minimizing mechanized tillage.

If mechanized tillage operations should not be used for weeding, chemicals are needed to kill the weeds.

In small-scale farming holes can be made by hand for sowing or planting, leaving the structure of the soil unchanged on both sides of the row of holes. To avoid disturbances by weeding by hand, chemicals have to be used. At present this method is too expensive for labour intensive small-scale farms. Further research is needed.

The figures below (by Lal from Nigeria) show that erosion does not increase with the slope in no-tillage systems (cowpeas at two weeks after planting, rainfall 63 mm):

Slope %	Runoff %		Soil loss (tons/ha)	
	Bare ploughed	No-till	Bare ploughed	No-till
1	69.8	1.3	1.0	0
5	71.9	1.6	2.6	0
10	74.0	3.2	19.6	0.01
15	87.6	2.7	33.3	0

**Organic matter. -**

Organic matter increases the aggregation of soil particles and makes the aggregates more water-stable. The reason is ionic bonds between clay particles and organic substance. (The outermost ions of opposite charge of the two materials are attached to each other.) As a result of this aggregation the infiltration and percolation rates will be increased, thereby decreasing the runoff of water and its erosion. The porous organic matter, decomposed or not, increases the water holding capacity of the soil. Decomposed organic matter increases the mineral nutrients available to plants.

**High fertility. -**

High fertility results in good growth of crops and is the best insurance against rain drop erosion. The protection of the soil is proportional to the horizontal growth of the plants. Compare the two drawings below.

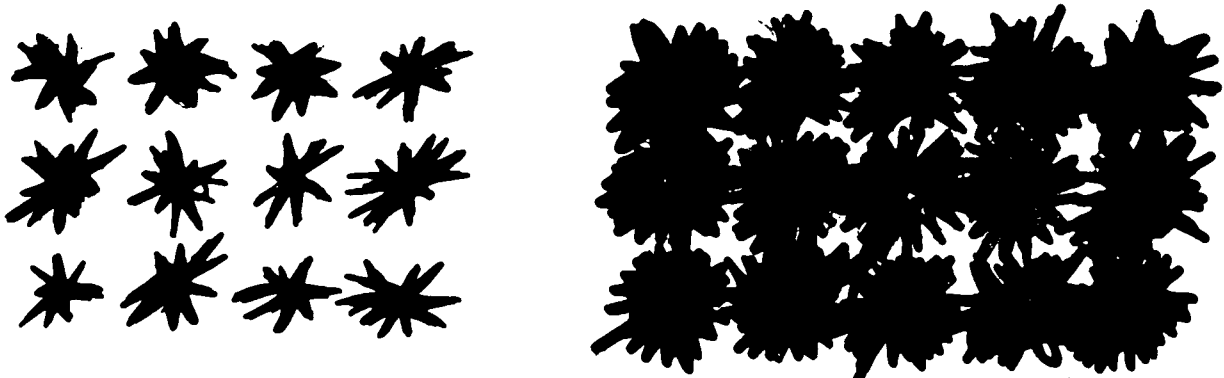

The large raindrops of heavy rains will hit the leaves instead of the ground, and drip to the ground without sufficient force to erode the soil. An improved crop density can reduce the area of bare ground from 40 % to 10 %, thus reducing the raindrop erosion by four times.

How differences in crop density influence the cultivation, can be seen from the following example (Hudson 1959):

	Field No. 1	Field No. 2
Production (fertility) of maize	5 bags/acre	20 bags/acre
Area needed for the production of 1,000 bags	200 acres	50 acres
Soil loss per year	20 ton/acre	5 ton/acre

From these figures it can be calculated that 1 ton of maize can cost 40 tons of soil (on field No. 1) or 2.5 tons of soil (on field No. 2).

**Specific chemicals (divalent ions)-**

Specific chemicals, especially calcium from fertilizers, increase the shear strength of clay soils. Such a stabilization of the soil makes it more resistant to rain and erosion.

## Crops

### Early planting. -

Early planting is important in East Africa, as much of the erosive rains comes during the beginning of the rainy season. However, at this time cracks are still open, reducing runoff and erosion.

An early planting during the rainy season will develop better plants and give protection against soil erosion e.g. the mean annual soil loss in an experimental tobacco field was three times greater after late planting compared to early planting.

### Choice of crop. -

On erodible soils the choice of crop for cultivation should be considered. The soil loss through erosion varies according to the type of plant, providing that it is well established: grass (least soil loss), small grain crop, maize, cotton, peanuts and cassava (most soil loss). There are great differences in soil loss between the various plants. The erosion is at least five times greater on a field with a small grain crop than on a pasture. The soil loss from a field of clean-tilled cotton can be 50 % greater than from a field of maize.

### COMPANION CROPS

The question of intercropping or "companion crops" is contradictory. Interplanting of cotton with maize in Kenya has given good results, but trials with maize and beans have given the same cash return whether mixed or in pure stands. However, mixed cropping, practised for a long time by smallholders in Kenya is conducive to less soil erosion. Further, it can be assumed that the interplanting of beans or other legumes between the rows of maize makes a rotation less necessary.

Examples of other companion crops are: 1) maize + cassava, or sweet potatoes, cotton, ground nuts, simsim, pigeon peas, grams or sun flower 2) pigeon peas + beans or millet, 3) cotton + millet or grams or coriander 4) bana grass + legumes. Ploughing by oxen makes interplanting difficult.

The table below shows the benefit of companion crops in decreasing annual runoff and soil loss due to erosion. The trials were carried out on a slope of only 5 % in South Africa. The soil losses would have been much larger on slopes more than 5 % and in areas with intensive tropical rains.

Treatments	Annual runoff in % of rainfall	Annual soil loss in tons/acre
Bare soil, not worked	32	11.5
Maize, not fertilized	10	3.6
Maize + mineral fertilizer	9	3.1
Maize + mineral fertilizer + companion crop	6	2.1

## MULCHING

### Normal mulching (or stubble mulching)

Mulching is using dead plant residues as a cover over the ground. Examples of suitable mulches are banana-leaf mulch and a mulch of grass. As for maize, the stalks can make seed bed and planting operations more difficult than without mulching. It is recommended that the trash should be applied once a year, at the end of the long rains.

Mulching is indeed one of the most effective methods to minimize erosion. There are several reasons for this:

A crop residue covering the ground decreases rain drop erosion, slows down the water flows and increases the infiltration rate as the pores of the soil are not clogged (through surface-sealing by clay particles after rains). It also encourages insects and worms to make holes into the ground, thus increasing the permeability of the soil to a large extent. Mulching is also effective against wind erosion, which may be dangerous between the cropping periods, especially on sandy-silty soils.

A straw mulch can reduce the soil loss through erosion by 95%. In experiments in Ohio a layer of straw mulch was laid on a wire platform 1 inch above the ground, and this arrangement did not decrease the soil loss. This demonstrates the importance of rain drop erosion compared with superficial water flows.

The effectiveness of mulching for infiltration is demonstrated by the graphs below (based on figures by Holtan and Kirkpatrick, 1950):

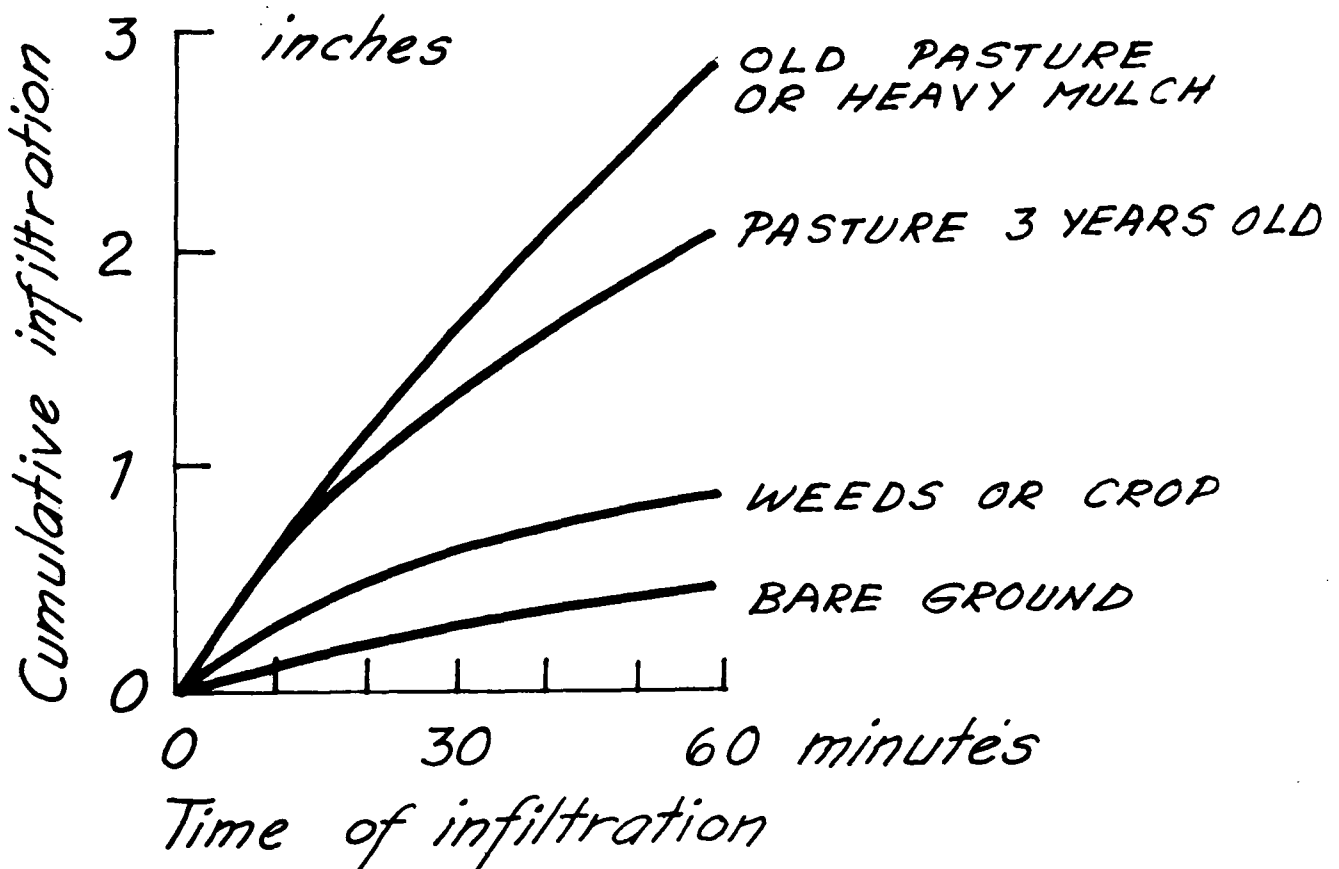

Not only does mulching reduce the soil loss but it also reduces the deterioration in soil texture caused by erosion. It has been reported from different parts of Africa, that erosion removes particles of clay + humus and silt more easily than sand from the shambas. Consequently the longer the shamba soil is cultivated without soil conservation measures the coarser it will become.

Mulching can also increase the crop yields by 27 %, according to an experiment in Kenya. Sometimes, however, the mulch is eaten by termites.

When starting the cultivation of tea it is recommended to put 1 m wide strips of mulch between the rows of planted tea (a spacing of about 1.5 m)

In the dry Sahelian and Sudan areas the incorporation of organic residues reduces the crop yields at least during the first year, probably due to insulation of the topsoil and reduction in capillarity.

#### Trash farming

Trash farming means ploughing in crop residues. This method is little used in the tropics to prevent erosion, one reason being that maize stalks ploughed in will be eaten by termites.

#### Green manuring

"Green manuring" is the ploughing in of young growing plants into the soil. This method, recommended in many parts of the world, has not been accepted by small-scale farmers in Kenya. The measure protects the soil against soil erosion, but as to the manuring effect, experiments in the Trans Nzoia have shown a yield increase only in the following season. Farmers in Kenya prefer using compost manure instead of the practice of green manuring. In fact the compost has a better effect on the crumb structure of the soil, and the stalks in the compost are not eaten by termites.

#### ROTATION

Maize should, if possible, be rotated with grass since grass gives a good crumb structure to the soil. Regarding erosion control the rotational periods should be short. Usually a rotation in 3-year periods is recommended.

Another advantage of a rotation with grass is that this can be used for cattle, which produce manure. In trials at Matuga 3 tons/acre of farmyard manure applied yearly maintained fertility and was as good as an equivalent amount of nitrogen, phosphorus and potassium as inorganic fertilizer. Thus organic manure can compete with inorganic fertilizers, but a combination

of organic and inorganic manuring gives a better result than only one of them.

The benefits of crop rotation can be illustrated by the following figures from Ohio (slope 20%, soil = silt loam, rainfall = 960 mm/year):

	Runoff as % of rainfall	Soil loss tons/acre
Continuous maize	40	98
Crops in rotation: maize	24	42
wheat	25	6
ley 1st year	18	0.6
ley 2nd year	13	0.2
Permanent pasture	4	0.002

### CONTOUR FARMING

A synonym of contour farming is contour cultivation or simply contouring. Strictly speaking contouring is not always exactly along the contour (level) but can have a similar gradient to that of terraces and cutoff drains.

Even if maize is planted by hand, this should be in rows across the slope (along the contour). When the maize plants are about 1 foot high, the rows should be slightly ridged to prevent water from flowing down the slope.

If you use a plough for contour farming, this is called contour ploughing. The effectiveness of plough furrows in collecting water is greater on gentle slopes than on steep slopes, which is explained by the drawings below:

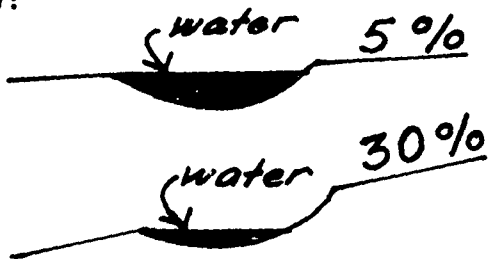

A channel on a 5% slope can hold more water than the same size of channel on a 30% slope.

The erosion in plough furrows along the contour does not remove so much clay and carbon as erosion in furrows up and downhill according to measurements on slopes of 0.5% in Upper Volta (Christoi 1966):

	erosion t/ha	% clay	% sand	% C
natural soil	-	3	73	0.3
eroded through cultivation:				
along the contour	1.5	5	83	0.5
up and down hill	6.3	26	29	2.25

The decreased run off in contour cultivation permits a better retention of the nutrients.

Consequently an increased yield can be expected through contour ploughing

The risk in contour farming is that depressions in the rows can cause an overspill of the collected water which will start to flow down the slope, causing large rills or small gullies. Contour farming is not a suitable method, if water flows and rills cut through the ridges. Nowadays contour farming is practised all over Kenya and cultivation up and down hill is becoming the exception in small-scale farming. In large-scale farming, however, it may sometimes be difficult to plough along the contour. A normal tractor can safely and economically work on slopes of up to 17 %. On steeper slopes the risk of overturning increases. But a four-wheel-drive tractor can work on slopes of up to 25 %.

RIDGING (or listing)

Ploughed ridges can be enlarged by hand or by ridging equipment drawn by oxen or tractors. This method is used in East African countries in such crops as maize, sorghum and cotton. After harvesting the crop residues can be buried when the ridges are broken down.

In Kenya, however, ridging is not common except with tobacco and potatoes. Ridging can increase the risk of overflows after heavy or prolonged rain because the ridges made by farmers are not perfectly graded or completely level. Large ridges can increase wash erosion compared to those on flat land, because the ridges consist of loose soil and have steep sides.

Investigations in Nigeria (Kowal 1970) have shown that very large ridges (0.9 m) increase soil erosion by 5 times. Further the soil erosion on ridged fields is more selective than on fields without ridges: the loss of fine material (organic matter, clay and fine silt) is 3 times greater, and the loss of plant nutrients (soluble and exchangeable bases) twice as much.

To overcome the risk of erosion tied ridging (basin listing) is used, especially in parts of Tanzania and Uganda. Tied ridging can increase the yields in semi-arid areas, but it should not be used where there is a risk of waterlogging, i.e. in soils with a low permeability in areas with a high rainfall.

Instead of continuous basins, pitting is used in parts of Kenya, the pits being 0.75 m deep:

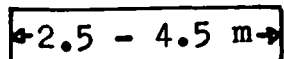

Tied ridging and pitting can easily retain the water from a 3 inch storm. Another advantage is that the ridges need not necessarily be cut accurately on the contour.

STRIP CROPPING (see also p. 7)

Contour strip cropping promotes good soil structure and decreases erosion by waterflows. Rain erosion is decreased on the alternating wide strips of grass, but still proceeds on the cropped strips. Total strip cropping can reduce the soil losses considerably.

The disadvantages of strip cropping are:

1. The long and narrow plots are difficult to graze, as they usually require fences.
2. Grass hoppers tend to concentrate on the borders of the crop strips.

In Kenya strip cropping could be practised more in those districts where the pastures are as large as the crop land. The wide strips of pasture and crops are sometimes bordered by narrow grass strip terraces, or by channels diverting surplus water. This combination of strip cropping and terracing could be used, if every second terrace (according to the usual rules for spacing) was removed and a rotation was introduced.

Strip cropping is best on permeable soils and on slopes which are not too steep, preferably not exceeding 15 - 20 %. In Kenya the maximum widths of crop strips might be:

- |                |  |
|----------------|--|
| 30 - 20 %      | tentatively 10 m, or closer if experience demands it   |
| 20 - 12 %      | according to the textbooks and observations made in Kenya about 20 m   |
| less than 12 % | a formula can be used for calculation of the width in feet:<br>$168 - (7 \times \% \text{ slope})$ , e.g. for a 10 % slope<br>$168 - (7 \times 10) = 98 \text{ feet} = 33 \text{ m}$ |

If the farmers are not interested in terracing of steep slopes (wash stops developing into bench terraces or digging terraces), wide vegetation strips might be an alternative, i.e. contour belts of trees or bananas combined with some kind of strip cropping (e.g. maize - grass or maize - sugar cane). See the figures on the next page.



Cultivation alternatives  
on a very steep slope of  
50 %

### MODIFIED BENCH TERRACES

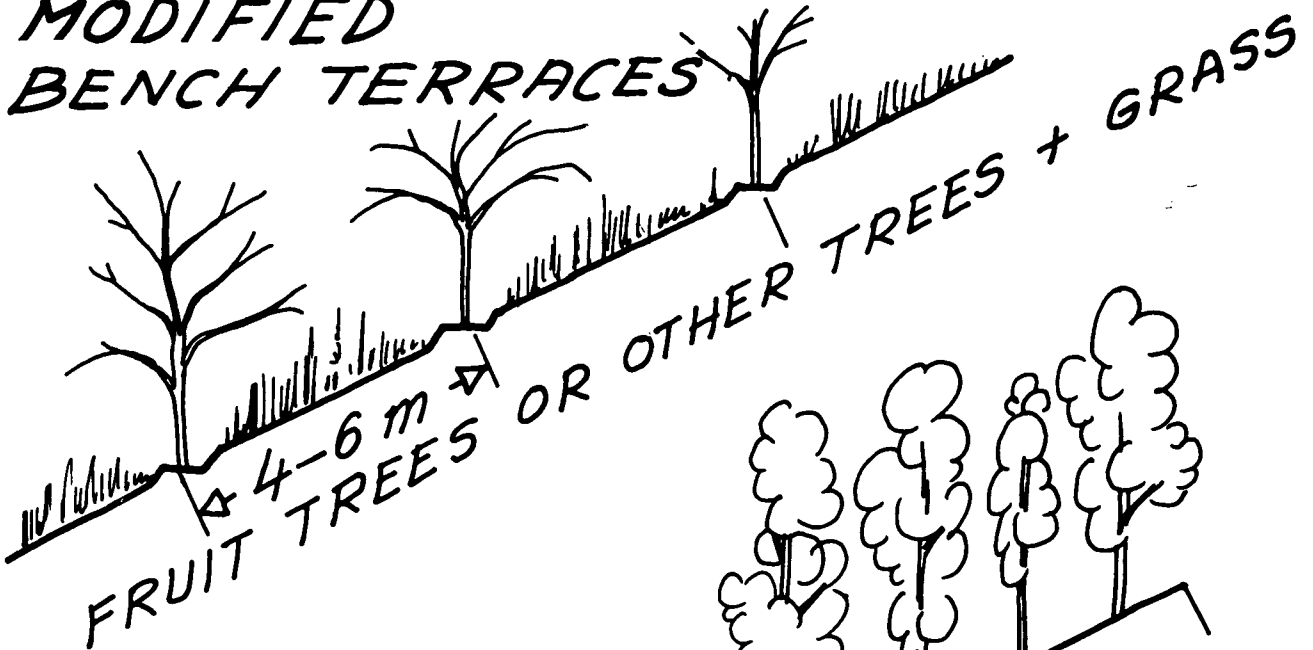

### STRIP CROPPING: ALTERNATIVE 1

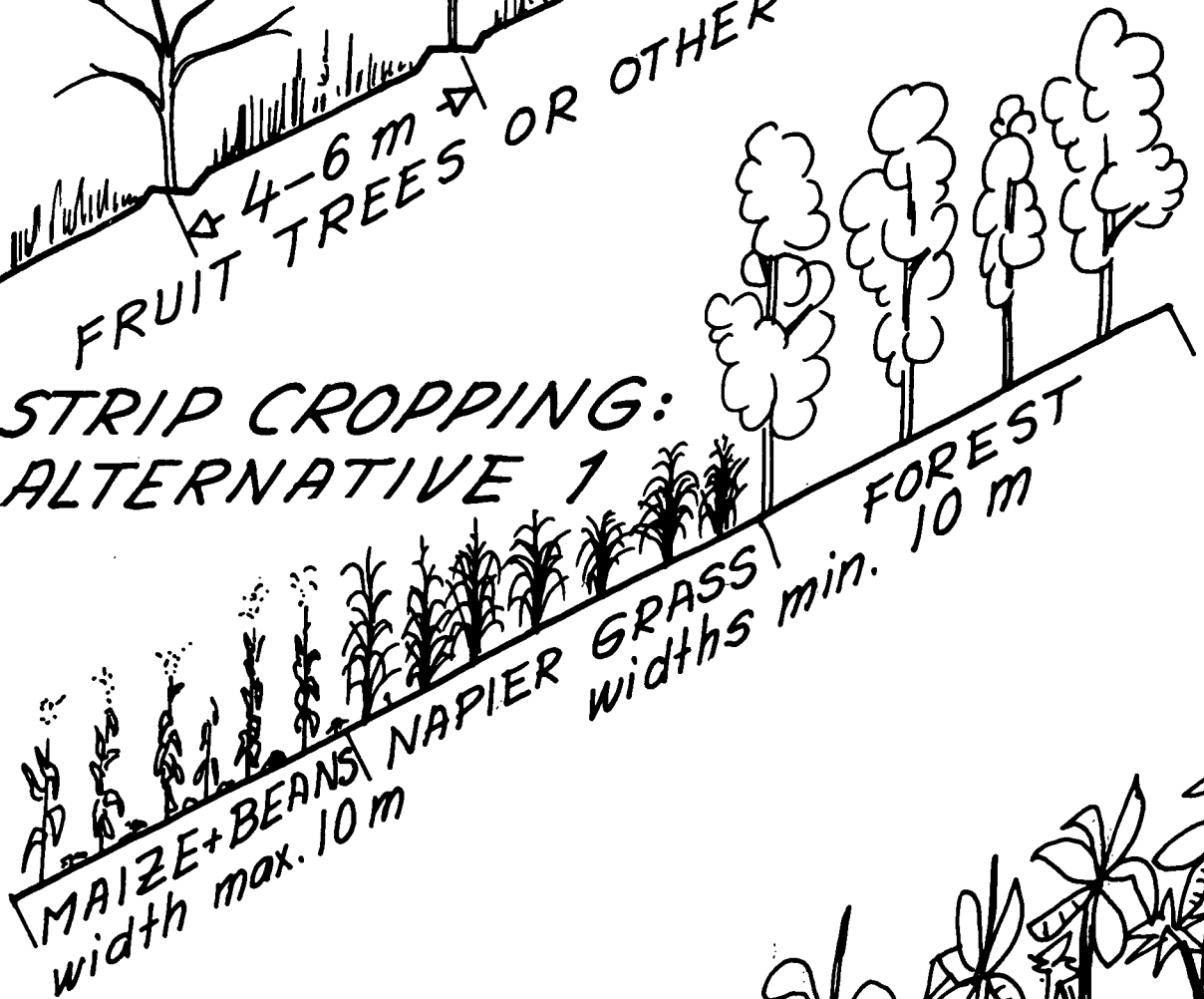

### ALTERNATIVE 2

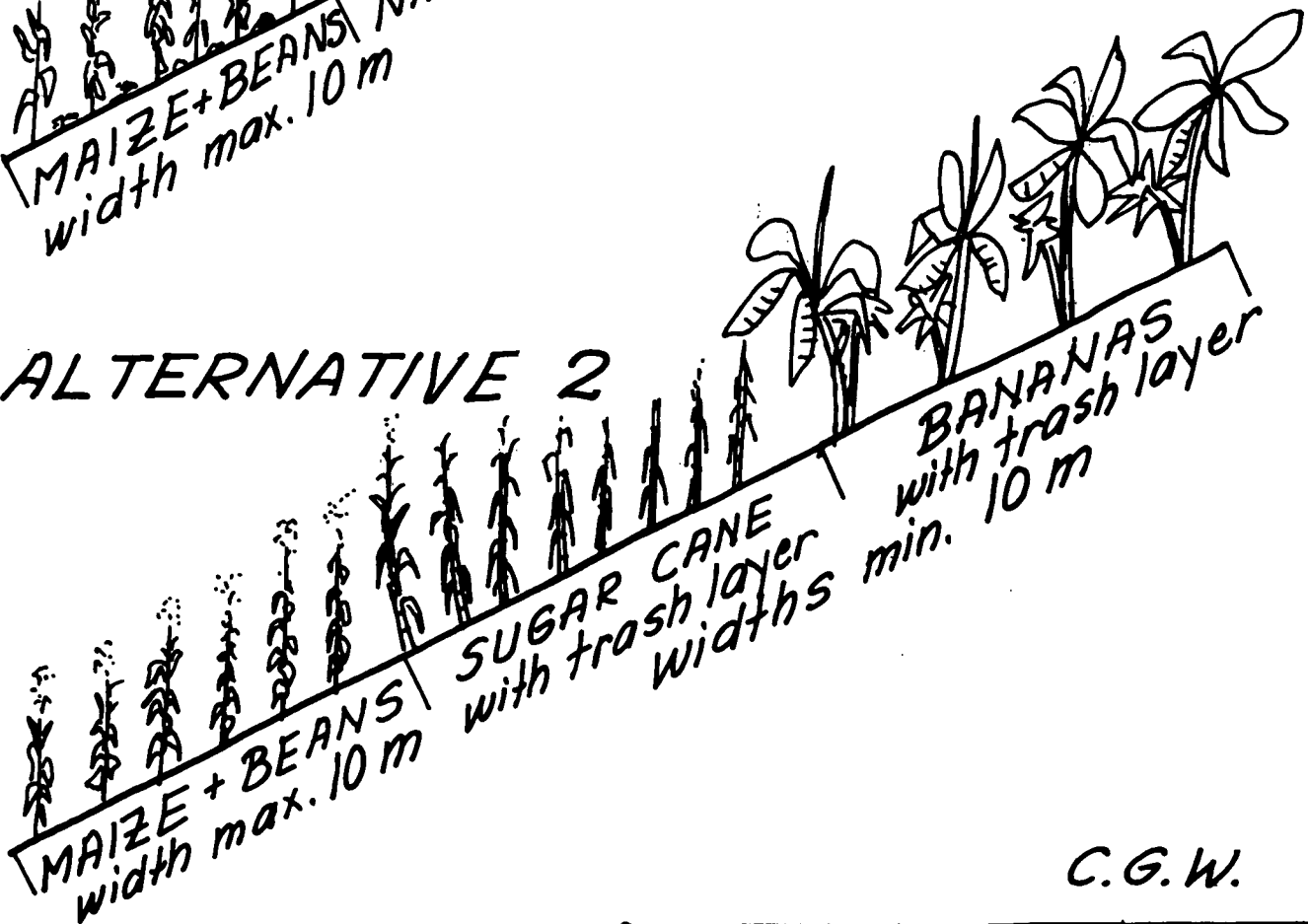

C.G.W.

## BUFFER STRIPS (AND OTHER WIDE VEGETATION STRIPS)

If grass cannot be rotated for normal strip cropping, and if the area has easily eroded soils, wide strips of permanent grass (or a legume or grass+legume) can be used. The width is usually about 2 m (1.2 - 4 m). The widths of the grass strips can vary, but the cultivated strips between the grass strips are recommended to have the same width to facilitate ploughing, especially when using oxen or machinery. The idea is that the water flows should infiltrate into the grass/legume strips. The width of grass strips used in Kenya (0.5 - 1.5 m) is usually sufficient, as terraces with strips have been seriously damaged on only two occasions since the 1920s.

On gentle slopes a semiperennial or perennial crop can be used, instead of grass (buffer strip cropping), especially if dead plant material can be left as a trash layer over the ground, e.g. sugar cane or bananas. Alternatively row crops can be used, e.g. sisal or pineapples, planted close together in rows on small ridges, which should be maintained.

On steep slopes there is an obvious risk of rill erosion between the weeded plant stems. To prevent erosion on such vegetational strips, the overland flow from the slope above the strip can be diverted along a graded ditch, along the upper or lower edge of the strip. If along the upper edge the ditch will be a channel terrace, with the excavated soil thrown downhill ("fanya chini terrace"). In erodible soils this method will need annual maintenance, which will delay or prevent a benching effect. If the water is diverted along the lower edge of the slope the soil should be thrown uphill ("fanya juu terrace"), which will create a bench terrace for the crop. In most cases on steep slopes it would be sufficient to have only a channel terrace or a fanya juu terrace without any extra vegetation strip.

## WASH STOPS

A wash stop should not be regarded as having a damming effect in stopping wash erosion. It is rather a means of distributing water flows into small non erodible flows and infiltrating these into the ground, where root holes and channels made by animals are not removed every year by cultivation.

There are four main types of vegetation wash stops:

1. Trash lines
2. Grass strips
3. Sisal hedges
4. Bush hedges

Trash lines (trash bunds)

Temporary or sometimes permanent trash lines have been used in Kenya for generations, often only 6 m apart, and even on slopes of 2 - 12 %. Trash lines are recommended as a first measure to develop bench terraces. After 1 - 2 years local grasses will grow up along and through the trash lines, stabilizing them. In some areas it is necessary to put pegs along the lower side of the trash line to keep the trash in position, until the trash line has been stabilized by the grass.

If there is a risk of stalk borers in the area, the stalks of maize should not be used for trash lines but should be burnt or taken to a compost heap.

Grass strips (As to species see p. 96).

Grass strips are widely used on slopes in various parts of East Africa. The width is usually about 0.5 m but sometimes up to 2 m. The latter width was recommended a long time ago, but this recommendation was not followed by farmers. The simplest way to create grass strips is to leave strips of land unploughed along the contour (e.g. 1 m wide) to enable local grasses to come in, and after a period of time establish a grass cover. This type of establishment has been recommended for instance in Narok District for slopes of wheat cultivation.

Grass strips are usually graded. In erodible soils grass strips develop into bench terraces. See Fig.1 on the next page.

Level grass strips have been used in the drier parts of Kenya even on gentle slopes (less than 6 %), and these have created narrow level areas above and along the grass strips. This type of terrace, practised by Kenyan farmers for a long time, is similar to a type of level terrace used in the semi-arid areas of the USA and called a conservation bench terrace (or infiltration terrace or the Zing conservation bench terrace). The runoff from the areas between the grass strips is collected on the silty or sandy bench, where it is infiltrated into the ground, increasing its moisture. See figure below:

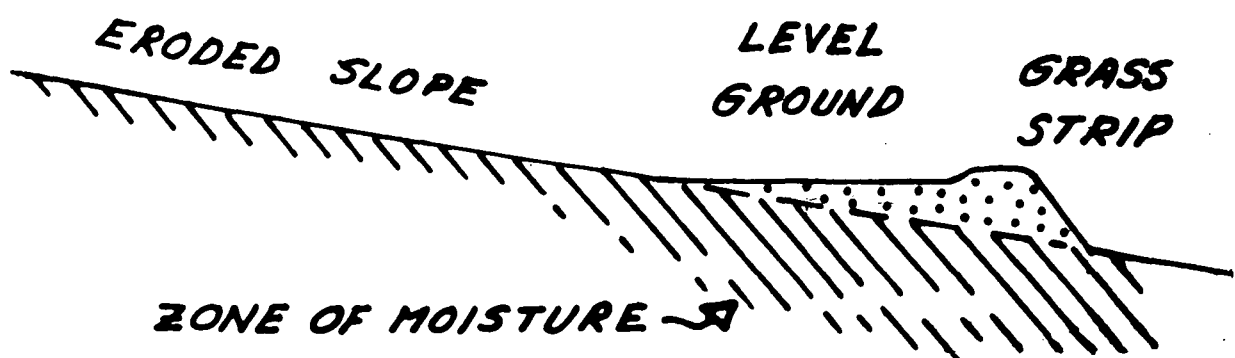

Development of grass strips  
into bench terraces

Fig. 2

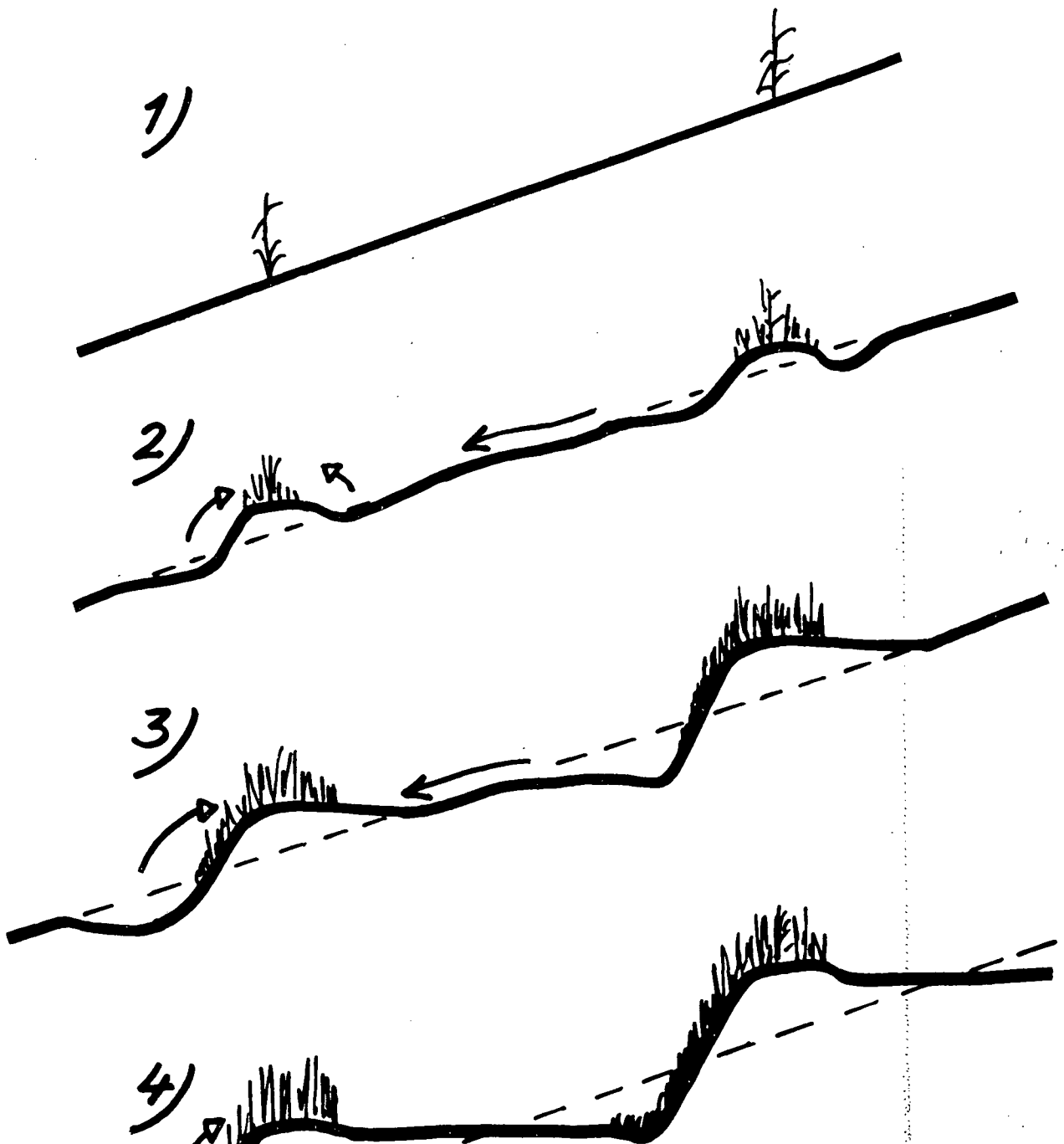

The pictures show how erosion and cultivation move soil downhill → developing bench terraces on a slope of 35%

Maintenance ↗

C.G.W.

In sloping tea fields wash stops may be needed during the period of establishing the tea bushes. Interplanting can be done of oats, wheat or barley in a single thick row, which should be cut before they seed (Mandi 1971).

#### Sisal hedges

Rows of sisal on gentle slopes of erodible soil have been very effective in creating benches for infiltrating water. Sisal can be used in the cotton-sisal zone, and also in the lower parts of the coffee zone. On steep hill sides with shallow soils the spacing between the sisal rows is often too wide, e.g. 20 m creating very high and narrow terraces, but with erosion still continuing between the terraces. In such cases the spacing should be about 5 m, or this method should not be used. Sisal hedges usually have a bottom cover of grass and weeds preventing rill erosion between the sisal plants.

#### Bush hedges

Most bushes are ineffective as wash stop plants. However, bushes such as *Coleus barbatus*, *Euphorbia* and *Crotolaria* may be used on gentle slopes (less than 6 %). On steep slopes (especially of more than 20 %) bushes are apt to increase erosion according to reports from different parts of East Africa. It is probable that this is due to water flows from stems of the bushes.

On a gentle slope of 2 % the benefit of hedges in soil conservation can be seen from the following data from Tanzania. The soil is a red loam:

Treatments	Annual runoff in % of rainfall	Annual soil loss in ton/acre
Cultivation without wash stop	39	5.5
with a Finger <i>Euphorbia</i> hedge	24	2.2

Bush hedges will be more effective when trash (of maize stalks, weeds, banana leaves) is laid along the upper side of the hedge. In this case the row of bushes prevents the trash from moving downhill. Bushes for soil conservation should be cut to maintain a height of 3 - 4 feet.

#### TREES

As the area of forests in Kenya is only 3 % of the total area and since this area decreases every year, there is a national interest in planting trees, not only in the forest reserves but also on farms. The combination of trees and crops is called agro-forestry, which will be treated in more detail in a later chapter (Chapter V).

## PHYSICAL MEASURES

Physical soil conservation measures should be planned on the basis of water sheds, e.g. valleys or parts of valleys.

A survey for physical soil conservation should start with an examination of the topography to find out the directions of the potential overland flow. At the same time it is necessary to locate waterways for discharging water from terraces and cutoff drains, if any.

On small-scale farms in high-potential areas the main soil conservation measures are:

- 1) Cutoff drains (Fig.2)
- 2) Artificial waterways (Fig.3)
- 3) Bench terraces (Fig.3)

Investigations on soil losses, using different physical measures under various conditions, have yet to be effected in Kenya. The following chapters on physical measures are based on the literature available in Kenya and the experience gained there, in particular from field observations.

Measures against gully erosion (gully control) are given in Chapter I: "Erosion processes and their preventive measures" and in Appendix 1.

Cutoff drain and terracing

Fig. 2 - 3

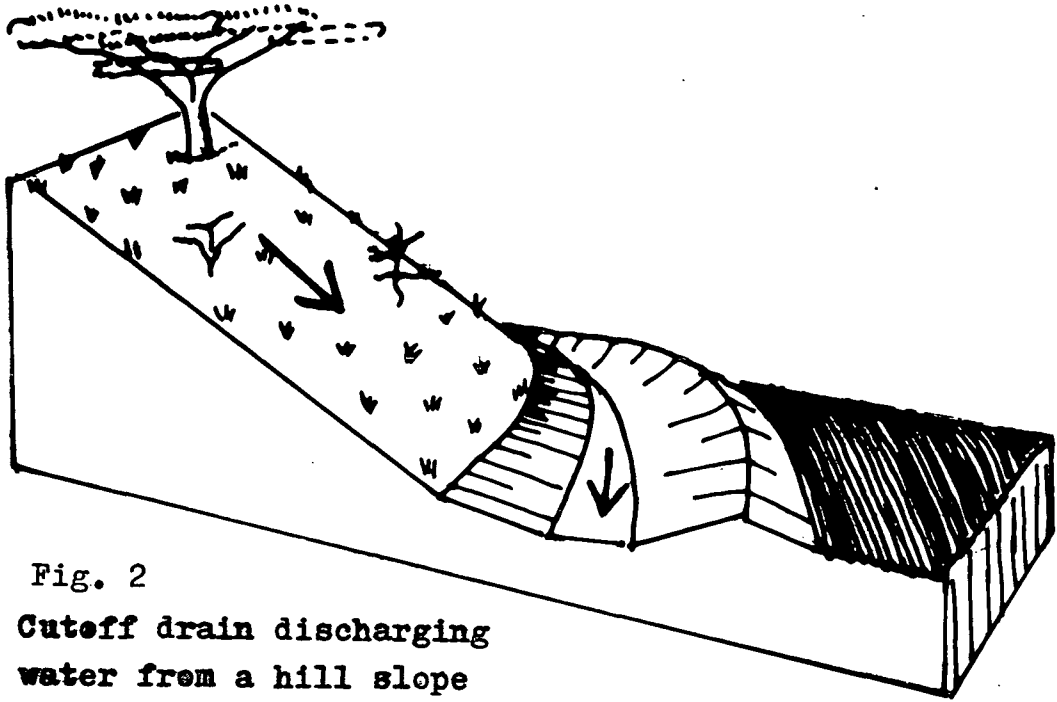

Fig. 2  
Cutoff drain discharging  
water from a hill slope

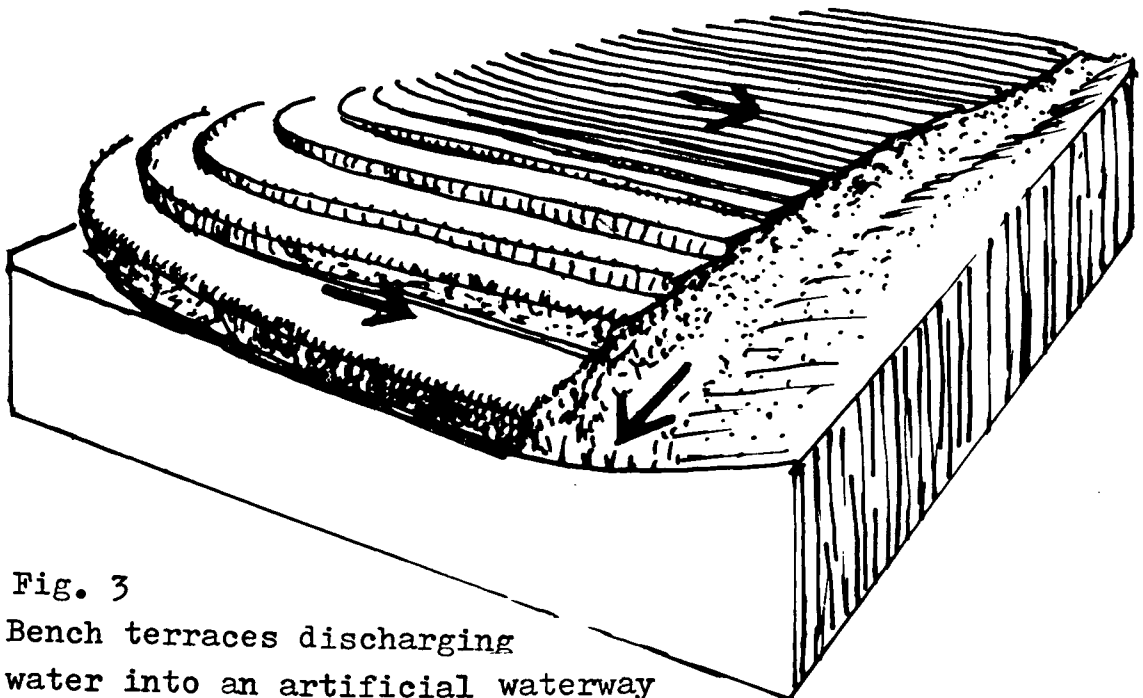

Fig. 3  
Bench terraces discharging  
water into an artificial waterway

C.G.W.

## CUTOFF DRAINS

### What is a cutoff drain ?

A cutoff drain (synonyms: storm drain, diversion ditch, training bank) is an open trench with an embankment on the lower side.

### Need for cutoff drains

Cutoff drains protect cultivated areas from the erosion by water flows. They can also be used for gully control. In deep sand, however, it might be difficult to maintain cutoff drains, because they will be filled up by the sand.

Cutoff drains on cultivated slopes are only a part of the soil conservation. They should be combined with other measures, otherwise rain will cause soil erosion between the cutoff channels. The cutoff drains mainly prevent large flows down the slope which create rill and gully erosion. Cutoff drains should be constructed only where the need is quite evident, i.e. the need is made obvious by erosion rills, or if the farm needs protection from water flows coming from areas outside the farm.

Grass/bush land should not usually be conserved by cutoff drains, unless large gullies exist which are rapidly increasing and thus devastating the land. The correct measure for bush/grass land is contour ploughing (or rippling), not necessarily across all the slope but at least in strips. After ploughing or rippling, the area should be fenced and re-seeded, or natural grasses allowed to regenerate by themselves. An alternative measure is to stop the grazing to establish a good grass cover. If a cutoff drain is needed for gully control, it should not be dug until a grass cover has been established round the gullies as well as on a wide strip above the cutoff drain.

### Survey of site

Preferably cutoff drains should be dug along the break points of the slope, either where a plateau changes into a steep valley side, or where a long slope of a hill changes into flatter land. One reason is to collect water flows from plateau areas, before the water enters slopes, or from hillsides, before the water flows out over cultivated land.



If there are no break-points, the right site for cutoff drain is in the middle of the slope and not on the lower section of the slope, because in such a case only a relatively small area will be protected by the cutoff drain. If the slope is very long (several hundred metres) it may be convenient to dig more than one cutoff drain on the same slope.

Sometimes it is possible to combine a cutoff drain with a road bank the channel being along the upper side of the road bank.

### Discharge of water

A cutoff drain should be discharged:

- a) into a natural waterway (river), or
- b) onto non erodible stony-rocky ground, or
- c) onto grass land with a well established grass cover and without bare spots, or finally
- d) into an artificial waterway.

As to the various possible discharge areas the following points should be noted:

If the bank of the river, into which the cutoff empties its water, has steep sides, the outlet should be stabilized with stone paving or sodding.

Alternatively the cutoff drain should not drop vertically down to the river but should be given a small gradient down the bank of the river.

If the water is discharged onto grass land (permanent pasture), it is common practice to widen the end of the cutoff drain to distribute the water over the grassed slope.

If the cutoff drain water has to be discharged through an artificial waterway, this construction work could be regarded as a continuation of the cutoff drain, and the cost could consequently be met from governmental funds if available.

Sometimes it is possible to combine the construction of a cutoff drain with the construction of a small dam in order to store the water for stock.

Do not discharge the water to other parts of the shamba or onto foot paths. If you cannot discharge the water safely, do not construct any cutoff drains.

### Cross-section

After deciding the location and the number of cutoff drains required, the size of their cross-section should be considered.

Usual size and design. -

The average cutoff drain in the present project areas is 2 feet deep and 3-5 feet wide. A lesser depth than 1 foot is not recommended, because of the risk of silting up during heavy rains. Near the top of small hills or on short slopes the average width is 3 feet, whereas cutoff drains, which collect water from wide/long slopes or from road ditches, often have a width of 5 feet or more. If the cutoff drains are long, they should in principle be dug wider towards their outlets, e.g. the upper part of the cutoff drain could be 3 feet wide, the middle part 4 feet wide and the lower part 5 feet wide. However, cutoff drains are usually given the same dimensions, that is the size of the outlet point.

It is easy to dig a rectangular cross-section with vertical walls, but the walls will be more stable if given some inclination e.g. if the mid width is 4 feet, the top width might be 5 feet and the bottom width 3 feet (see Fig. 4a on the next page). The inclination chosen depends on the soil and local experience. It is desirable to keep an embankment downhill of the channel, because the embankment will increase the cross-section. After exceptionally heavy rain storms the channel could be flooded, well needing the embankment as a margin of safety to prevent overspill. It is wise to leave a ledge of ground between the excavated channel and the filled-up embankment (see Fig.4b), so that soil will fall down on to the ledge, and not into the channel. The ledge might be 0.5 - 1 foot wide.

The width of channel + embankment, i.e. the strip of land not cultivated with crops, is about 3 times the width of the channel itself (see Fig. 4c). No farmer has complained or refused to have a cutoff drain dug across his land.

Design for catchment areas of less than 25 acres using a table.-

In Malawi the top and bottom widths of a cutoff drain in feet are read from one single table:

Catchment area of the cutoff drain in acres	Catchment area having:							
	slopes less than 25 %				slopes more than 25 %			
	Subsoil along the drain being:				Subsoil along the drain being:			
	light		heavy		light		heavy	
	at top	at bottom	at top	at bottom	at top	at bottom	at top	at bottom
5	5	2	3	1	7	4	3	1
10	8	5	4	1	11	8	5	2
15	11	8	5	2	15	12	7	4
20	14	12	6	3	17	13	9	6

Depth always at least 1.5 feet.

Cross-sections of  
a cutoff drain

Fig. 4

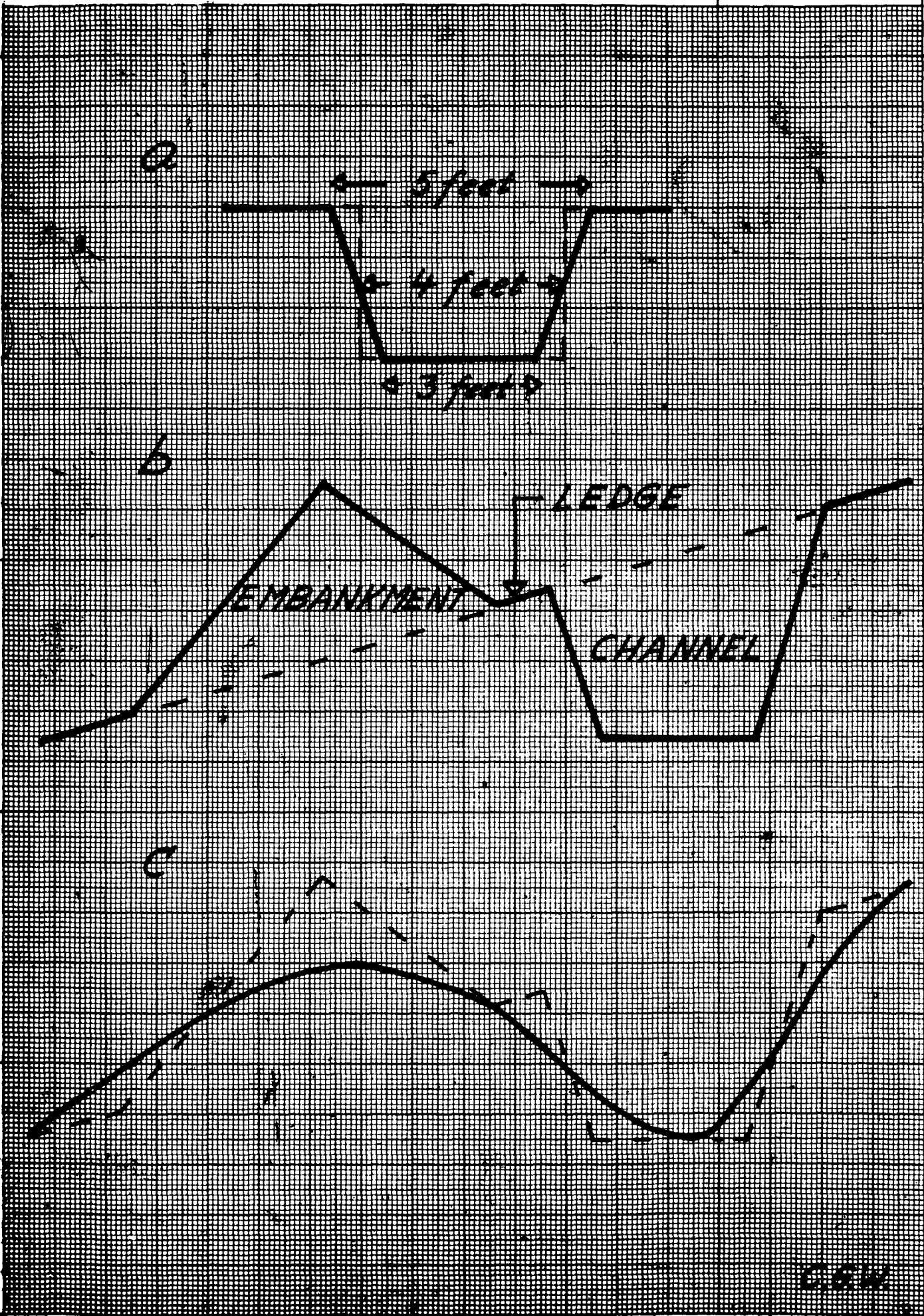

The size of a cutoff drain with good bench terraces above or below can be less than the figures given in the table. But how much less is difficult to say. For slopes with bench terraces, the figures for heavy soils in the table may be used tentatively for all soils until greater experience is gained. If the cutoff drains turn out to be too small, they can be enlarged later on; or the ditches below the grass strip risers of the terraces enlarged.

The design procedure should be:

- 1) Find a suitable outlet point for the cutoff drain and walk along the contour to check that there are no obstacles such as houses or rocky outcrops.
- 2) When returning to the outlet point try to determine if the subsoil is light (sand, silt, sandy loam) or heavy (sandy clay, loam and clay).
- 3) Determine the catchment area of the cutoff drain by estimating how many acres will discharge their rainfall runoff into the cutoff drain.
- 4) Use a quickset level or a line level for the layout of the cutoff drain - in light soils at a gradient of 0.25 % (= 1:400), in heavy soils at 0.5 % (=1:200).
- 5) Determine the top and bottom widths of the channel using the table on P. 54. The figures of the table postulate a constant depth of 1.5 feet.

Example: A catchment area of 5 acres, consisting of steep slopes and with clay soil along the cutoff drain, demands a channel 1.5 feet deep and 3 feet wide at the top, and 1 foot wide at the bottom.

#### Design using Cook's and Durbach's methods -

Different methods of calculation of the size of the cutoff drain may give different results, which indicates the inefficiency of calculations. Calculations are only there to help you design the right size of channel for the discharge of water.

If the farmer thinks that your calculation has given too small or too large a cross-section, take note of this if you think it is reasonable. But remember that no soil conservation system can discharge all the water during extremely heavy rain storms.

# 1. Calculation of surface runoff

(Cook's method)

Cook's method is suitable for soil conservation works in rather small catchment areas (runoff areas).

Under African conditions there are high rainfall intensities even in dry areas. The runoff is influenced more by the local surface conditions within the catchment area, than by rainfall intensity. Consequently rainfall intensity can be disregarded in the calculations.

The calculation of the runoff is based on the following characteristics of the area: 1) vegetative cover, 2) infiltration rate of water into the ground, and 3) topography inclusive of slopes. The table below shows the numerical values for these three characteristics under African conditions:

1) <u>Vegetative cover</u>	2) <u>Infiltration rate</u>	3) <u>Topography</u>
Forest or thick grass cover 10	Well drained soils, e.g. sand 10	Flat land or gentle slopes (0-5%) 5
Scrub or medium grass cover 15	Moderately pervious soil, e.g. silt 20	Moderate slopes (5-10%) 10
Cultivated land 20	Slightly pervious soil, e.g. loam 25	Rolling or hilly land (10-30%) 15
Bare or sparse cover 25	Shallow soils with impeded drainage 30	Steep slopes (exceeding 30%) 20
	Clay and rock 40	Mountaineous 25
	Impervious soils and waterlogged areas 50	

From each of the three columns the most appropriate value should be selected, and the values should be added to give the numerical figure for these characteristics.

Now the runoff in cusecs can be read from a table using: a) the runoff area in acres and b) the characteristics. Dependent on the shape of the runoff area one of three tables should be used: 1) square (p. 58), 2) broad and short (p. 59) or 3) long and narrow area (p. 60).

The differences between different shapes can be seen from the drawings below. The figures represent the runoff in cusecs from 5 acres with summarized numerical characteristics of 80:

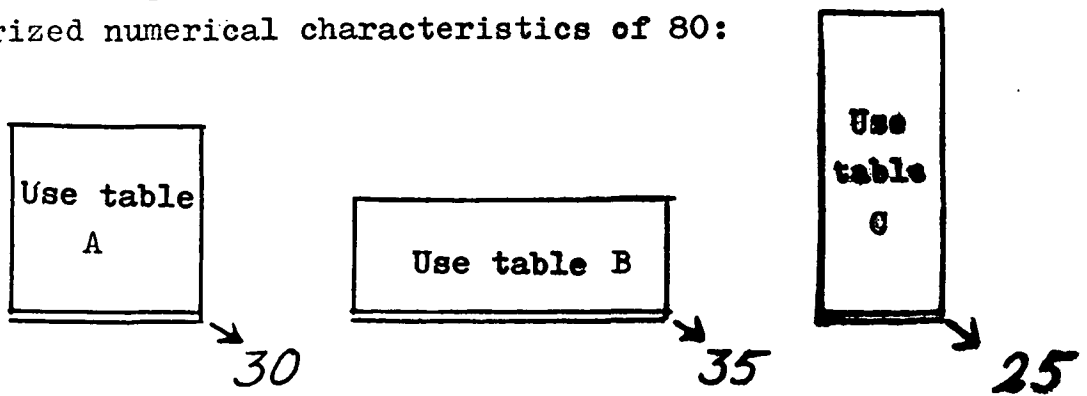

**Table A. Runoff in cusecs from a square runoff area  
(more or less square)**

Runoff area in acres	Summarized characteristics of the runoff area											
	25	30	35	40	45	50	55	60	65	70	75	80
5	3	5	7	9	11	13	15	17	19	21	25	30
10	5	8	11	14	17	21	25	30	35	40	46	52
15	7	11	15	20	25	30	35	42	50	58	66	75
20	10	15	20	25	30	38	46	55	65	75	85	95
30	12	18	25	33	42	52	64	76	90	105	120	135
40	15	20	30	40	50	65	80	95	110	130	150	175
50	17	25	35	50	65	80	100	120	140	165	190	215
75	20	35	50	70	90	115	140	170	200	235	270	310
100	25	45	65	90	120	150	180	220	260	300	350	400
150	35	60	90	125	165	210	260	310	365	425	500	580
200	40	80	120	170	220	270	330	400	470	550	640	750
250	50	90	140	190	245	310	385	470	565	670	785	910
300	60	100	150	210	280	360	450	550	660	780	910	1050
350	70	120	180	240	330	430	540	640	760	890	1030	1160
400	80	140	200	280	370	490	600	710	860	990	1160	1280
450	90	150	220	300	410	540	660	780	940	1090	1280	1390
500	100	160	240	330	450	590	720	850	1030	1200	1390	1520

**Example: A hillside in Machakos District**

First estimate the width and the length of the runoff area, e.g. width 200 m and length 200 m, giving an area of 40,000 sq.m, to be divided by 4,000 sq.m (= 1 acre) to get the area in acres =  $\frac{40,000}{4,000} = 10$  acres.

After that find out the characteristics:

- 1) scrub and grass      15
- 2) shallow soil        30
- 3) steep slopes        20

summarized 65

Now read off from the table above:

- a) Runoff area in acres            10
  - b) Summarized characteristics    65
- giving a runoff of 35 cusecs.

Table B. Runoff in cusecs from a broad and short runoff area  
(more or less rectangular and along the contour)

Runoff area in acres	Summarized characteristics of the runoff area											
	25	30	35	40	45	50	55	60	65	70	75	80
5	4	6	8	10	12	15	18	21	24	27	31	35
10	7	10	12	15	20	26	32	38	44	51	58	65
15	9	14	19	25	32	40	48	57	66	75	85	95
20	12	18	25	32	40	50	60	70	80	95	110	125
30	16	25	35	45	55	70	85	100	115	135	155	175
40	19	30	42	55	70	90	110	130	150	175	200	225
50	23	35	50	65	85	110	135	160	185	210	240	275
75	30	50	70	95	120	150	185	220	255	295	340	390
100	35	60	85	120	160	205	250	295	345	395	450	510
150	45	85	125	170	220	280	340	410	485	560	640	725
200	55	100	150	205	280	360	445	535	630	730	830	935
250	65	125	190	260	340	440	550	665	780	900	1020	1145
300	80	145	220	300	390	490	600	720	850	990	1150	1350
350	100	170	260	340	460	580	700	830	980	1160	1340	1510
400	110	210	290	400	520	670	800	920	1120	1300	1500	1660
450	120	220	320	440	580	740	880	1020	1240	1420	1670	1810
500	130	230	340	470	630	800	960	1110	1350	1560	1800	1970

Example: Width 500 m and length 200 m,  
giving an area of 100,000 sq.m = 25 acres.  
The same characteristics as on p. 58 = 65.  
Now read off from the table above:  
The runoff area in acres is 25 (i.e. between 20  
and 30 in the table).  
Summarized characteristics = 65.  
The runoff for 20 acres will be 80 cusecs, and  
for 30 acres 115 cusecs.  
Thus  $\frac{20 + 30}{2} = 25$  acres and  $\frac{80 + 115}{2} = \underline{98}$  cusecs.

Table C. Runoff in cusecs from a long and narrow runoff area (more or less rectangular along the slope, which is the most common shape of a small farm)

Runoff area in acres	Summarized characteristics of the runoff area											
	25	30	35	40	45	50	55	60	65	70	75	80
5	3	4	5	6	8	10	12	14	16	19	22	25
10	4	6	9	12	15	18	22	26	30	35	40	45
15	6	9	12	16	20	25	30	35	41	47	53	60
20	7	11	16	21	27	33	39	46	54	62	70	80
30	9	15	21	28	36	46	56	66	76	88	100	115
40	12	20	28	36	46	58	70	85	100	115	130	145
50	15	25	35	45	60	75	90	105	120	135	155	175
75	20	32	45	60	80	100	120	145	170	195	225	255
100	25	40	55	75	100	130	160	190	220	255	290	330
150	32	55	80	105	140	180	225	270	315	360	410	470
200	40	70	100	135	180	235	290	345	405	470	540	615
250	45	80	120	160	215	280	345	415	490	570	660	760
300	50	90	135	190	250	320	400	480	570	670	780	900
350	60	100	150	200	280	370	470	550	660	770	890	1000
400	70	120	170	240	330	420	520	610	740	860	1000	1100
450	80	130	190	260	360	470	570	670	820	940	1100	1200
500	90	140	200	280	390	510	620	740	890	1040	1200	1320

Notes

1 cusec (cubic foot per second) = 28.3 litres/sec.

If the runoff area in the first column of the tables is read in hectares instead of in acres and if the figures for the runoff in cusecs are divided by 0.07, the runoff values of the tables will show cubic metres per second instead of cusecs.

The tables are computed for a period of 10 years, which is the period usually used for the design of soil conservation works. For shorter or longer periods the following conversion factors should be used:

2 years	0.90	10 years	1.00	25 years	1.25
5 years	0.95			50 years	1.50

The tables on pages 58-60 are from Norman Hudson's textbook "Soil conservation", 1971.



2. How to find the cross-sectional dimensions of cutoff drains by use of four tables and two calculations (Durbach's method)

1. A table for finding the maximum velocity of water flow in ft/sec (the fastest water flow without erosion) from: a) the soil type and b) the degree of grass cover in the channel (expected after 2 years):

Table 1

Soil type	Grass cover expected in the channel		
	Sparse cover (suggested for dry areas)	Medium cover (for normal use)	Very good cover (suggested for highlands)
Silty sand	1.0	2.5	4.5
Sand	1.5	3.0	5.0
Coarse sand	2.5	4.0	5.5
Sandy soil	2.5	4.5	6.5
Loam	3.0	5.0	7.0
Clay loam	3.5	5.5	7.5
Clay	4.5	6.0	8.0
Gravel	5.0	6.0	
Soft rock, hardpan	6.0	7.0	

2. A table for finding the channel factor ( $= V \times \sqrt{\frac{L}{H}}$ ) from: a) the gradient of the channel expressed in Height:Length or in % slope, and b) the maximum velocity in feet/second found in table 1 above:

Table 2

Gradient			Maximum velocity in feet/sec								
Height:Length	=	%	1.0	1.5	2.0	3.0	4.0	5.0	6.0	7.0	8.0
1:50	=	2.0	-	-	14	21	28	35	42	50	57
1:100	=	1.0	-	15	20	30	40	50	60	70	80
1:200	=	0.5	14	21	28	42	56	71	85	99	113
1:400	=	0.25	20	30	40	60	80	100	-	-	-

3. A table for finding the depth of the channel using the channel factor found in table 2:

Table 3

Channel factor from table 2	Depth of the channel in feet	
20	0.25	} in view of the risk of silting up if possible not less than 1 foot
32	0.50	
42	0.75	
50	1.00	
58	1.25	
65	1.50	
72	1.75	
79	2.00	
86	2.25	
92	2.50	
98	2.75	
104	3.00	

4. A table for finding the discharge (in cusecs per foot width of channel) from a) the depth of the channel (in feet) and b) the channel gradient (as a percentage):

Table 4

Depth of channel in feet	Gradient as %			
	2.0	1.0	0.5	0.25
0.25	1.0	0.7	0.5	0.3
0.5	3.1	2.2	1.6	1.1
0.75	6.0	4.3	3.0	2.2
1.0	9.7	6.8	4.8	3.4
1.25	13	10	7.0	5.0
1.5	16	13	9.5	6.7
1.75	19	17	12	8.6
2.0	21	21	16	11
2.25	24	24	19	13
2.5	27	27	23	16
2.75	29	29	26	18
3.0	32	32	32	22

5. The width of the channel in feet (of trapezoid or parabolic section) can be calculated by dividing the runoff (in cusecs) by the discharge figure arrived at from table 4. For a rectangular section reduce the width by  $1/3$  as shown in the figure on page 63.

### 3. Example of a calculation

The soil is clay loam and the grass cover of the cutoff channel is not expected to be very good.

According to Table 1 the maximum velocity of the water flow will be 5.5 feet/sec.

The gradient of the channel is 0.5%. As the maximum velocity is 5.5 feet/sec, the channel factor will be between 71 and 85 according to Table 2 =  $\frac{71+85}{2} = 78$ .

As the channel factor of 78 is the closest figure to 79 in the first column of Table 3, the depth of the channel should be read as 2 feet in the right hand column of Table 3.

In Table 4 a channel depth of 2 feet and a gradient of 0.5 % gives a discharge of 16 cusecs per foot width of channel.

The catchment area is estimated to be 500 m wide across the slope and 200 m long down the slope, i.e. 100,000 square metres. By dividing this figure by 4,000 square metres (= 1 acre) it gives a runoff area of 25 acres.

The hillside above the cutoff drain consists of scrub with some grass (value for vegetative cover = 15 according to the table on p.57). The soil is a shallow clay loam (value for infiltration rate = 30). The hillside is steep (value for slope = 20). The summarized characteristics:  $15 + 30 + 20 = 65$ .

As the runoff area is broad and short; Table B on p. 59 should be used. An area of 25 acres and summarized numerical characteristics of 65 give a runoff of  $\frac{80 + 115}{2} = 98$  cusecs.

The width of the channel in feet is obtained by dividing the runoff (= 98) by the discharge (= 16 according to p.59):  $\frac{98}{16} = 6$  feet.

Result: The size of the cutoff drain will be 2 feet (0.6 m) deep and 6 feet (1.8 m) wide.

If a rectangular cross-section is desired, perhaps simpler to dig by hand, the width will be  $\frac{2 \times 6}{3} = 4$  feet (1.2 m).

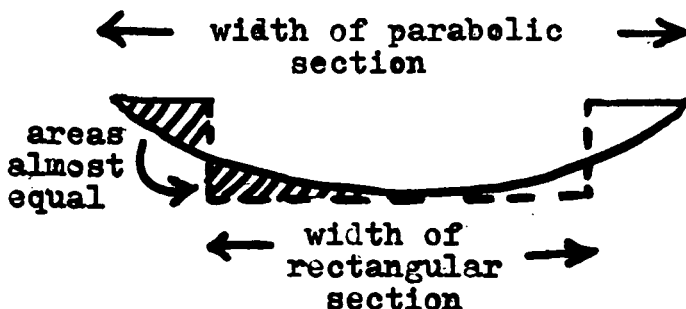

4. Summary of how to find out the size of a cutoff drain

I. Calculate the amount of water (runoff) from the runoff area

1) Size of runoff area:

a) width (along the contour) in metres =

b) length (down the slope) in metres =

Area in sq m: width x length =

Area in acres:  $\frac{\text{area}}{4,000} =$

2) Summarize the characteristics of the runoff area (p.57):

a) vegetation =

b) soil =

c) topography =

Summarized =

3) Read from one of 3 tables (p. 58, 59, 60):

Use table  
A  
p. 58

Use table B  
p. 59

Use  
table  
C  
p. 60

to find the runoff in cu.secs =

II. Select the gradient of the channel as a percentage (0.5 or 0.25 %)

III. Read from four tables (p.61 - 62):

1) Table 1, maximum velocity =

2) Table 2, channel factor =

3) Table 3, depth in feet =

4) Table 4, discharge =

IV. Make two calculations to find the width (p. 62 and 63):

1) Width in feet =  $\frac{\text{Runoff (I 3 above)}}{\text{Discharge (III 4 above)}} =$

2) Reduced width in feet for a rectangular cross section

$\frac{2 \times W}{3} =$

**5. Questions**

- 1. Calculate the cross-section dimensions of a cutoff drain, if the runoff area has a width of 400 m and a length of 200 m.**

**Local characteristics of the runoff area: sparse vegetation cover, rocky ground, slope 20-30 %. The soil is clay loam. The gradient of the channel is assumed to be 0.5 %, and the grass cover is expected to be medium.**

- 2. In this example the runoff area is 300 x 300 m. Local characteristics: grass land, clay, slope 10 %. The place is Ngong northwest of Nairobi,**

**For comparison calculate the cross-section dimensions of a cutoff drain using both methods (p. 54 and p. 57).**

### Vegetation Cover

Maize must not be planted on the embankment or in the channel. The channel and the embankment should be covered by low natural vegetation, or be planted with grass, in the channel, preferably some low-growing species, e.g. Kikuyu grass. A more productive grass could be planted on the embankments, e.g. napier grass or bana grass. Sometimes sweet potatoes or sugar cane or pigeon peas are planted on the embankments.

It is recommended that bushes or fruit trees or timber trees be planted on the top or on the slope of the embankment. Bananas can be planted along the foot of the embankment, and sugar cane on the slope above the bananas. For bushes I have seen bixa and Finger euphorbia in combination with napier grass. Suitable fruit trees are for example oranges and peaches and suitable timber trees for example Grevillea robusta and Hakea saligna.

### Gradient

Cutoff drains must always be graded. The gradient (or "grade") is the slope of the channel in longitudinal direction of the channel. It can be constant along the channel or can be varied, but to simplify the layout work the same gradient is normally used along the whole length of the channel line.

In principle the gradient should be steep enough to remove sediment brought down from the slope above, but flat enough to prevent erosion.

The gradient of the cutoff drain in the longitudinal direction of the channel is usually 0.25 - 0.5 %. A small gradient on 0.25 % is used in erodible silty - sandy soils, and a large gradient of 0.5 % in clay and loam. If these figures are used for layout with line level, the gradient might vary between 0 and 0.5 % in loam and silty-sandy soils and between 0.25 and 0.75 % in clay and clay loam.

Sometimes the deviations will be larger. For the layout of long cutoff drains quickset levels are therefore preferable to line levels, but quick set levels are not always available. In both cases the gradient of the bottom of the dug channel should be checked, so that the gradient is correct without high spots.

Length

To minimize the risks of flooding, the cutoff drains should be as short as possible. Short cutoff drains are also easier to maintain. A maximum length of 600 m was earlier recommended, but experience from tropical Africa has shown that shorter lengths are better, especially in erodible soils:

	clay soils	other soils
normal length	400 m	200 m
maximum length	450 m	450 m

If it is difficult to find a suitable outlet point within 450 m, the maximum length recommended above may be much longer.

Digging

The digging of a cutoff drain should start from the outlet point, because rock or large boulders can hinder further digging. If there are depressions along the cutoff drain, e.g. from channels crossing the cutoff drain, these depressions should be filled up with soil well compacted layer by layer.

The side walls should usually have a slope, but it is often best to start digging a channel with vertical walls (fig. b below) which later can be given the necessary slope to become stable (fig. c):

Fig. a  
Required cross-section

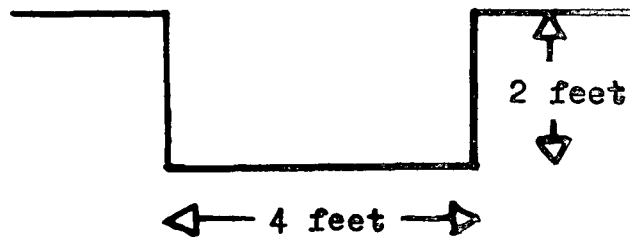

Fig. b  
First digging

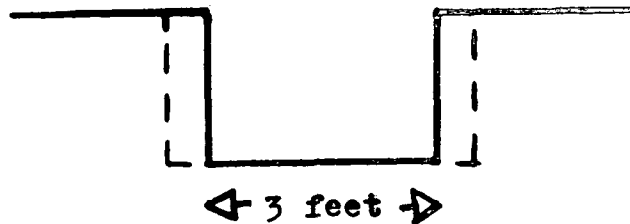
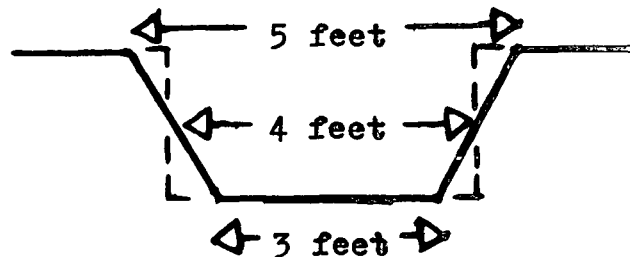

Fig. c  
Final cross-section



The inclination of the side wall is said to be 1 : 2 in this case, i.e. 1 foot horizontally with a depth of 2 feet.

Costs

The digging work should be paid on a piece work basis, i.e. per excavated channel volume. The cost per m length of channel varies with the type of soil and with the size of the cross-section. It is for example more difficult and more expensive to dig in clay than in sand. In the table below there are examples of standard cross-sections, showing the number of m in length that 1 cu.m of the different sections represents and the cost in Shs/m.

Calculation example:

Depth 0.6 m x width 0.6 m gives a cross-section area of 0.36 sq.m. One cu.m of excavated soil of this cross-section corresponds to a length of: 1 cu.m divided by 0.36 sq.m = 2.77 m. If the digging cost is 1.75 Shs/cu.m the digging cost per m will be 1.75 Shs/cu.m divided by 2.77 = 0.63 Shs/m.

Cross-section			Length of 1 cu.m in m	Cost Shs/m for different digging costs per volume (Shs/cu.m)				
Depth m	Width m	Area sq.m		1.75 shs/cu.m	2.00 shs/cu.m	2.25 shs/cu.m	2.50 shs/cu.m	
0.6	0.6	0.36	2.77	0.65	0.70	0.80	0.90	) around
0.6	0.9	0.54	1.85	0.95	1.10	1.20	1.35	) 1 sh/m
0.6	1.2	0.72	1.39	1.25	1.45	1.60	1.80	) around
0.6	1.5	0.90	1.11	1.60	1.80	2.05	2.25	) 2 shs/

Difficult bush clearing, removal of coffee trees from the channel, etc. might increase the cost. Such extra costs should be specified as Miscellaneous costs for labour and should not be included in the Digging costs Shs/cu.m and Shs/m.

Maintenance

Every year the sediments in the cutoff drain and especially high points of sediment should be removed to maintain the gradient. The downhill ridge should also be maintained. If these rules are not followed, the cutoff drain can flood over the ridge and cause a lot of erosion, sometimes more erosion than without any cutoff drain at all.

Those farmers, who have land below a cutoff drain and thus have the benefit of the cutoff drain, should form a maintenance group, to be organized by the technical staff (using the form on the next page). Instructions for filling up the Maintenance Form are given on p.68 .



MAINTENANCE FORM FOR CUTOFF DRAIN

SITE

Division:  
Location:  
Sublocation:

DIMENSIONS OF CUTOFF DRAIN

Length m:  
Depth m:  
Width at top m:            at bottom m:  
   average width m:  
Area of excavated cross-section sq.m:  
Total volume cu.m:

WORK

Date of start:  
Date of finishing:  
Number of workers:  
Number of man days  
    for digging work:  
    for miscellaneous:  
Cu.m dug per man day:  
Soil type:  
Daily payment per worker Shs/day:

COSTS

Cost of digging work Shs:  
    of miscellaneous work Shs:  
Total cost of the cutoff drain Shs:  
Digging cost calculated as  
    Shs/ m length of the cutoff drain:  
    Shs/cu.m of the cutoff drain:

SKETCH MAP OF THE FARMS WHICH BENEFIT FROM THE CUTOFF DRAIN

NAMES OF THE FARMERS OF THE MAINTENANCE GROUP (No. 1 = the Chairman)

- |         |          |
|---------|----------|
| 1 ..... | 6 .....  |
| 2 ..... | 7 .....  |
| 3 ..... | 8 .....  |
| 4 ..... | 9 .....  |
| 5 ..... | 10 ..... |

REMARKS This form has to be completed in 6 copies, of which No. 1 should be distributed to the DAO, No. 2 kept by the assistant and later given to the TO of the division, No. 3 to the Chairman of the maintenance group, No. 4 to the DO, No. 5 to the Chief and No. 6 to the Sub-chief. It is the responsibility of the Sub-chief to make sure that the members of the group set aside 1 - 3 days every year after the long rains for cleaning the cutoff channel.

Instructions for filling up the Maintenance Form

Cross-section = depth x width  
Volume = length x cross-section  
Length = volume ÷ cross-section

Examples of technical data

DIMENSIONS OF CUTOFF DRAIN

Length 200 m  
Depth 0.6 m  
Width at top 1.4 m, at bottom 1.0 m, average 1.2 m  
Area of cross-section  $1.2 \times 0.6 = 0.72 \text{ sq.m}$   
Total volume  $200 \text{ m} \times 0.72 \text{ sq.m} = \underline{144 \text{ cu.m}}$

COSTS

Cost of digging work 360 shs  
miscellaneous 40 shs  
Total cost of cutoff drain 400 shs

Digging cost calculated as

$\text{shs/m length of cutoff drain } 360 \text{ shs} \div 200 \text{ m} = \underline{1.80 \text{ shs/m}}$   
 $\text{shs/cu.m of the cutoff drain } 360 \text{ shs} \div 144 \text{ cu.m} = \underline{2.50 \text{ shs/cu.m}}$

WORK

Date of start 20/9  
Date of finishing 24/9 = 5 days  
Number of workers 10  
Number of man days  
for digging work  $5 \times 10 = 50 \text{ man days}$   
for miscellaneous work  $40 \text{ shs} \div \text{daily rate } 6.75 \text{ shs/day} = 6 \text{ man}$   
Cu.m dug per man day  $144 \text{ cu.m} \div 50 \text{ man days} = 2.88 \text{ cu.m/man day}$   
Soil is loam.  
Daily payment per worker in shs/day for digging work  
 $360 \text{ shs} \div 50 \text{ man days} = \underline{7.20 \text{ shs/day}}$

Example of sketch map

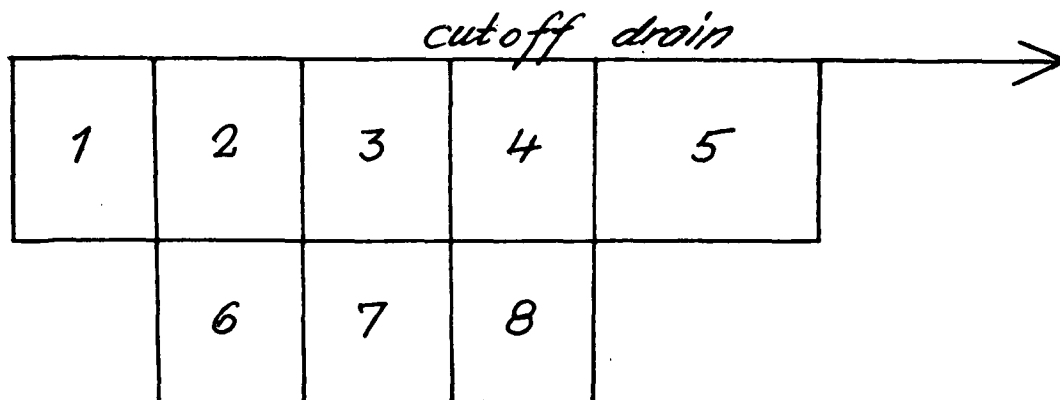

After the long rains each year the farmers should set aside one or more days for cleaning the channel of sediment. The sub-chief should control this work so that maintenance is done every year thus preventing the cutoff drain from being filled up with sediment and becoming unusable.

The form should be completed in 6 copies and copies distributed to:

- |                                      |              |
|--------------------------------------|--------------|
| 1) DAO's office                      | 4) DO        |
| 2) TO of the division                | 5) Chief     |
| 3) Chairman of the maintenance group | 6) Sub-chief |

If a footpath crosses a drain, some logs should be laid over the channel as a bridge. To prevent the embankment, at the approach to the bridge, from being lowered by the trampling of people and cattle, some stones or wood should be laid as paving. If this procedure is not followed, a break can be caused in the embankment, particularly in flood periods.

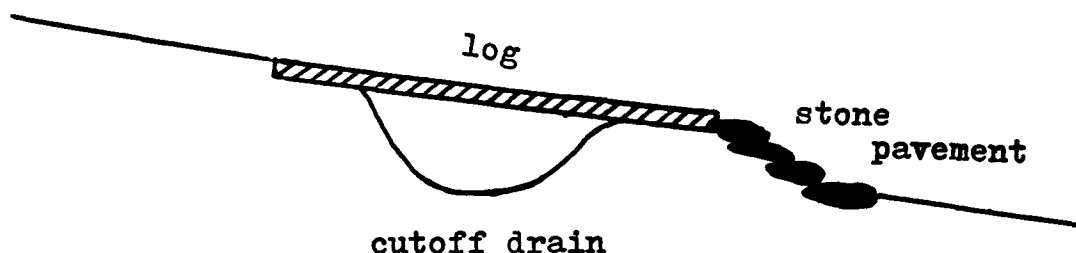

#### SPECIFIC DIVERSION DITCHES

In the tea fields, normally situated on slopes, the critical period for erosion is the establishment of the tea bushes (3 - 5 years). According to trials in Kericho District the annual soil losses in tons/ha on a 10 % slope were:

Year	No soil conservation	Inter rows of oats	Inter rows of mulch
1	161	35	0.5
2	42	4	0.14
3	1	0.4	0.08

After 3 - 5 years the tea bushes cover the soil completely, absorb rain water and minimize raindrop erosion. Pruning litter and dead leaves on the ground reduce rill erosion. However, on steep slopes it may be necessary to divert the overland flow by diversion ditches (= channel terraces = small cutoff drains). For example, in Kirinyaga District I have seen diversion ditches at intervals of 12 metres (20 rows of bushes) in a tea field on a slope of 35 %.

Questions on the figures in the maintenance form

1. Work started 21/9 and finished 30/9.  
Numbers of workers for digging work 10.  
Length of the cutoff drain 400 m.  
Depth 0.6 m.  
Width at the top 0.9 m, at the bottom 0.6 m.  
Total cost of the digging work Shs 450.
  - 1 a) How many cu.m per man day ?
  - 1 b) Total wolume dug in cu.m ?
  - 1 c) Digging costs calculated as Shs/m and Shs/cu.m ?
  
2. Work started 21/9 and finished 23/9.  
Number of workers for digging work 5.  
Length of the cutoff drain 100 m.  
Depth 0.6 m.  
Width at the top 1.5 m, at the bottom 0.9 m.  
Digging cost 2 Shs/cu.m.
  - 2 a) Cu.m dug per man day ?
  - 2 b) Total cost of the cutoff drain ?
  - 2 c) Digging cost Shs/m ?
  
3. A cutoff drain has a top width of 1.5 m, a bottom width of 0.9 m and a depth of 0.6 m. How many metres of this cutoff drain should a daily labourer dig per day ? It is supposed that the soil is normal (a digging rate of 3 cu.m/day).

## ARTIFICIAL WATERWAYS

### What is an artificial waterway ?

In soil conservation artificial waterways usually mean wide and shallow drainage ways down a slope not exceeding 25%. As to steeper slopes check dams can be used as preventive measure (see chapter 1, p.10 and Appendix 1, p.4-10).

### Need for artificial waterways

Unless it is possible to discharge the water from cutoff drains and terraces into natural watercourses or into non-erodible areas, construction of artificial waterways leading to rivers or to non-erodible areas, will be necessary.

It is no exaggeration to say that the necessary artificial waterways have usually been neglected by farmers and agricultural staff in Kenya. Water is often discharged onto foot paths and farm roads. This can be disastrous, especially if new cutoff drains are not discharged into suitable areas. In such cases gully erosion can start and develop, seriously damaging cultivated land.

### Siting

Usually it is best to use the boundary between two farms as an artificial waterway. As the width needed for a waterway is rather large, the "Loss of land" for the waterway will be divided between the two farms, which will have the benefit of the waterway. There are frequently bushes of little value along the boundaries as well as weeds and grass, so that the waterway will often not cause hardship to the farmers.

If there are several boundaries the one selected should have the smallest gradient. In soils of clay and clay loam it might be possible to have grassed waterways up to a slope of about 25 %. When siting the artificial waterway the discharge point (outlet) should be selected in such a way, that the risk of erosion will be as small as possible.

If it is difficult to find a good site for an artificial waterway or if the waterway is very long with a risk of erosion, it may be better and perhaps cheaper to dig a long cutoff drain.

### Cross-section

The water must not be concentrated in a deep furrow.

The cross-section of an artificial waterway should be wide and shallow to distribute the flow and minimize erosion.

The cross-section can be constructed in two ways (Fig.5a and b on p.72), or be a combination of both ways (see Fig. 5 c on p.72).

- Fig. a) excavated parabolic cross-section
- Fig. b) embankments on both sides of a waterway with more or less undisturbed ground surface
- Fig. c) the excavated soil used in the construction of embankments (combination of a and b).

A waterway should usually be at least 1.5 m (5 feet) wide and 0.3 m (1 foot) deep. In the following passage width and depth are treated in separate paragraphs.

Width of waterways. -

A waterway usually receives water from both sides. In the table below (from J.M. Hall: A Handbook on Basic conservation, Malawi 1976) the width of the waterway is estimated regarding runoff area and the steepness of the slope. For runoff areas up to 4 acres the width is about 5 feet. For runoff areas with steep slopes and larger than 4 acres, the rule of thumb is 1 foot width for every acre of catchment.

Runoff area of the waterway in acres	Width of waterway in feet		
	on slope of 0-5 %	on slope of 6-12 %	on slope of 13-25 %
1	5	5	5
2	5	5	5
3	5	5	6
4	5	6	7
5	5	6	8
10	6	8	10
15	7	11	17
20	8	15	23
25	9	19	28
30	9	23	34
35	11	26	39
40	12	30	44
45	14	34	50
50	16	38	56

The width might be reduced to half of the figures above, if 1/3 of the waterways is well paved with stones.



Cross-sections of  
artificial waterways

Fig. 5

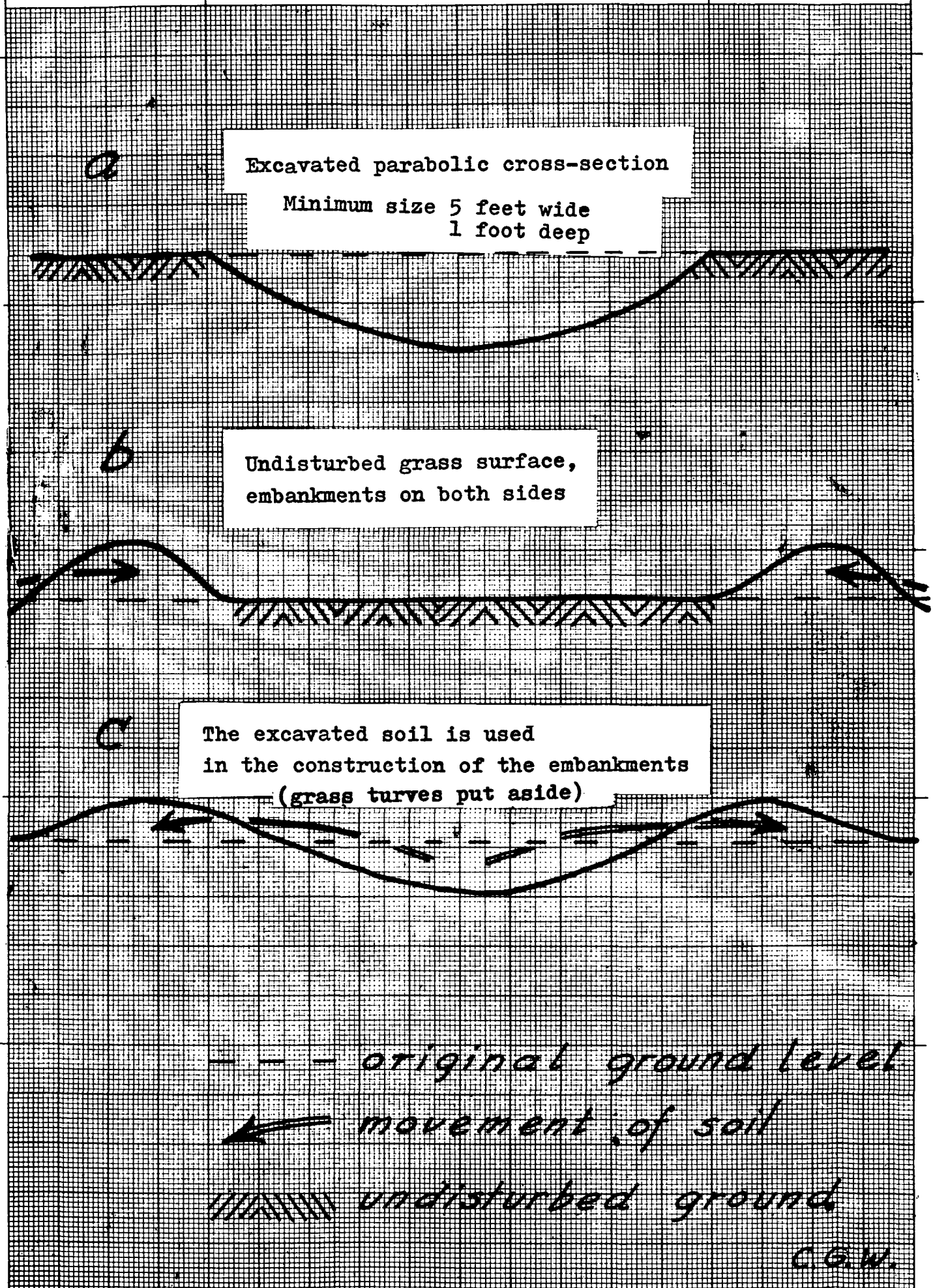

The table on p.71 does not take into account the erodibility of different soils. As the table is valid for high water flow velocities (up to 5 - 6 feet per second), a smaller width could probably be used in soils of clay and clay loam. Anyhow it will be difficult to convince farmers who own only a few acres of land to use more than 0.75 m (half the width of 1.5 m or 5 feet) for a waterway. Considering this, it may often be best to construct a waterway along every second common boundary, i.e. two farms share one waterway. In Kenya small-scale farmers often prefer to use a narrow waterway with check dams, similar to those used in gully control, instead of a wide channel (p. 9 - 10).

Depth of waterways.-

The depth of a waterway is related to the width in the following way:

<u>Width</u>	<u>Depth</u>
up to 10 feet	1 foot
10 - 20 feet	1½ feet
more than 20 feet	1½ feet

Grass cover

The waterway should have a cover of short but thick grass to prevent erosion. It must not be used as a path for people or cattle.

Usually it will take up to 2 years to establish a good grass cover, and during the 2 year period the waterway will be very sensitive to erosion. Therefore channels and terraces discharging into the waterway should, if possible, be blocked up during the 2 year period, i.e. a strip of the ground between the ends of the channel and the waterway should remain unexcavated. It is of course best to construct the artificial waterways first, and cutoffs and terraces 2 years later, but this is not always possible.

If there is grass growing along the boundary where the waterway will be excavated, the turves should be put aside at the start and replaced in the the waterway after the excavation work is finished. Such a measure will reduce the risks of erosion during the first two years.

Kikuyu grass has been introduced into many countries to protect the soil against erosion by water flows. In the depressions of waterways the ground is wetter than on the sides, which assists the Kikuyu grass in establishing itself for the protection of the waterways. But even in dry areas (e.g. in certain areas of Australia with an annual rainfall of only 500 - 600 mm) this grass has been used for this particular purpose.

Planting material of Kikuyu grass will give a cover faster than by planting seeds. When planting, stems with 3 - 4 nodes should be laid in furrows, 5 - 7 cm deep, refilled with compacted soil.



If seeded, the planting depth should be between 1 and 5 cm, usually 2 - 3 cm, the depth depending on the availability of soil moisture. The seeding rate is 0.5 - 5 kg/ha, usually 2 kg/ha.

Kikuyu grass needs a fertile soil, and topdressing with nitrogen during the first year is strongly recommended.

Kikuyu grass can have difficulty in establishing itself in clay soil, where the runners of the grass remain above the ground, and subsequently wither and die without forming any protective cover.

The lock and step drain - a special type of waterway

In the table p. 71, figures are given for waterways on slopes of up to 25 %. This may be possible in cohesive non erodible soils. However, in some loams of about 20 % slope the waterway has to be stepped with sodded earth bunds as can be seen from the figs. below. The idea is that the effect of the "waterfalls" is minimized by "cushions" of water. The construction appears to be expensive, but may sometimes be necessary. The lock and step drain has been used with success in Sri Lanka (see the figures below).

*Section down slope*

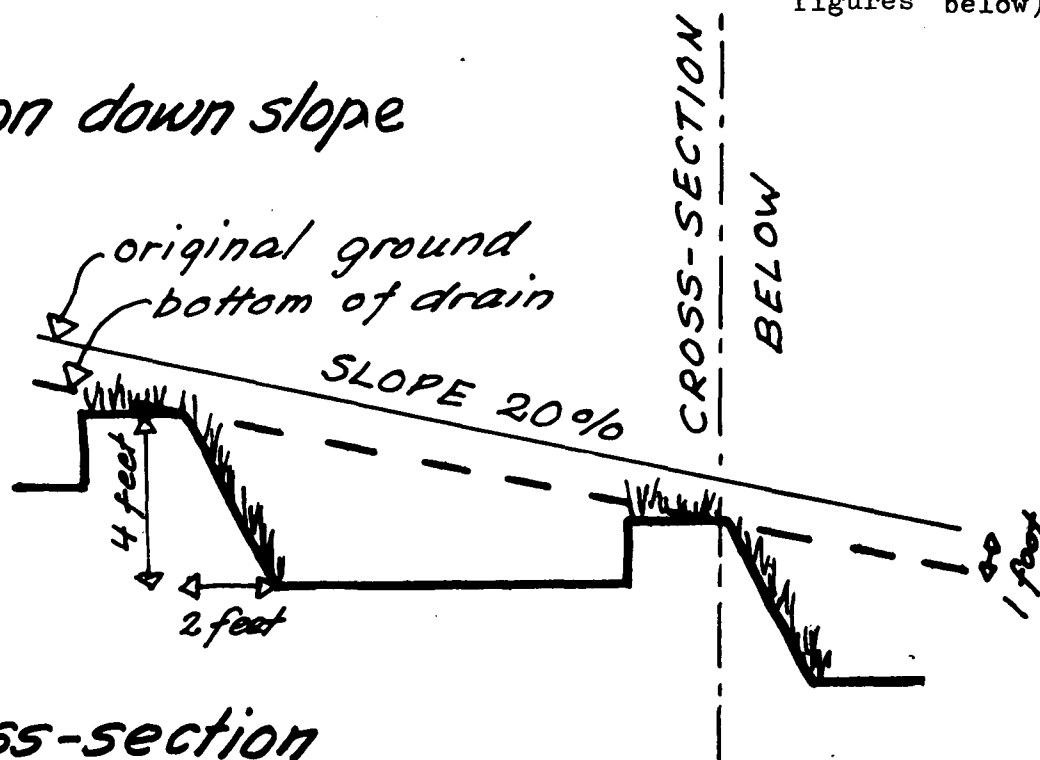

*Cross-section*

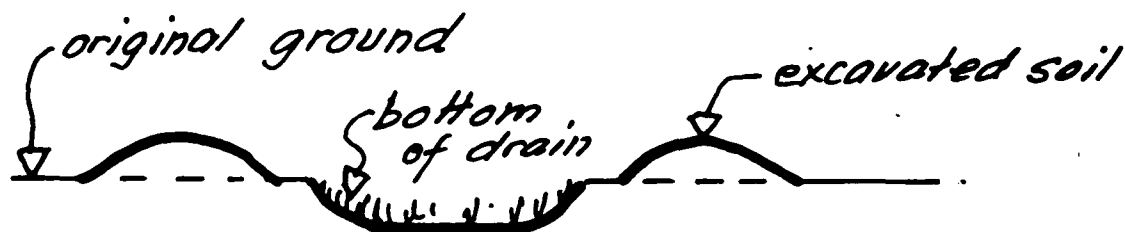

(Drawn after V. A. Beckley)

TERRACES

What is a terrace ?

In everyday language a terrace means a level piece of ground on a slope, but from American soil conservation a wider meaning of the concept of a terrace has been introduced. Thus a "terrace" can also be a hillside ditch or a ridge for controlling the flow of surface water down a slope. Cutoff drains (diversion ditches) and artificial waterways have not been included in the concept of terraces in this paper, but have been treated separately in the two previous chapters.

Need for terraces

Terraces are needed on slopes with erodible soils, where contour farming, crop rotation and/or strip cropping by themselves are not sufficient measures to prevent an undesirable loss of soil.

Types of terraces

Terraces can be made either mechanically or by hand, but it is not economic to use machines on slopes of more than 12 - 15 %. There is no sharp limit between when to use machines and when hand work. The potential for mechanized soil conservation work decreases by 30 - 60 %, when the slope increases from 5 to 10%. On steep slopes of more than 15 - 20 %, there is a risk of a tractor turning over.

Given below and in Fig. 6 on the next page are the different types of terraces. Figures in brackets represent upper slope limits possible under certain conditions.

1. Bench terraces

slope 2(12) - 35(55) %

a) Excavated type:

Ordinary Modified  
slope 12(20)-35 % slope 35-55 %

b) Developed type:

Grass strip Fanya Juu method  
slope 2 - 35 (55) % slope 2 - 55 %

2. Channel terraces

slope 5(8) - 12(20) %

a) Narrow-base type, not cultivated  
up to 20 % slope

b) Broad-base type, cultivated  
up to 12 % slope

3 Ridge terraces

slope 2 - 5(8) %

a) Narrow-base type, not cultivated  
up to 4 m wide

b) Broad-base type, cultivated  
up to 16 m wide

# 1 BENCH TERRACES

## a) EXCAVATED TYPES

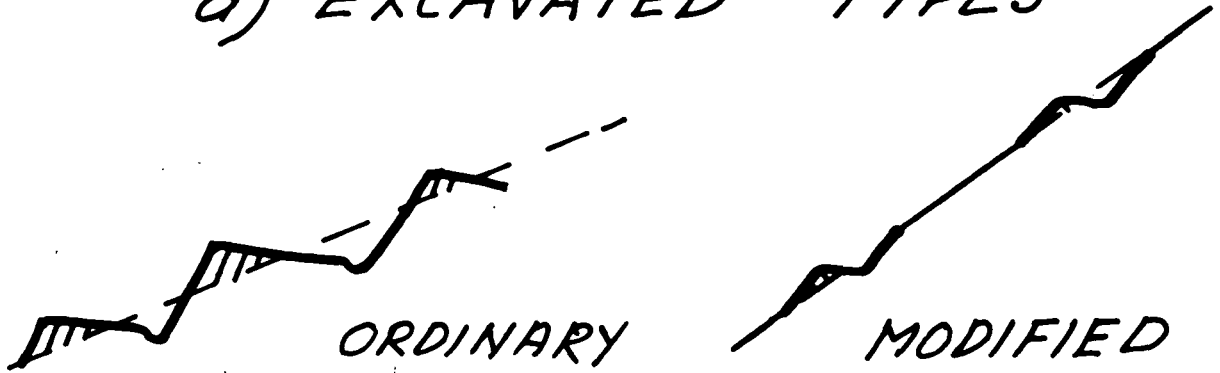

## b) DEVELOPED TYPES

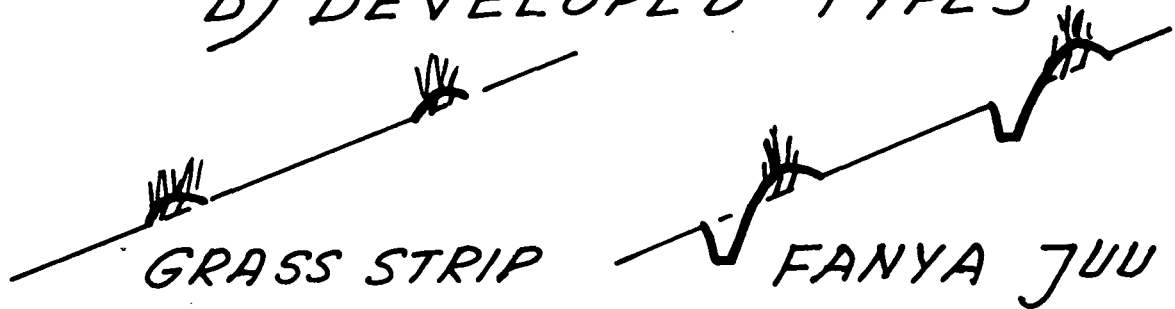

# 2 CHANNEL TERRACES

## a) NARROW-BASE      b) BROAD-BASE (NICHOLS TERRACE)



# 3 RIDGE TERRACES

## a) NARROW-BASE      b) BROAD-BASE (MANGUM TERRACE)



Bench terraces are not practicable in shallow soils (less than 0.5 - 0.8 m ).

The excavated type of bench terrace is not used much any more, because it represents an enormous quantity of digging work and because infertile subsoil will be brought up to the surface unless special measures are taken (p.88b - 90). However, on steep slopes of 25 - 55% the excavated bench terrace can be modified to only narrow ledges, especially suitable for fruit trees.

The bench terrace best suitable to Kenyan conditions is the developed type, either starting with a grass strip, or with the formation of a bench from the Fanya Juu method.

The other two main types of terraces are the channel terrace and the ridge terrace.

In the construction of a channel terrace, the soil is moved downhill. The maximum slope for a channel terrace is 15 - 20%.

On gentle slopes of less than 5 - 8% it is difficult to form a ridge from only one side. Therefore soil is moved from both sides of the ridge, forming a ridge terrace.

If the ridge is made wide and low, and the channel wide and shallow, tractors can pass over the ridges and channels, which can thus be cultivated in the same way as other parts of the field. Such a tillable terrace is called broad-base (or broad-based), as opposed to the narrow-base (or narrow-based) type of terrace. It is convenient to use level broad-base ridge terraces in dry areas, where water holding is important. However, broad-base terraces are of little interest in small-scale farming and are not used on slopes exceeding 12%.

Previously terracing was usually done as ditches (channel terraces) with distances between terraces varying according to a formula. The function of these channels has been to drain the rain water flows of the shamba, and to decrease the length of the flow down the slope, thus reducing soil erosion and preventing the formation of gullies. However, as 70% of the soil disturbed by rain erosion is moved downhill, it will be collected by the channels and transported by the water. This action causes water pollution and silting up of water reservoirs, at the same time filling up the channels with sediment, needing annual maintenance. In most cases, however, the maintenance of the channels is neglected by the farmers, so the channels are silted up. The grass of the channel has then turned into a grass strip. So the farmer asks himself, why did I not start with a grass strip. Consequently farmers have realized that the best method of conserving the soil is

to use grass strips or bench terraces (the "converse" terracing method) rather than by any of the other methods. The channel terrace of course should be used if drainage is needed. The various types of terraces suitable for small-scale farming will be treated in more detail in later paragraphs of this chapter.

### Siting

Any intensified soil conservation should consider previous terraces and should, as much as possible, be adapted to existing terraces or remnants of terraces. If no previous terracing exists, the following should be considered.

The first thing to consider is how to discharge the water from the terraces. For this, suitable outlets are the same as those for cutoff drains, i.e. existing natural water courses, permanent pasture or forest, and stony or rocky ground. If these possibilities do not exist, the excess water has to be drained onto grassed artificial water ways, often down the slope along the common boundary between two farms.

The second thing to consider is that terraces should not, if possible, be crossed by roads or paths, but the drainage system should start from those points, where terraces are crossed (Fig.7). The layout of terrace lines should normally start with the top terrace, beginning from the outlet end.

The drainage area above the top terrace is often recommended not to exceed 3 acres of undrained and impermeable ground: otherwise it is advisable to construct a diversion ditch along the upper boundary of the farm. For this hillside ditch earth should be removed from the furrow and placed on the lower side. The minimum cross section should be about 2 sq.feet (2 - 3 feet wide, 1 - 2 feet deep). The best is if every farm can have a hillside ditch along its upper boundary.

If the topography is irregular or rocky, it may be better to start with a "key terrace": a) below rock outcrops, b) above steep slopes, or c) below homesteads. If there is a sharp break in the slope, the "key terrace" should be laid out along the upper edge of the steep slope. Examples of terrace lines on a hill, as well as on a ridge are given in Fig. 8 on p.80.

Siting of  
terraces on a slope

Fig. 7

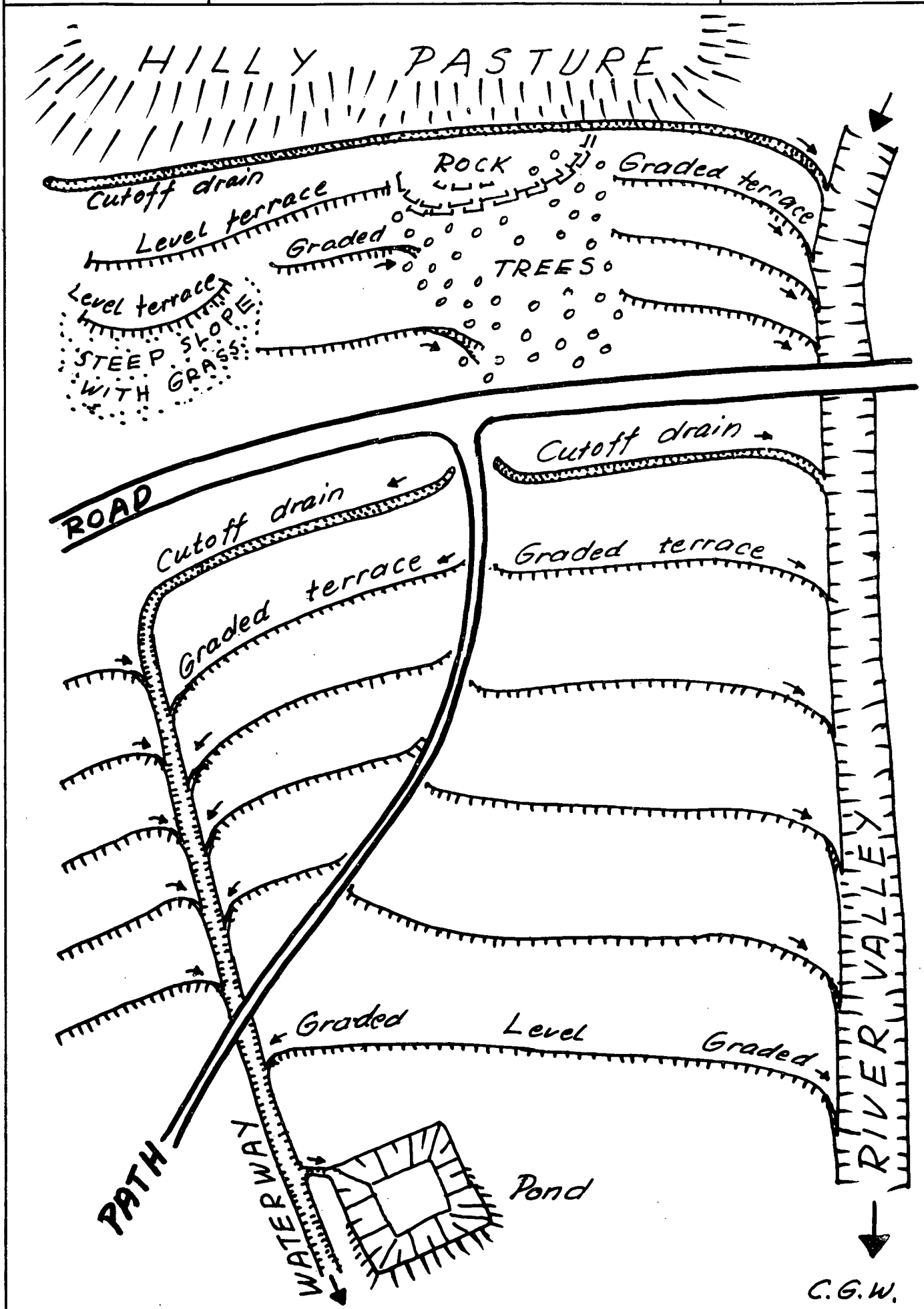

7325 01 - 113 A4

Siting of terraces  
on a hill and on a ridge

Fig. 8

Terracing on a hill

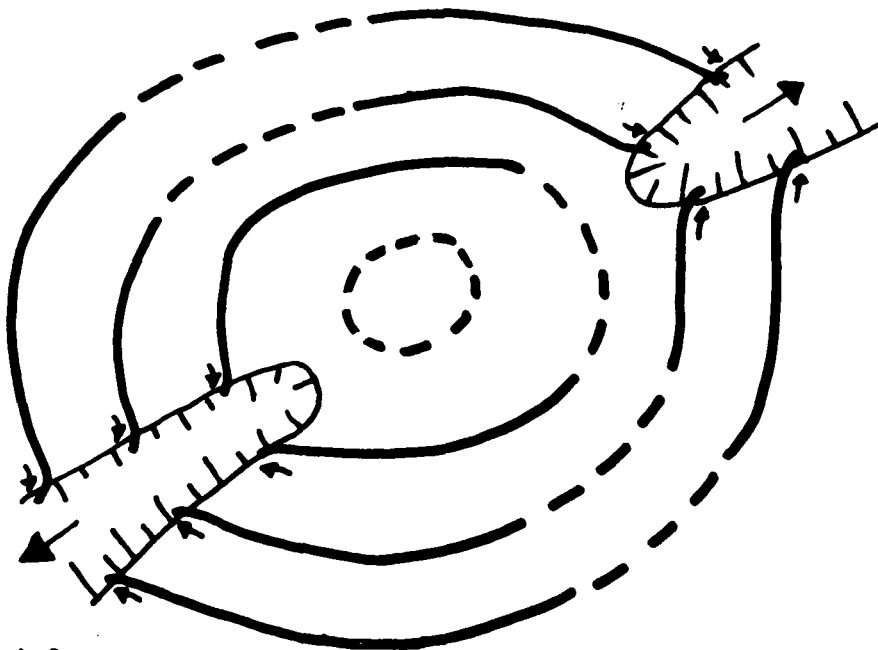

Terracing on a ridge which  
lower down divides  
into two ridges

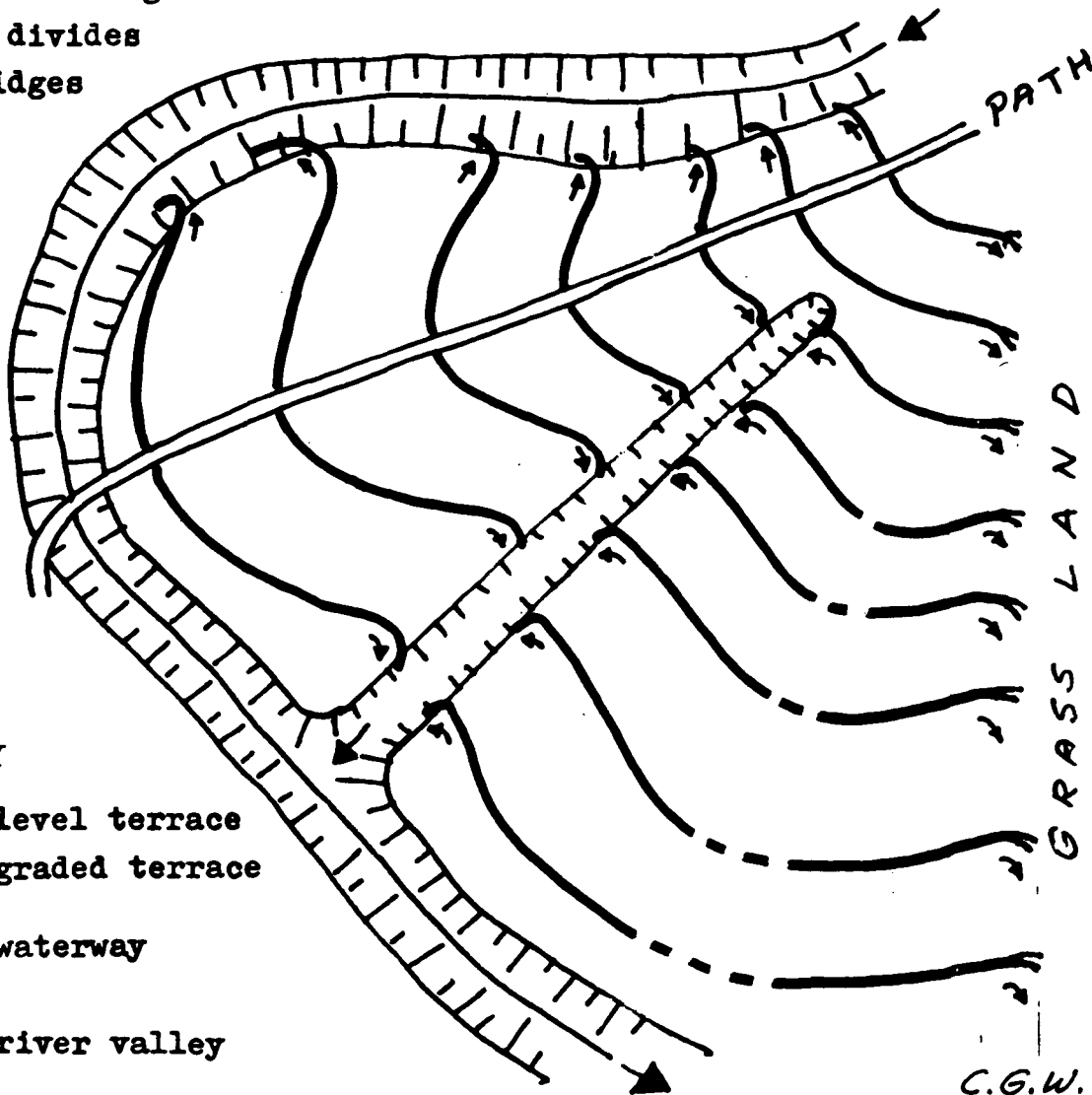

KEY

- level terrace
- graded terrace
- waterway
- ▨ river valley

GRASS LAND

C.G.W.

Spacing

Measuring

Spacing can be expressed as the difference in height between two succeeding terraces (the vertical interval, abbreviated as V.I.), or as the width of a terrace (the horizontal interval, abbreviated as H.I.). The horizontal interval is often measured by actually taping on the ground down the slope instead of measuring horizontally, but for steep slopes the true horizontal distance should be used. If the % of slope changes along the contour - and it usually does - a horizontal measure cannot be used for the layout work. Instead the vertical interval between terraces is usually used (Fig. 9).

The V.I.

In parts of tropical Africa, including Kenya, the vertical intervals are calculated as:

$$V.I. = \frac{\text{percentage of slope}}{a} + b = \text{height in feet (to be multiplied by 0.3 to give metres).}$$

a = rainfall  
b = erodibility of the soil

The percentage of slope in the formula expresses the average land slope above the terrace line.

The factors of a and b of the formula depend on the rainfall and erodibility of the soil. In countries like Kenya with very intense precipitation a = 4. For the erodibility of the soil usually b = 2, but can be varied according to the rate of erodibility:

- high (silt) b = 1
- medium b = 2
- low (clay) b = 3

However, the b-factor has not been varied in Kenya. Instead the figures arrived at through the formula for the V.I. have been increased or decreased by up to 25 % depending not only on soil but also crop and management. In not easily eroded soil (stiff clay) the V.I. sometimes has been doubled.

Consequently the ordinary formula for calculation of the vertical interval is:

$$V.I. = \frac{\% \text{ slope}}{4} + 2 \pm 25 \%$$

Example: For a slope of 12 % the vertical interval is  $\frac{12}{4} + 2 = 5$  feet (1.5 m).

The H.I.

According to the example the percentage of slope is 12 % (12% means a drop of 12 feet in 100 feet):



Why a vertical interval  
usually should be used

Fig 9

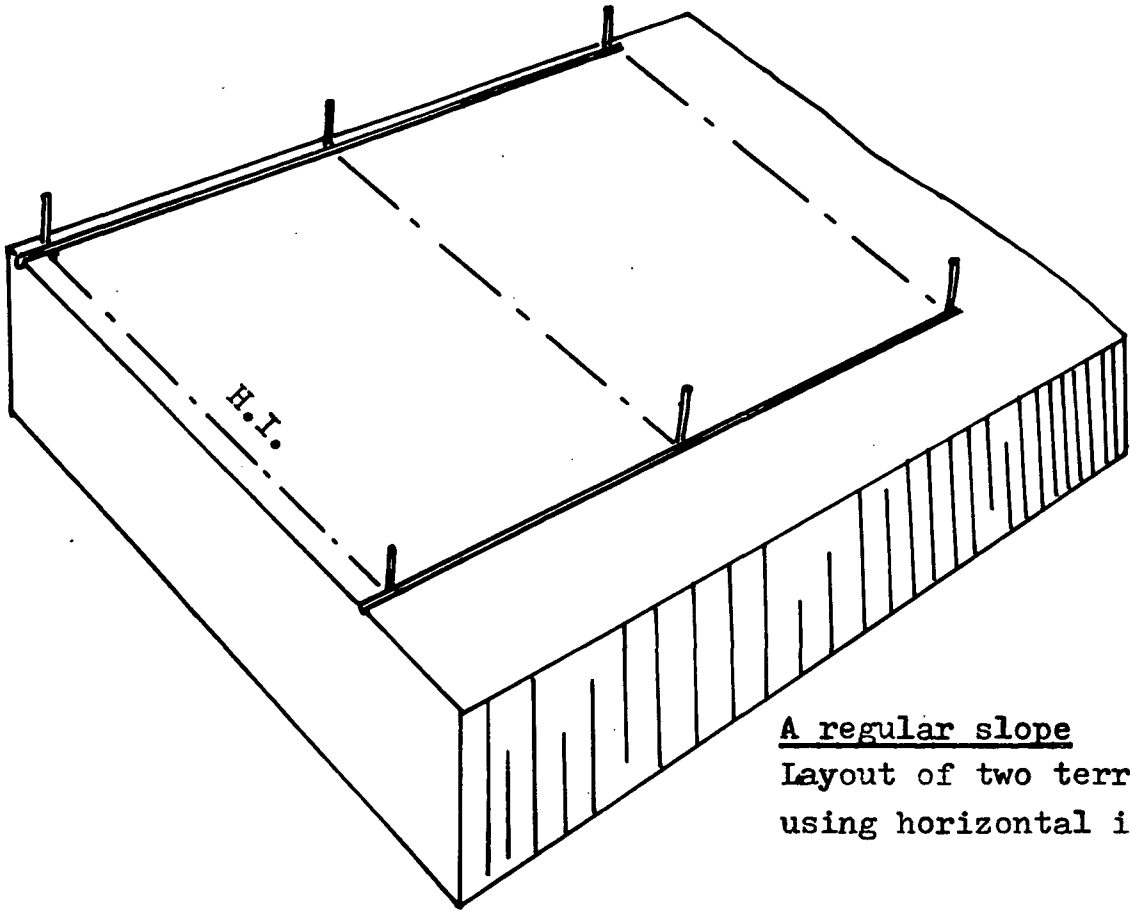

A regular slope  
Layout of two terraces  
using horizontal intervals

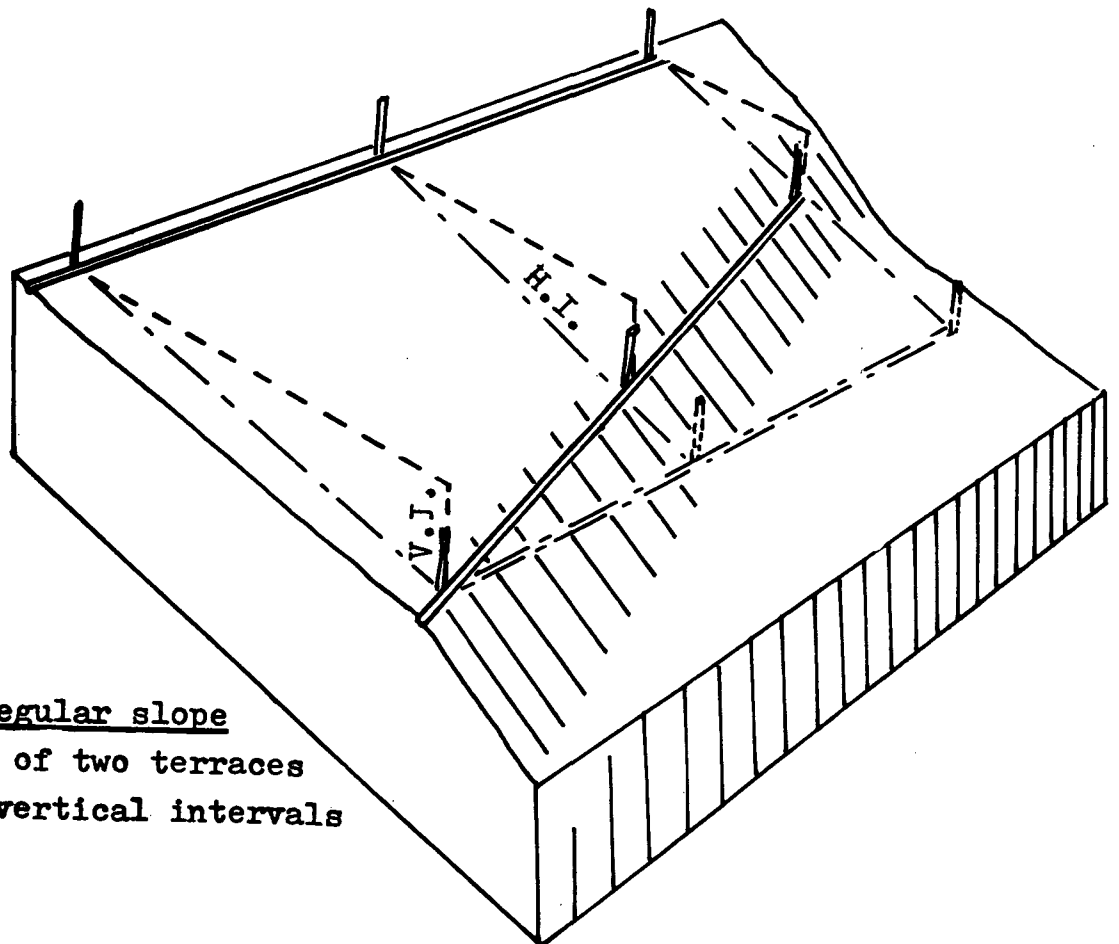

An irregular slope  
Layout of two terraces  
using vertical intervals

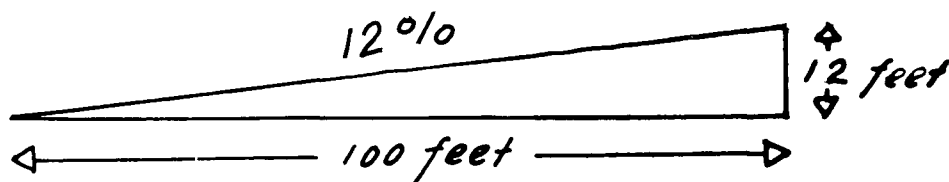

And according to the example the V.I. was calculated to be 5 feet:

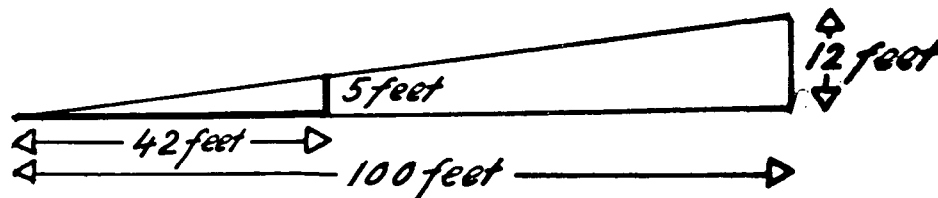

As there is a relationship between the verticals and their horizontal lengths in the triangle, the horizontal length in our example will be:

$$\frac{12}{100} = \frac{5}{\text{H.I.}}$$

Thus we arrive at the following formula for calculation of the horizontal intervals:

$$\text{H.I.} = \frac{\text{V.I.} \times 100}{\text{percentage of slope}} = \text{V.I. being expressed in feet or metres).}$$

Example: The horizontal interval is  $\frac{5 \times 100}{12} = 41.7$  feet (42 feet).

### Discussion

In Fig. 10 and Fig. 11 the vertical and horizontal intervals have been calculated and produced as graphs.

As can be seen from the graph Fig. 10 the various figures for the erodibility factor (b = 1, 2 or 3) give small differences in the vertical interval. This is the main reason why b is usually set as 2.

If the formula is used for slopes from 20 % to 55 % the vertical interval will increase from 2 to 6 metres (Fig. 10). For the same percentage of slope the horizontal interval will be about 10m, (Fig.11).

If the farmers do not want such high rises for the terraces, a special formula can be used for the bench terraces:

$$\text{V.I.} = \frac{\% \text{ slope}}{8} + 1 \text{ or } \text{V.I.} = \frac{\frac{\% \text{ slope}}{4} + 2}{2}$$

which will give half the figures of the ordinary formula and more realistic values for heights of bench terraces (see the dashed line in the graph of Fig.10).

Vertical interval in metres

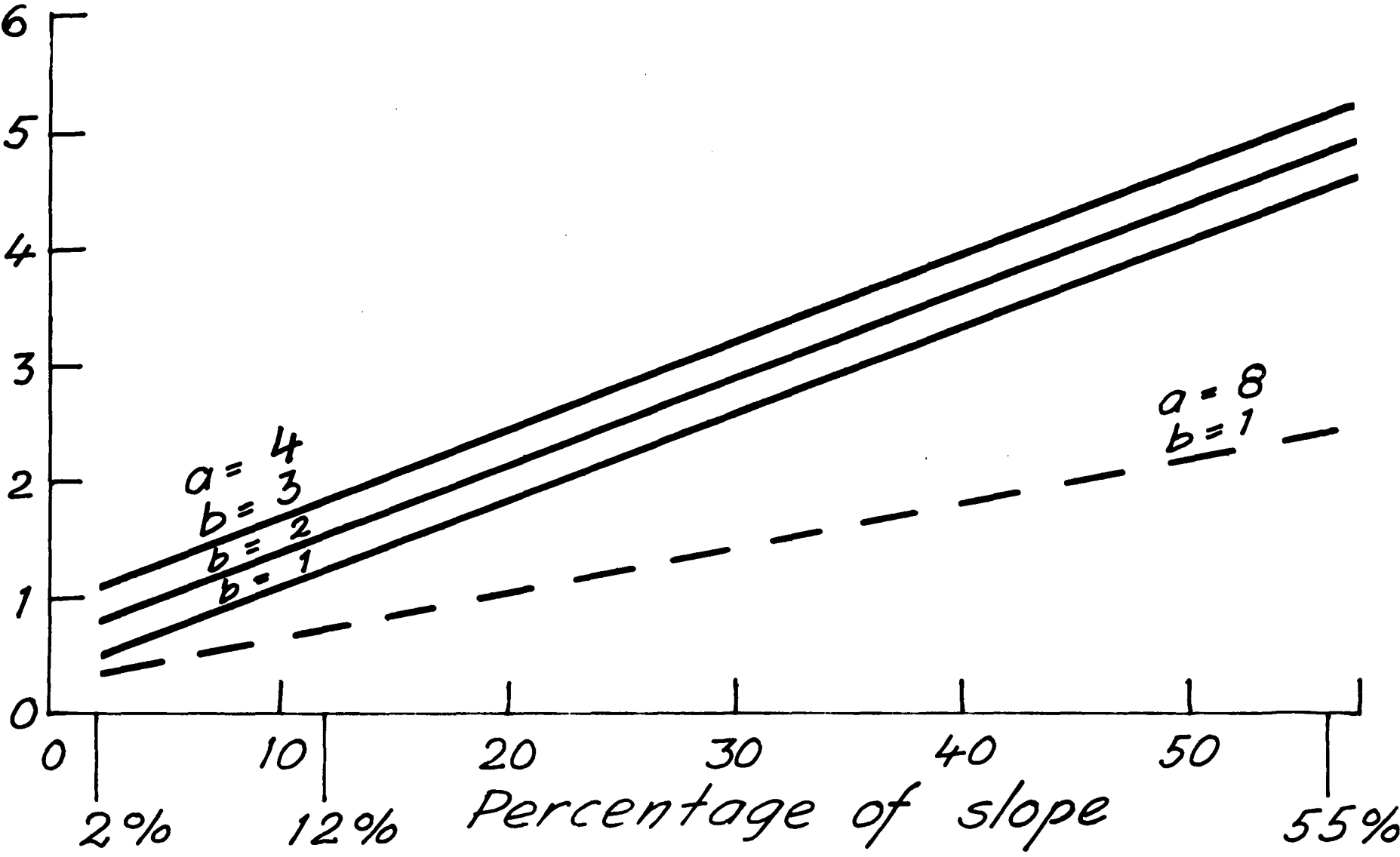

Vertical intervals  
calculated using the formula

Fig. 10

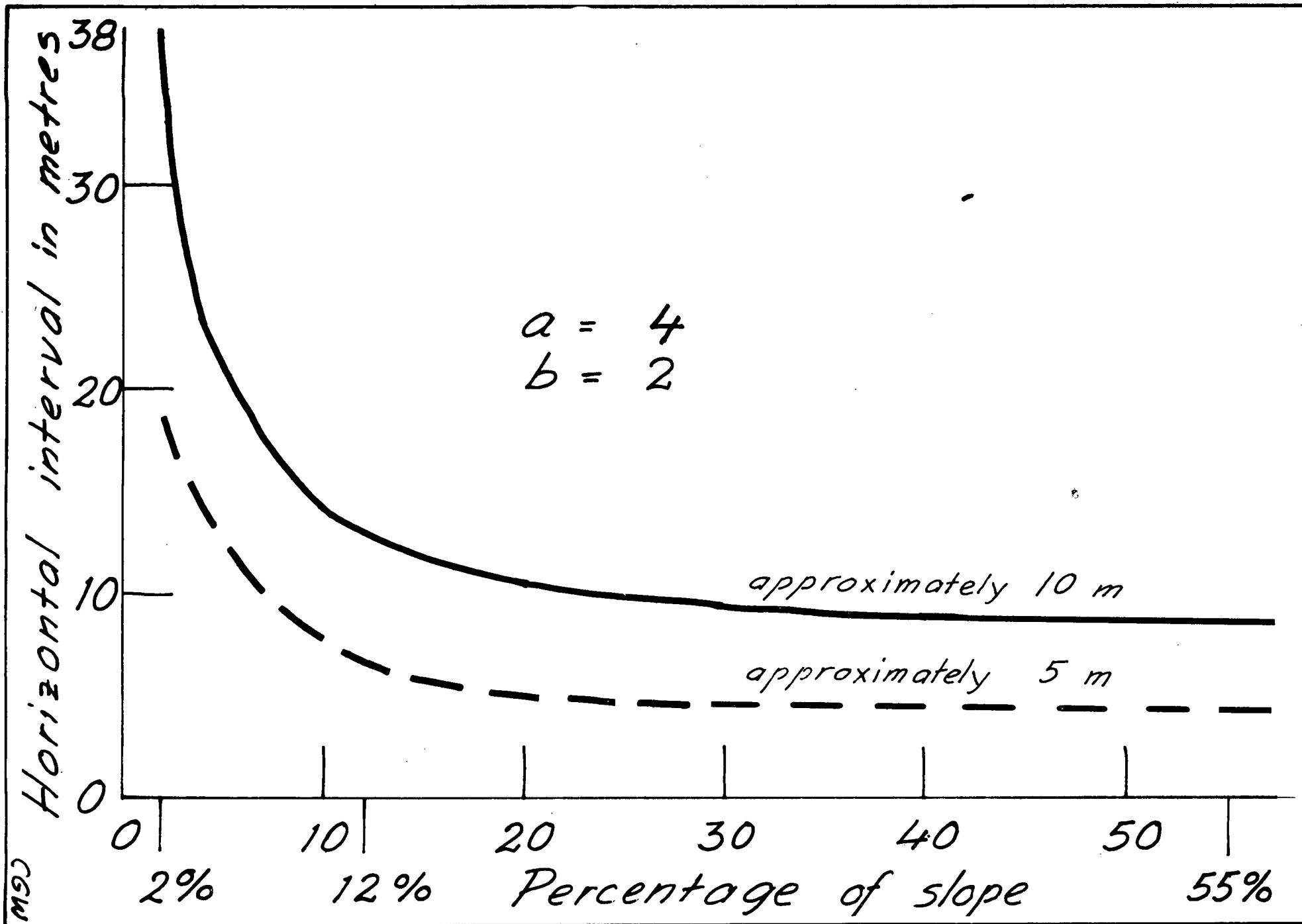

Horizontal intervals calculated using the formula

Fig. 11

However, if the horizontal intervals are calculated as:

$$\text{H.I.} = \frac{\text{V.I.} \times 100}{\% \text{ slope}}$$

the widths of the bench terraces will usually be about 5 metres for slopes between 10 % and 55 % (see Fig.11).

Horizontal intervals of 10 or 5 m, as calculated according to the formulas used in Kenya, will not give decreased spacing the steeper the slope is (see the upper graph, Fig.12).

But if a constant vertical interval is used, the spacings will be less the steeper the slope is (see the lower graph, Fig.12).

A constant vertical interval of 6 feet (1.8 m), i.e. the eye height of a tall man, will give reasonable heights and widths of terraces on slopes exceeding 12 % (Fig. 13):

On slopes of	A width of bench terrace (horizontal interval)
55 %	3 m (10 feet)
33 %	5 m (15 feet)
12 %	15 m (45 feet)

As the eye height varies between 5 and 6 feet (1.5 and 1.8 m), the constant vertical interval used might be increased or decreased up to one foot.

Also topographical conditions might necessitate changes in the constant vertical interval used.

On slopes of less than 12 % the formula will give the following horizontal intervals:

10 %	(14 m)
8 %	15 m
6 %	18 m
4 %	22 m
2 %	( 38 m)

A horizontal interval of 38 m as calculated in the table above is not always used in Kenya. Anyhow, if cultivating maize on erodible soils, a maximum horizontal interval of 24 m is used.

The soil conservationist Colin Maher who worked in Kenya for many years and who visited Uganda in 1945, found that the main method of erosion control on gentle slopes between 1 % and 5 % was contour strips of grass 3 yards wide, at a constant horizontal interval of 72 feet (24 m).

This is in accordance with the present practice of farmers in many parts of Kenya, but the grass strip is nowadays never as wide as 3 yards.

Nevertheless they have developed into benches.

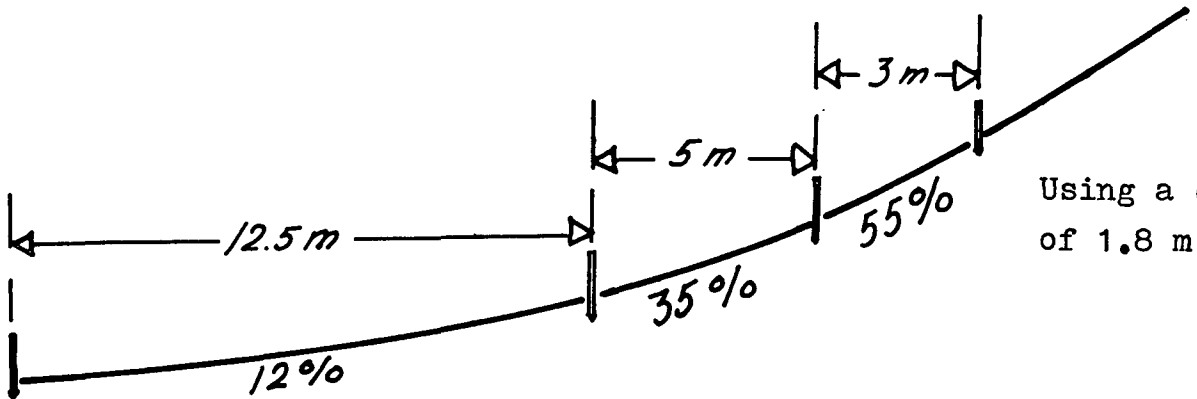

Using a constant vertical interval of 1.8 m (6 feet)

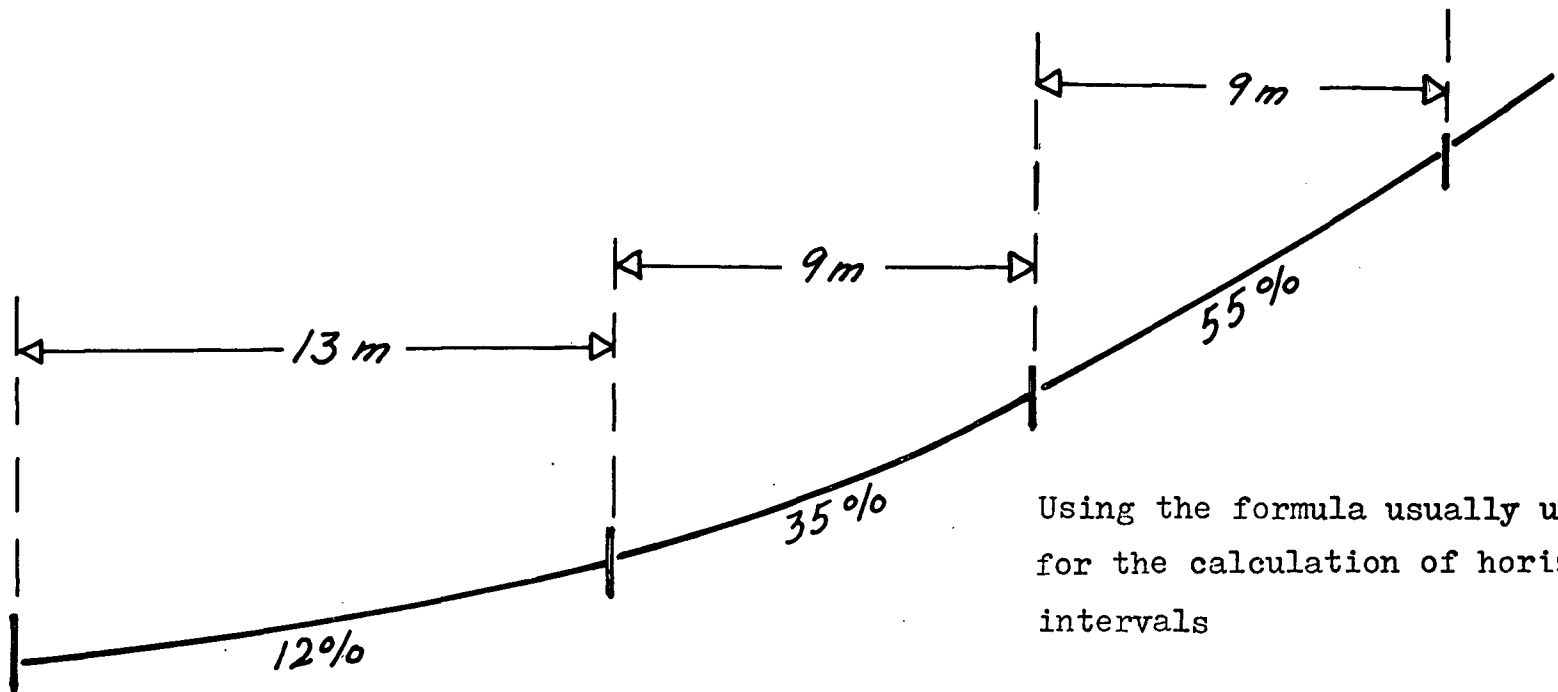

Using the formula usually used for the calculation of horizontal intervals

Horizontal intervals on increased percentages of slope using two calculation methods

Fig. 12

C.G.W.

A constant drop of 1.8 m (6 feet) gives widths between grass strips as shown below

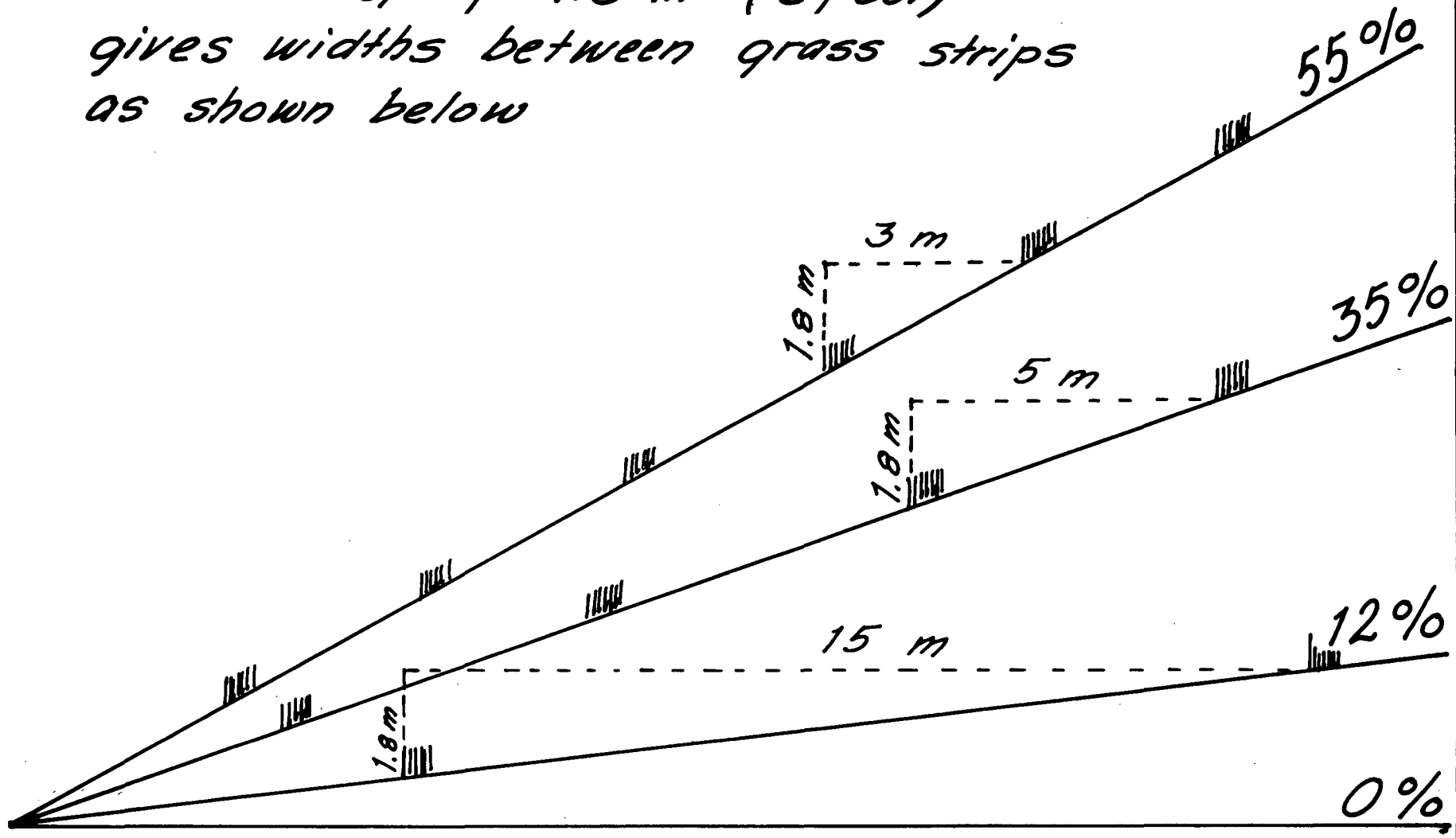

C.G.W.

Widths of bench terraces on slopes of 12%, 35% and 55%

Fig. 13

We have found that a constant vertical interval of 5-6 feet (1.5 - 1.8 m) can always be used for different percentages of slope (Fig.12, p. 86). If we try to use the ordinary formula, and draw the benches on different percentages of slopes, we shall find that the formula gives extraordinarily high terraces above a slope of 12 % (Fig.14 next page).

But half of these values, according to the bench formula, can be used for slopes of up to 35%. Thus we shall arrive at the following rules for the calculation of vertical intervals:

4 - 12 %	a constant vertical interval of 5-6 feet or the ordinary formula or the bench formula	(for slopes less than 4% the H.I.= max. 24 m when in erodible soils and maize etc. is cultivated)
12 - 35 %	a constant vertical interval or the bench formula	
35 - 55 %	a constant vertical interval (or modified bench terraces)	

The horizontal intervals using various calculation methods are shown in the graphs below:

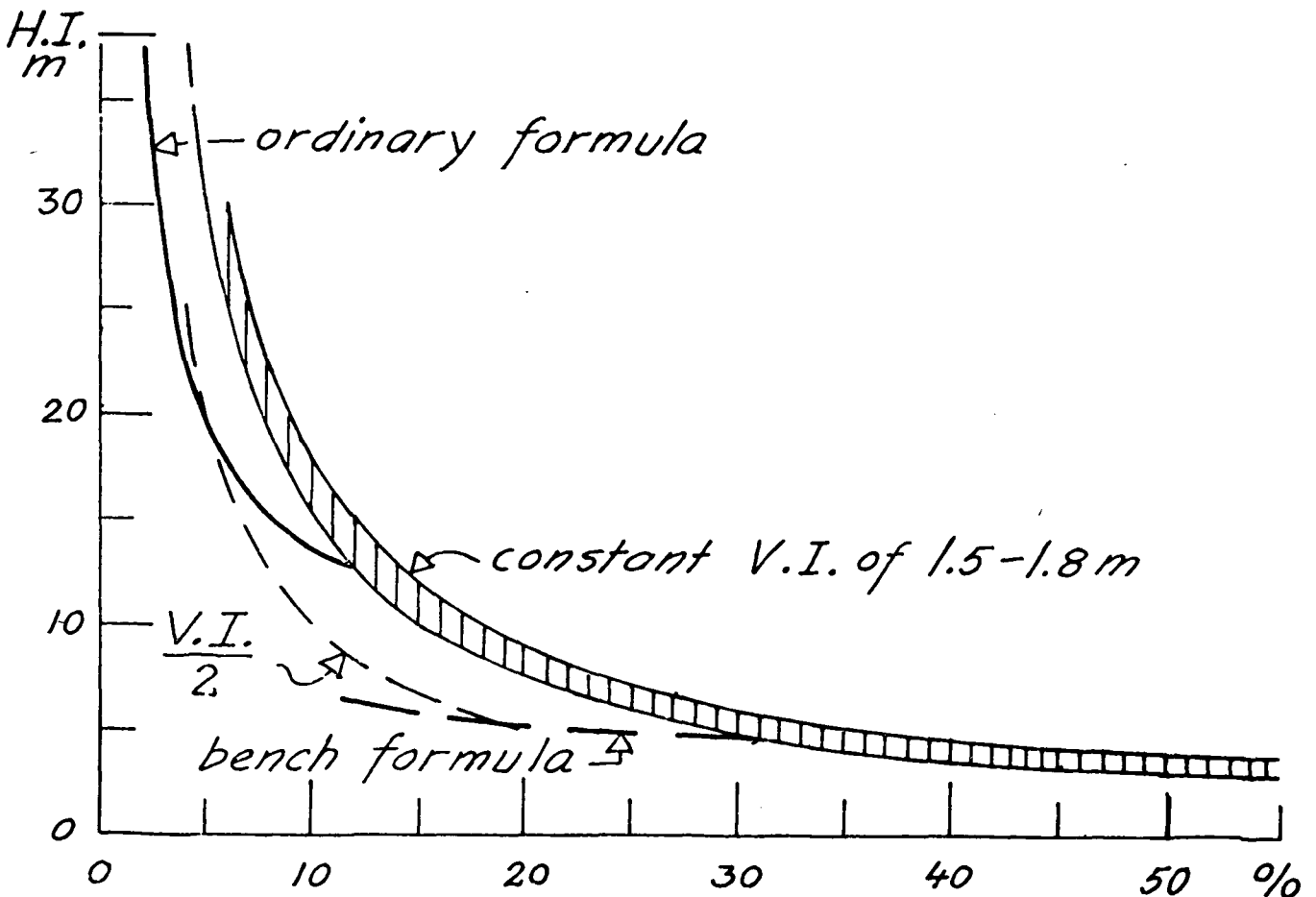



Calculated theoretical V.I. values in metres

Slope %	according to ordinary formula	according to bench formula	constant V.I. of 6 feet
55	5	2.5	1.8
35	3	1.5	1.8
12	1.5	0.75	1.8

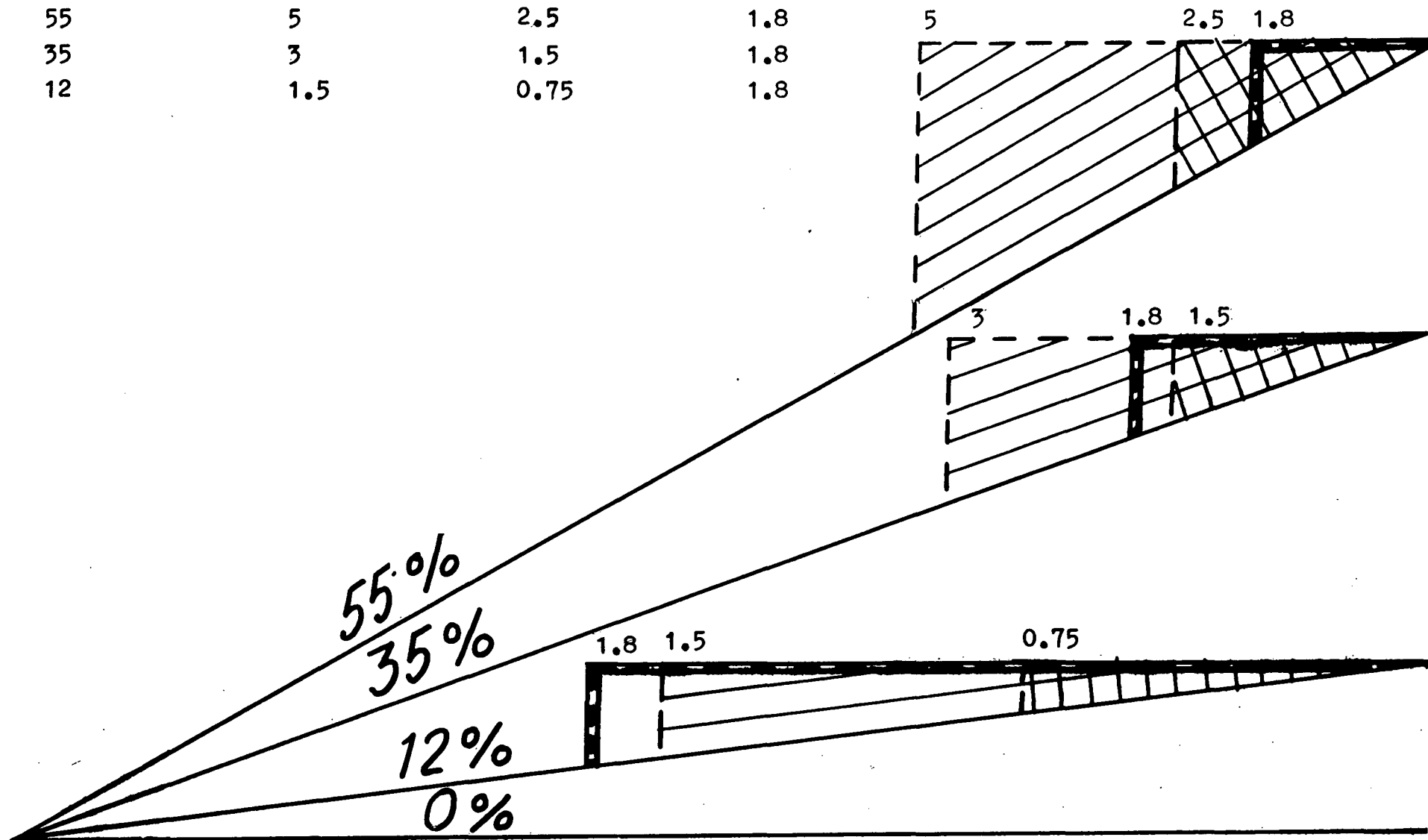

Widths of bench terraces on slopes of 12%, 35% and 55%

FIG. 14

Formation of bench terraces

The graphs below show the calculated soil losses for various percentages of slope and for two extreme types of soil erodibility (sand and loam). Though the slope is terraced, the soil losses are too large in loam soils on steep slopes (more than 5 tons/acre/year). Consequently terracing by itself would not be a sufficient method. The percentage slope (the gradient) has to be decreased.

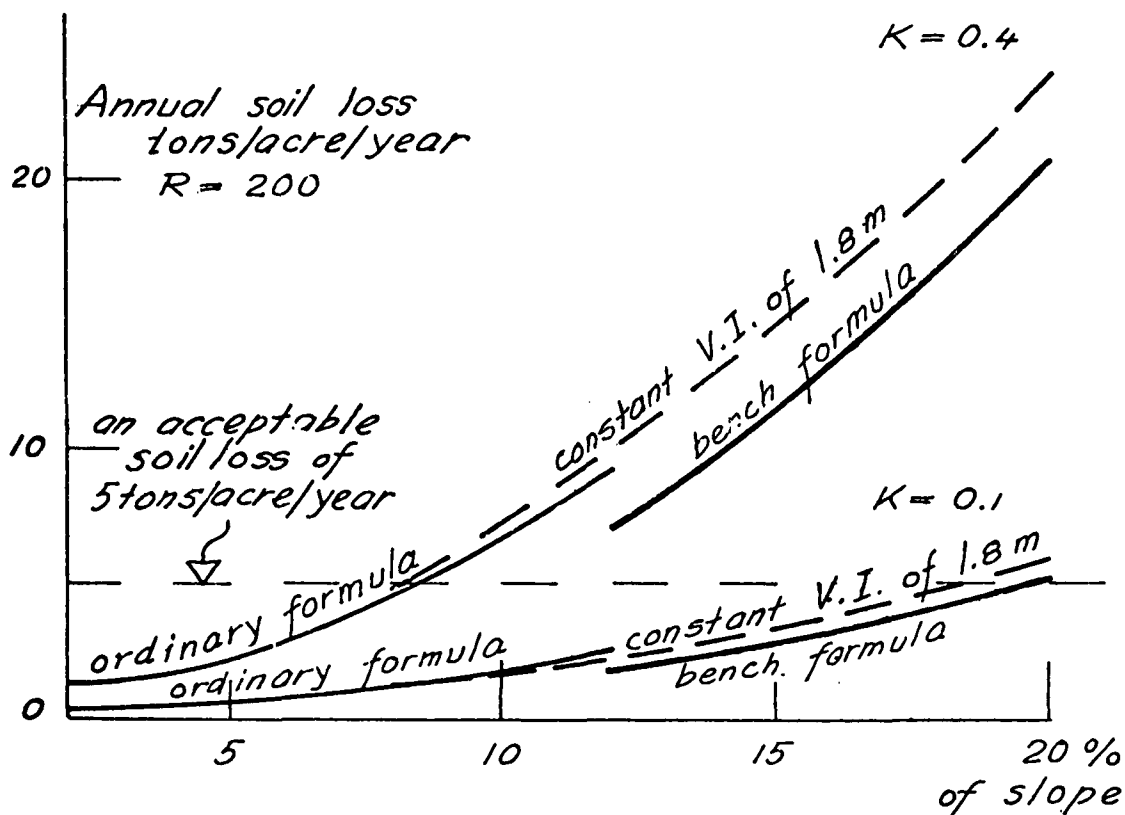

The graphs on the next page show how much the percentages of slope have to be decreased to reduce the soil loss to an acceptable level of 5 tons/acre/year. For example a terraced slope of 20 % has to be decreased by 11 %, and a slope of 12 % has to be decreased by 4 %.

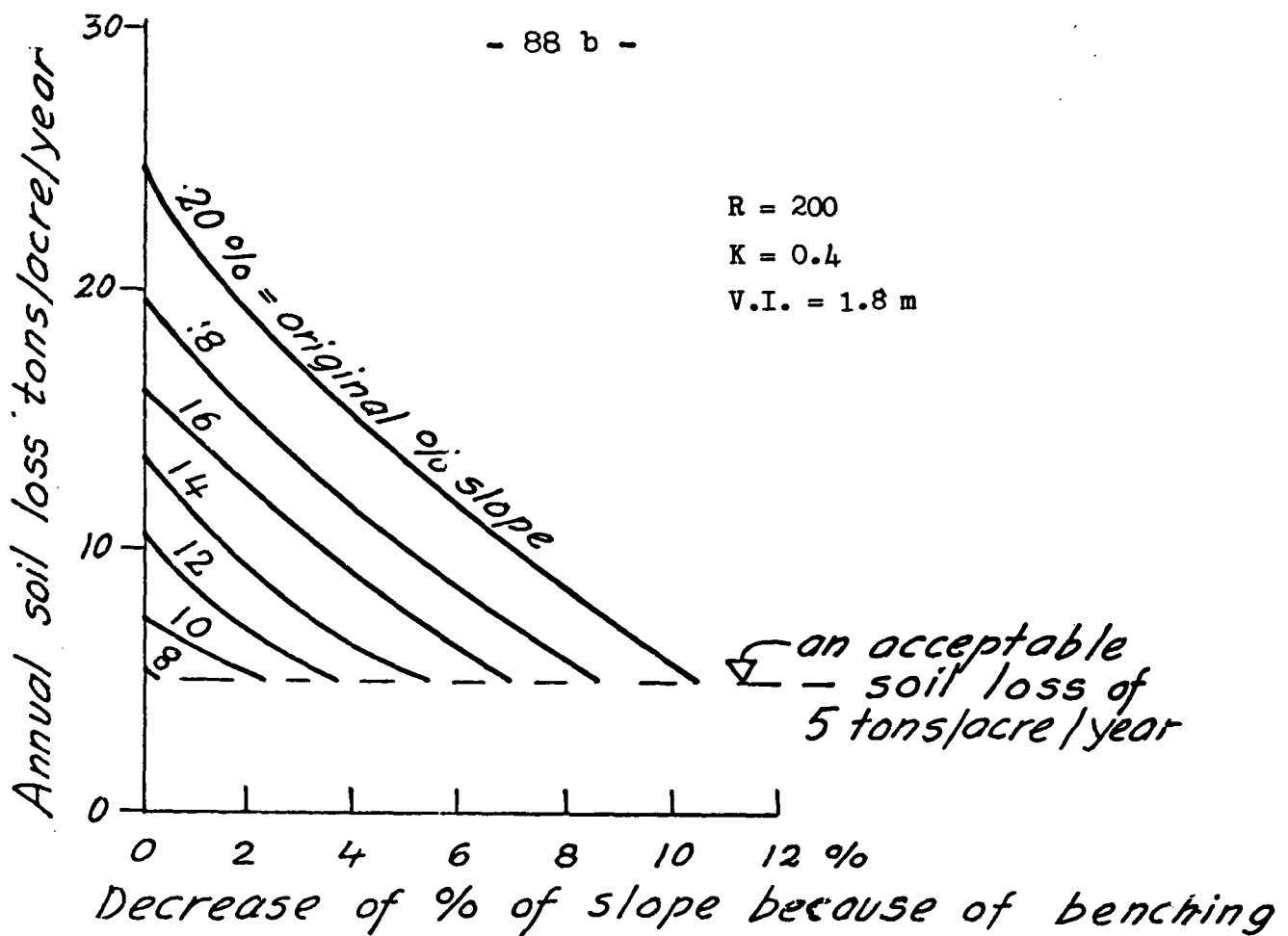

There are two types of bench terraces: excavated and developed. The difference between the excavated and developed bench terrace can be clearly seen from Fig. 15 on p.89.

#### Excavated bench terraces

A developed bench terrace means that your enemy, the soil erosion, is used to form the terrace. This is done by leaving grass strips with permanent vegetation along the contour, thus allowing soil to move down, but be checked by the grass strips. This process will ultimately form a bench terrace. The developed bench terrace can carry water above and along the the grass strip, as well as - and preferably - along the foot of the riser. The subsoil will successively be mixed with the topsoil during the development of a more level terrace.

If a bench terrace is excavated into a slope by digging, the sub-soil will be brought to the surface of the ground in the inner part of the terrace. This can be avoided by scraping away the topsoil from the slope before the excavation, and returning it onto the terrace after excavation work, See the four stages of construction in Fig. 16, p.90.

The construction of excavated bench terraces is usually used only on slopes exceeding 12% and preferably 20%. Nowadays excavated bench terraces are used mainly for coffee, the width of the terraces depending on the percentage slope and the number of rows of coffee bushes.

Differences between  
excavated and developed bench terraces

Fig. 15

EXCAVATED  
(backward sloping)

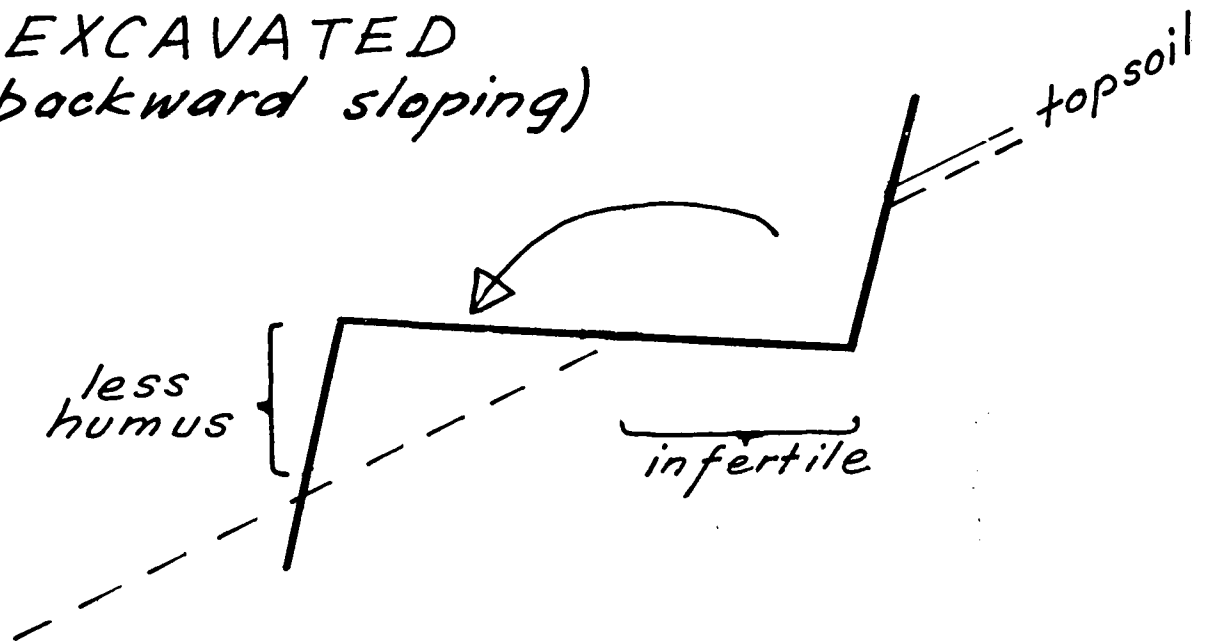

DEVELOPED  
(forward sloping)

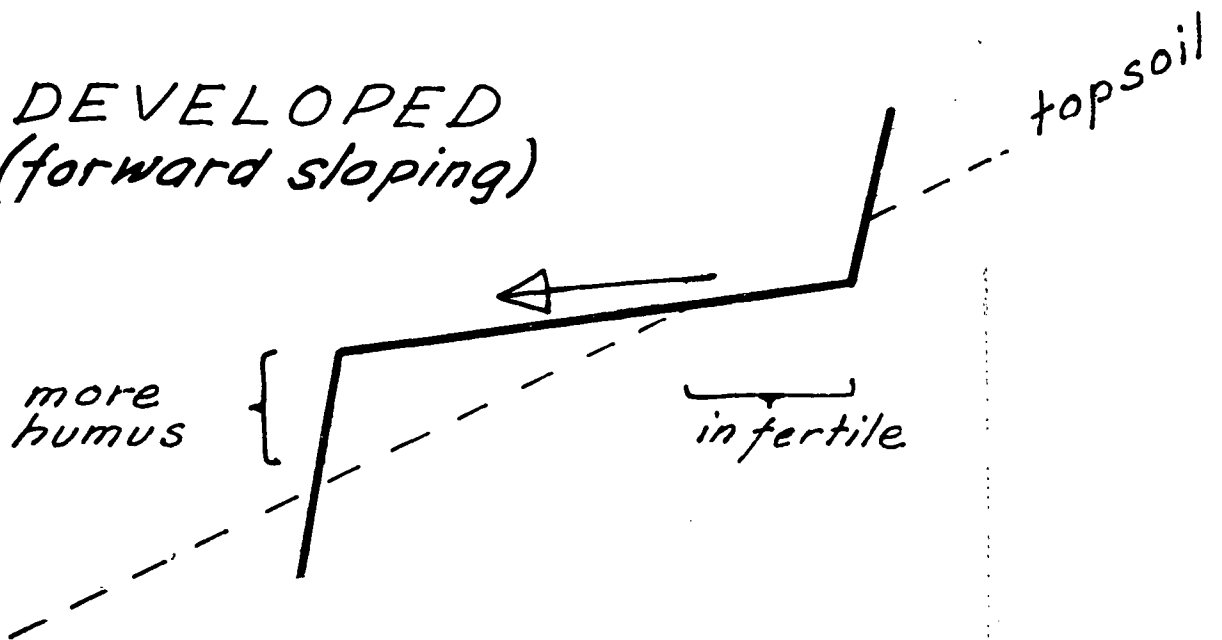

C.G.W.

732501-1137A

Construction of bench terraces

Fig. 16

CONSTRUCTED BENCH TERRACE

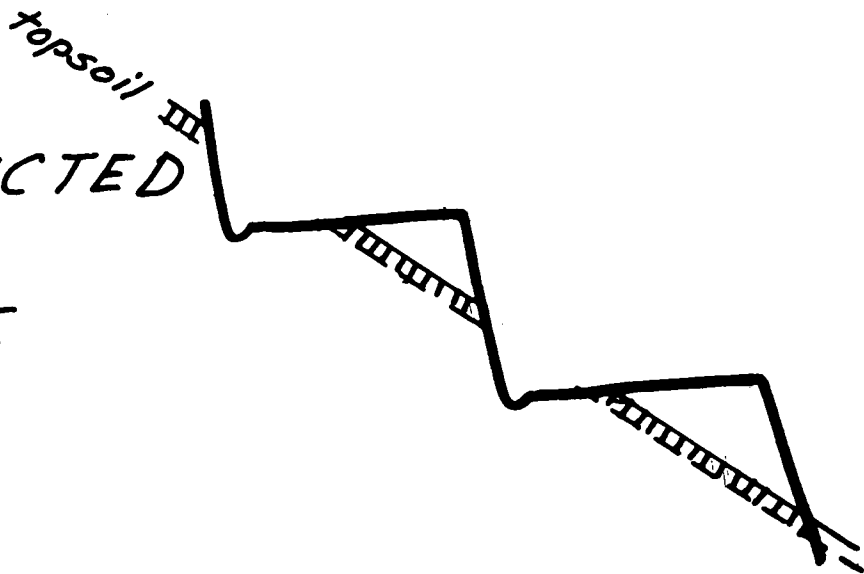

CONSTRUCTIONAL STAGES OF THE CONSTRUCTED BENCH TERRACE:

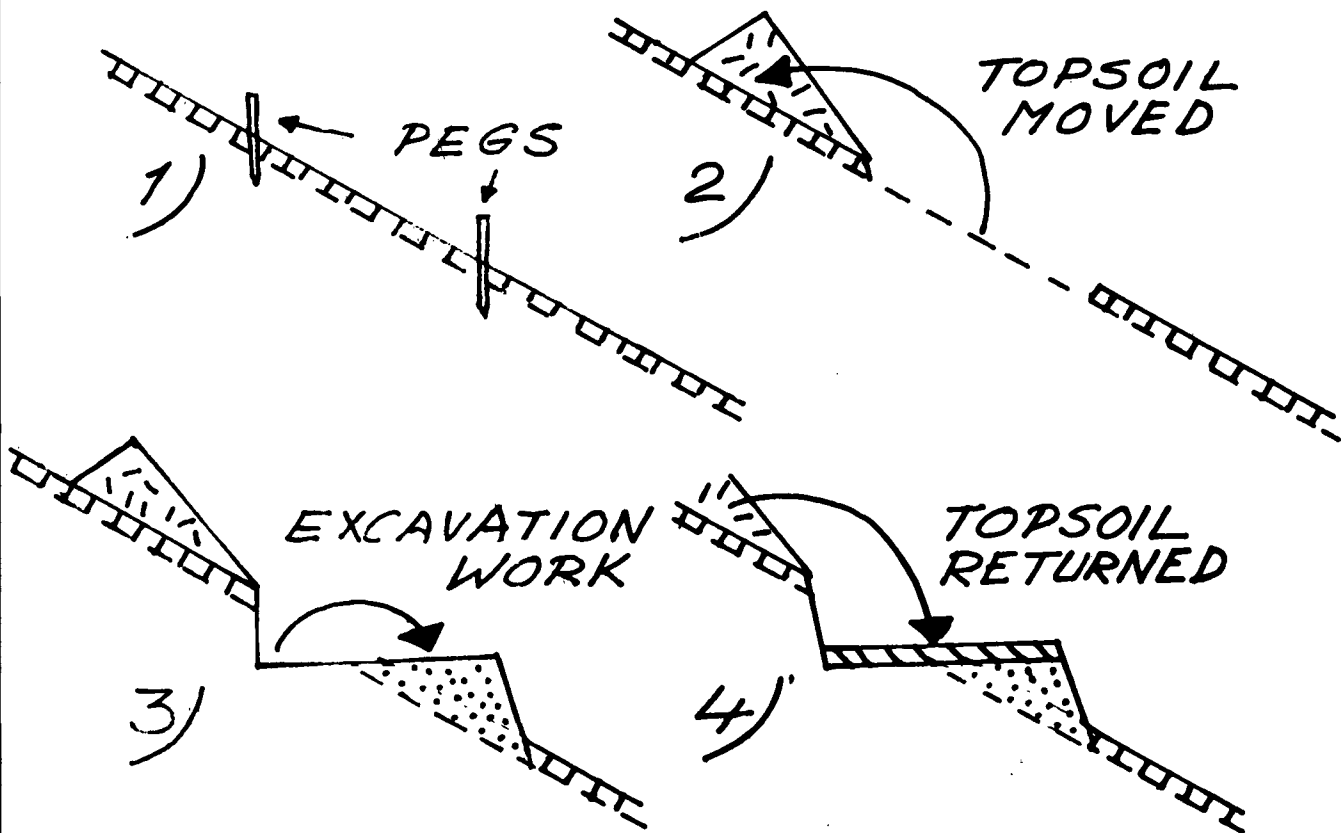

C.G.W.

Modified bench terraces with minimal digging on steep slopes

Fig. 17

Cross section of  
modified bench terrace  
("step terrace")

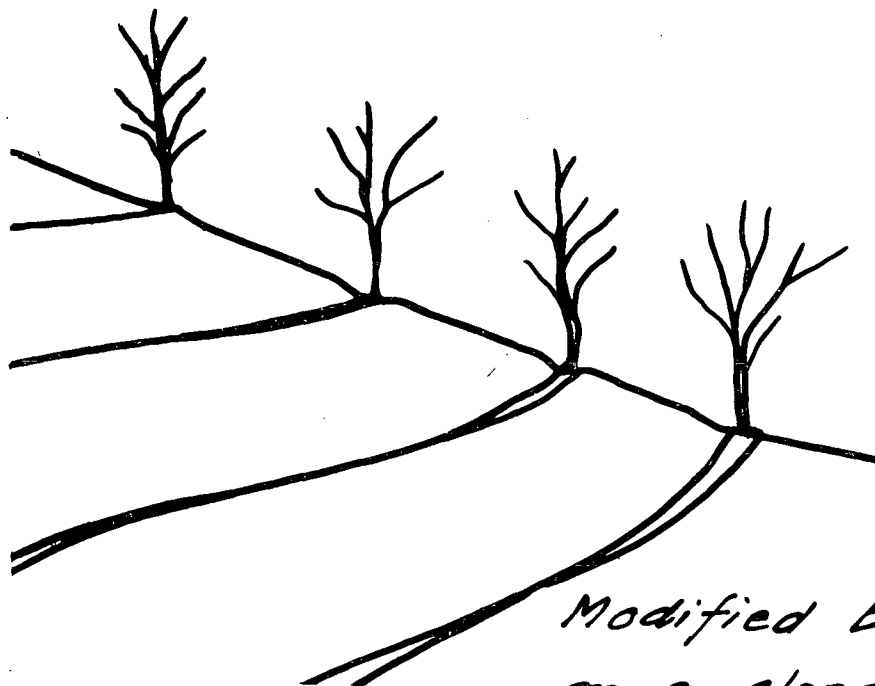
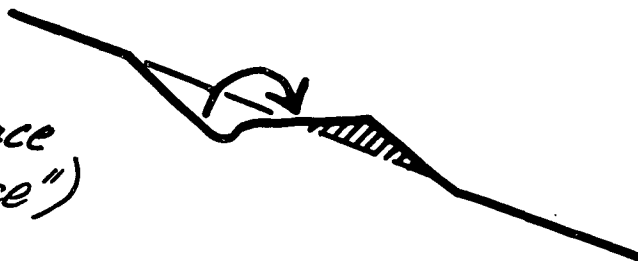

Modified bench terraces  
on a slope of 35%

Modified bench terraces  
on a slope of 55%

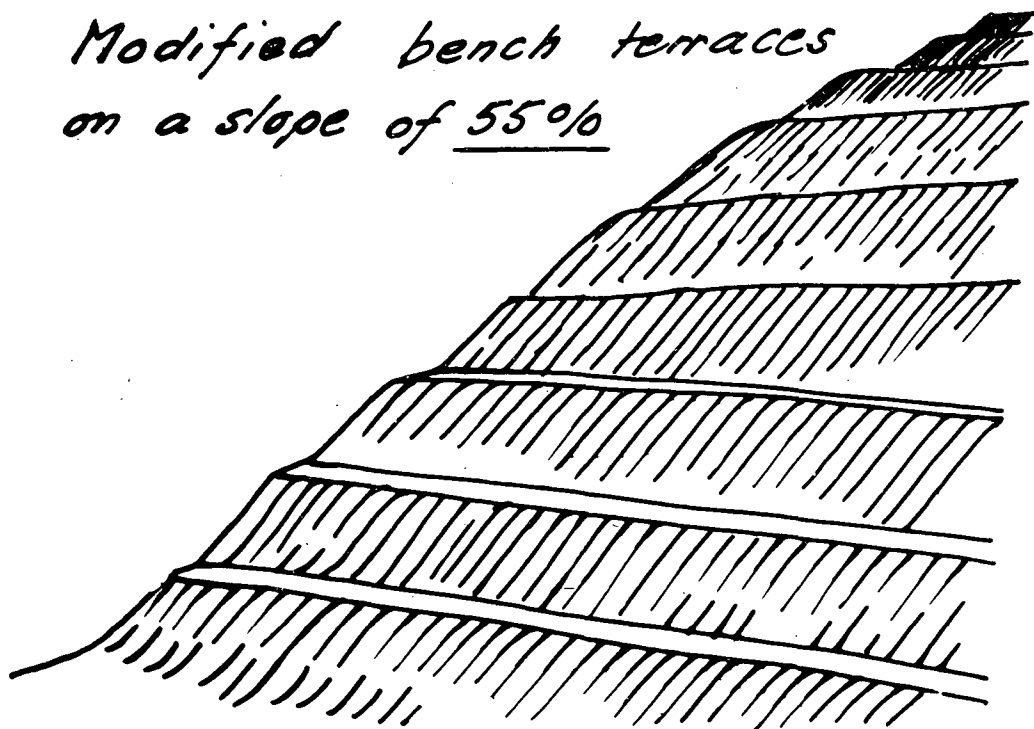

C.G.W.

The excavated bench terrace, which requires a lot of digging work, is expensive and nowadays is used only in exceptional cases. Instead, the modified bench terrace should be used much more. This type of terrace is convenient on steep slopes of 35 - 55 %, and the excavation work is just a small ledge. It is best suited for tree crops and coffee with grass on the riser between the terrace steps (Fig.17, p.91).

#### Developed bench terraces

A developed bench terrace starts with a trash line or a grass strip or a strip of unploughed land as a wash stop. See Fig. 18 on the next page. It is recommended that the pegging for the grass strips should be marked with trash, in the form of small ridges, which will prevent the planting of crops along the strips. Subsequently grass can easily be established in the trash, and when mixed with the soil, the trash will decompose readily.

Ploughing along the grass strips, turning the soil in towards the grass strip, will help to level the terrace. Seven or eight ploughings can give a satisfactory result in hastening the formation of a bench terrace. The grass strip and the level ground of the bench terrace decrease the velocity of water flows and catch the sediment, normally silt and sand. In this layer of permeable sediment there are improved possibilities for infiltration.

The formation of developed bench terraces can also be brought about by the Fanya Juu Method. Formerly, the soil of the channel was moved downhill in soil conservation work, as the soil conservation was regarded mainly as a drainage problem. However, Fanya Juu Method means that the soil is thrown uphill, thereby forming a ridge which catches the soil moved downhill by erosion and cultivation. See Fig. 18, p. 93 and Fig .19, p. 94.

If the soils are erodible, a more or less level bench terrace will develop in 2 - 6 years. The Nyeri District Fanya Juu terraces decreased the original slope by 4.5 % after 2 years and 7% after 4 years (averages based on figures measured by Gitau Nyoro).

For the areas with droughts, e.g. parts of Machakos and Kitui Districts, it can take time to establish a good grass barrier, and already established grass strips can be damaged by droughts. Sometimes the grass is eaten by termites. Consequently the small ridge is often needed more than the grass, which makes the Fanya Juu method to an apt solution for areas with risks of droughts.

The channel which is dug, is primarily used for the formation of a sediment collecting ridge, but the remnants of the channel will act as a drain for surplus water flowing down from the terrace above. If such water flows are too large, the channel of every second or third terrace may be further excavated.

Along the upper boundary of the shamba the soil should be thrown down-hill when digging the "up-hill" ditch, which will prevent water flows from areas above the shamba. The "up-hill" ditch (hillside ditch) can be regarded as a cutoff drain.

Do not confuse the cross-sections of cutoff drains with the ditches dug for Fanya Juu terraces. The cutoff drains can be wide and shallow. The ditches in Fanya Juu terracing should be as narrow as possible so as not to waste too much cultivated land, as the main task is to provide earth for the embankment.



Development of bench terrace  
from a grass strip

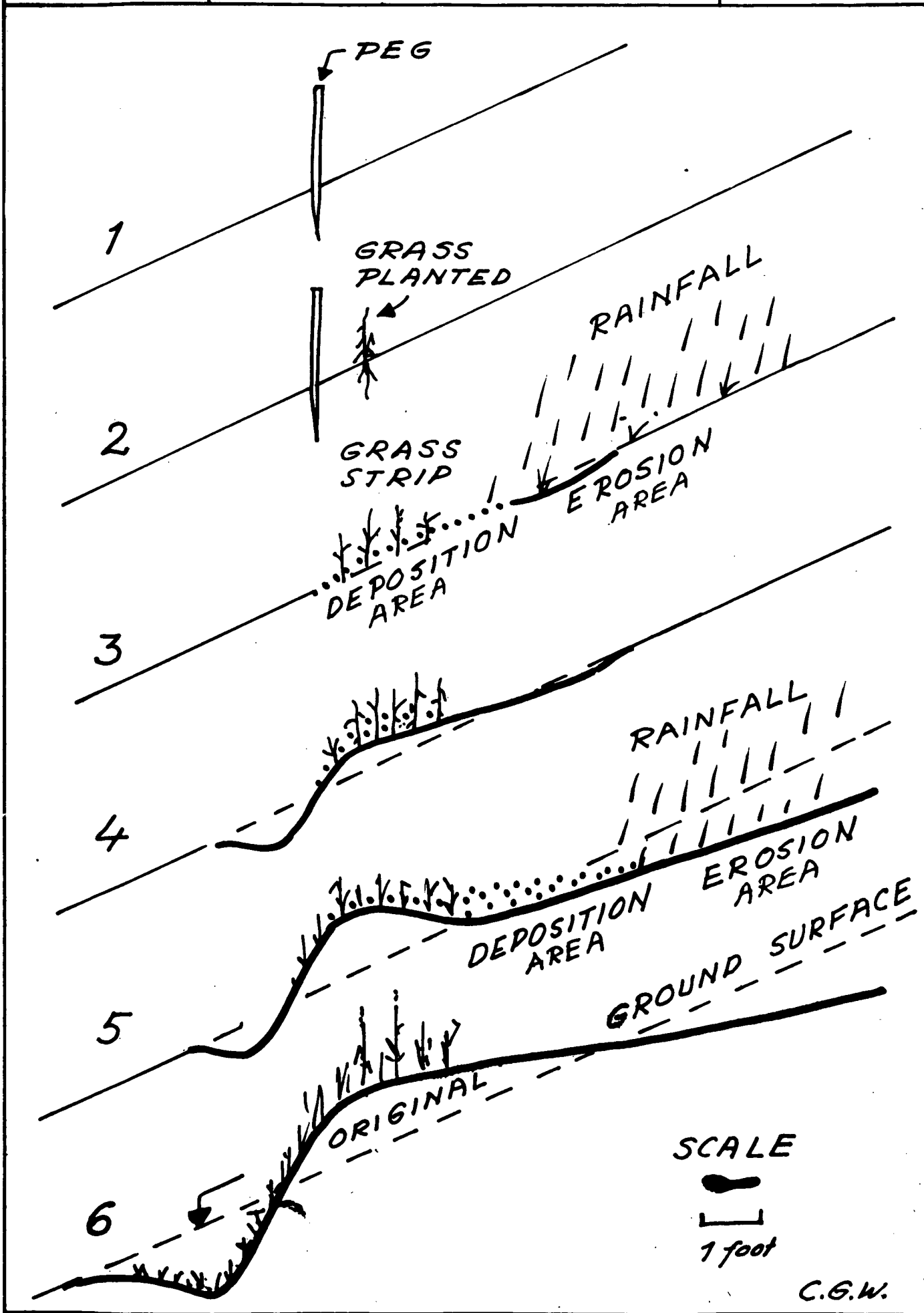

Fanya Juu Terracing

Fig. 19

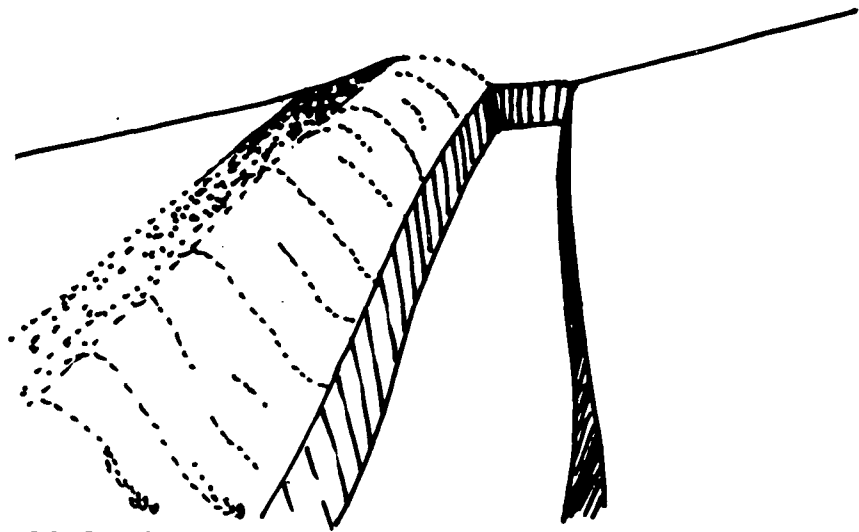

Up-hill ditch  
as a kind of cutoff drain

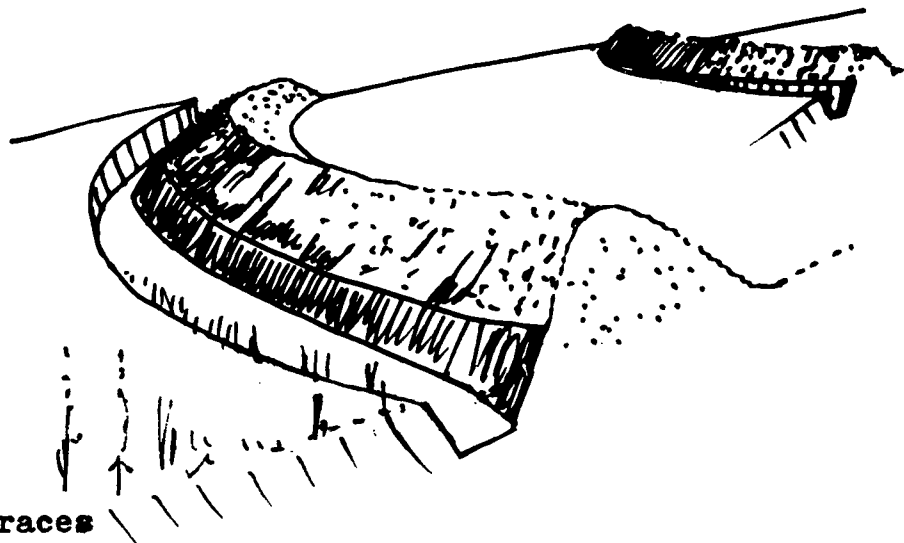

Digging of  
Fanya Juu terraces

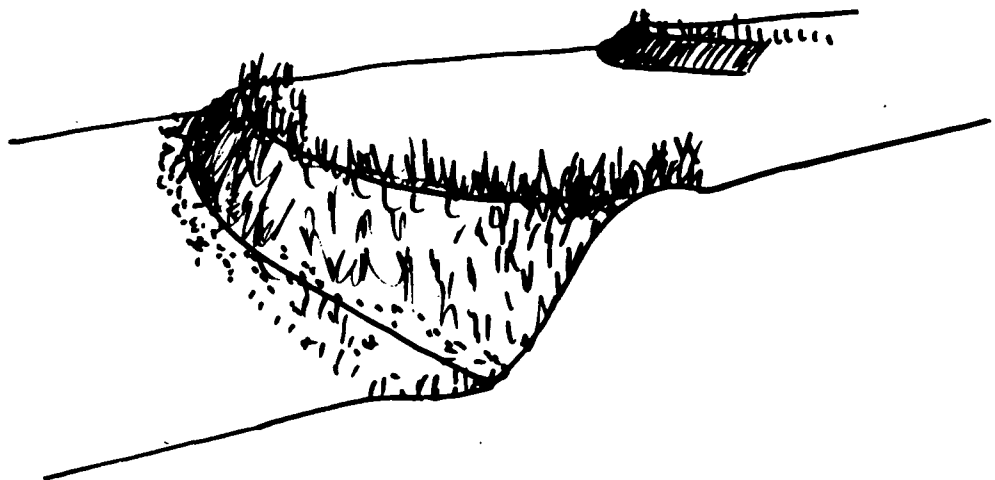

Developed bench terraces

The riser between two bench terraces can be almost vertical in clay soils, but it will be more stable if given some inclination. However, the degree of inclination depends on the type of soil:

Clay, loam and soil with particles heavily coated with iron oxides	about 60° - 70°
Silt and sand	about 30° - 45°

The benefits of bench terraces are:

- 1) A reduction in soil losses caused by erosion from rain, rain water flows and solifluction.
- 2) Soil moisture with nutrients is retained, thus increasing yields, e.g. a 5% increase in soil moisture can increase the maize yield by 15% (Moore 1977).
- 3) Crop operations are made easier than on slopes.

Grass strips have proved to be very effective against soil erosion, especially as the bench develops. Grass strips plus benching does not only mean more level ground and less erosion, but also increased infiltration and less runoff of water on the ground. The increased infiltration is due to:

- 1) The longer time period for infiltration in the grass in the channel below the grass strip and on the benched ground above the grass strip.
- 2) The open channels formed by worms etc. and by dead roots not being clogged so much in the grass strip and the riser.
- 3) The larger soil particle size in the bench, since the clay particles of water flows are not deposited at the same rate as the coarser particles of silt and sand.

The retention of moisture in bench terraces is especially important in dry areas. There are examples from Mitaboni Location in Machakos District (high potential area), where during dry years farmers with bench terraces got normal yields of maize and beans, but farmers without bench terraces did not get any yield at all. Farmers in medium potential areas of Machakos District increased their yields of maize by 50% after introducing Fanya Juu bench terraces.

The loss of nutrients through erosion is not negligible. Measurements on the Ivory Coast have shown an annual soil loss per acre of 10 kg organic matter, 6 kg nitrogen and more than 1 kg phosphorus. In addition there is a loss of nutrients through the superficial runoff of water, probably much greater than the nutrient loss through soil erosion alone.

#### Stone terraces

On stony ground the stones can be gathered from the surface of the ground to build stone barriers, which will catch the soil in the same way as the Fanya Juu Method.

The construction of stone terraces should start with a shallow trench with a level bottom. If not, parts of the stone walls will move down the slope because of solifluction. An example of the design is given in the figure below:

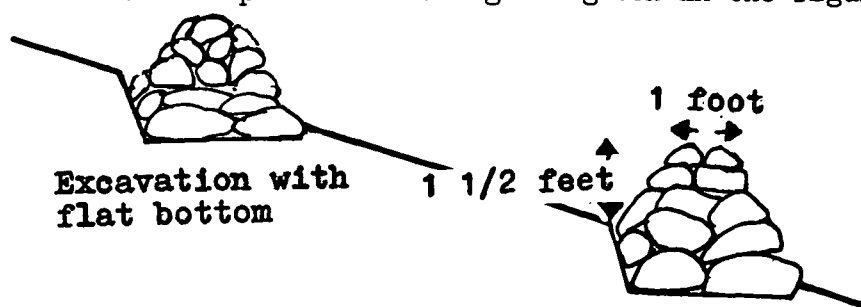

Stone terraces as used in some parts of Kenya, could well be used more widely.

#### Vegetative cover on terrace edges

The terrace edge (and the riser) should be planted with grass. Alternatively natural vegetation can be allowed to regenerate by itself.

The final grass strip must: be dense without spacings between the tufts, because water overflowing the grass strip should be distributed in many small flows at low velocities, with the grass acting as a filter for the transported sediment. To be effective a grass strip should have a minimum width of 0.5 m (1.5 - 2 feet).

The planted grass should, if available, be a stiff-stemmed species, and a high-yielding fodder. The best species, except in arid areas is napier grass (*Pennisetum purpureum*) or bana grass. Real bana grass is a hybrid between babala grass (bulrush millet, *Pennisetum typhoides*) and napier grass, but some "bana grass" in Kenya is instead a variety of napier grass. Bana grass has a thinner stalk and is more rich in leaves than napier grass. It also has more stalks than napier grass, producing a denser cover. As bana grass has deeper roots than napier grass, it is more drought resistant. These grasses can be planted using root splits (with the stem cut off) or as canes (in lengths of 2 nodes with the leaves removed). Root splits come up faster. In loose soils the cane can be put into the ground by hand. In firm soils the canes have to be dug into the ground. They should be laid horizontally not deeper than  $\frac{1}{2}$  inch below the surface. The recommended spacing between the plants is to be 1 foot apart in the row or in two rows with alternating plants 2 feet apart in the row. One man can plant more than 100 m per day (canes dug into the ground).

The optimum height is 5 feet. The grass can be cut every 3rd month, preferably not shorter than a foot above the ground. Such cutting will give a good barrier and will prevent the grass growing on the sides out over the terraces.

A grass used all over the world is Guatemala grass (*Tripsacum laxum*). Its climatic conditions are similar to these of napier grass. Guatemala grass is tall and broad leaved but less productive than napier grass and has a lower nutritive value.

Other grasses used on terrace banks (see Appendix 2, pages within brackets in the list below):

Guinea grass (shade tolerant)	Panicum maximum (p.5)
Nandi grass, Common Setaria	Setaria sphaceolata (p.6)
Creeping signal grass	Brachiaria decumbens
Bahia grass	Paspalum notatum (p.5)
Vetiever grass (for thatching)	Vetiveria zizanioides
Makarikari grass	Panicum coloratum var. macaricariense

Grasses also suitable on risers and in channels:

Kikuyu grass	Pennisetum clandestinum (p.5)
Star grass, Bermuda grass	Cynodon dactylon (p.2)

The two lastmentioned species have rhizomes and stolons liable to run into adjacent cultivated land.

On Fanya Juu ridges the plants should be on the top of the ridge, if planted in a single row. If a second row can be planted, this should be on the ditch side of the ridge, and with plants alternating with the ridge plants. In dry areas it is probably better to plant only on the ditch side of the ridge.

On slopes of coffee terraces grass not competing with the coffee trees should be used, e.g. star grass, Rhodes grass and Guinea grass.

### Gradient

Terraces can be constructed either on the contour (level terraces or "blind terraces") or with a gradient (graded terraces).

#### Level terraces (retension terraces, absorption terraces)

If the soil is permeable and there is a need for water conservation (in areas with an annual precipitation of less than 700 - 800 mm), level terraces are preferable. Level terraces are not recommended on slopes steeper than 3 - 10%.

There are exceptions to these rules, i.e. level terraces also have to be used in not very permeable soils and on slopes steeper than 10 %, if it is not possible to discharge the water from a terrace, or if level terraces already exist and the experience of level terraces is good.

Difficulties in discharging water occur:

- 1) When there is an isolated small slope on a field with resulting terrace lengths of only 10 - 30 m.
- 2) When rock outcrops limit the extension of terraces to a waterway
- 3) When topographical conditions prevent the extension of terraces to a waterway
- 4) When the adjacent farmers will not permit the discharge of water over their farms.

The intervals of level terraces are the same as those for graded terraces.

At present level terraces are not common in Kenya.

It is possible that level terraces can be used much more in arid areas of Kenya, even on slopes steeper than 10 %.

### Graded terraces

In the layout work for graded bench terraces there are the same precautions and rules as for cutoff drains. There is a drainage channel along the foot of the riser, which may be deepened into a larger channel, if necessary

Consequently the gradient recommended is:

heavy soils (of clay or loam)	0.5 %
light soils (silty or sandy)	0.25 %

### Length

#### Level terraces

Level terraces have no maximum length, but dams or "blocks" are recommended in terrace channels, at every 100 or 150 m. or even closer (e.g. 30 m).

In the layout work the ends of the terrace line can be turned uphill, so that no water can flow from the ends of the terrace.

#### Graded terraces

In principle graded terraces should be as short as possible, if possible not longer than 100 m, but sometimes terraces are even longer than 200 m. In small-scale farming the widths of the farms along the contour usually are less than recommended lengths.

### Maintenance

Some rules for the maintenance of bench terraces:

1. Fill up low spots on the terrace edge (grass strip). This maintenance is needed especially during the first years. Old terraces, which have been well maintained do not need much repair.
2. Plant new grass on bare spots of the grass strip.
3. Do not excavate the riser between two terraces:

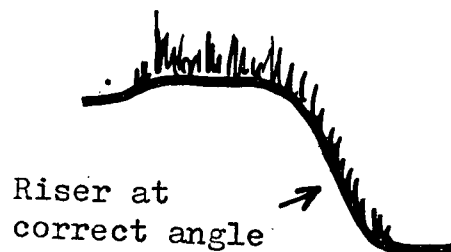
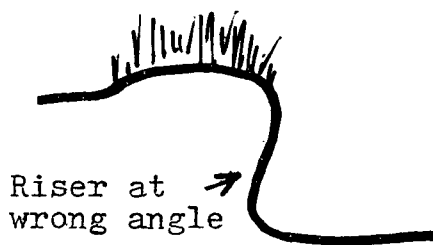

4. Try to maintain a small channel along the foot of the riser for the discharge of water, which may come from the terrace above. Increase this channel if necessary.

A channel might also be needed to drain an almost flat bench terrace preventing water logging.

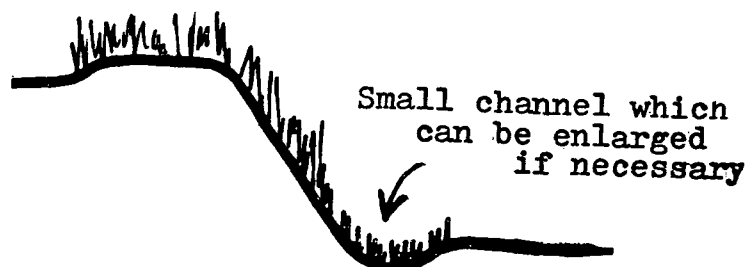

**COSTS**

Cost per volume

The cost of digging work varies due to the type of soil, the availability of labour, the quality of hand tools used and the capability of the staff. Below are some figures for the cost of cutoff drains from various districts in 1976 and 1977. (Since 1976/77 the cost for casual labour has increased by 15 %)

<u>District</u>	<u>Soil</u>	<u>Shs/cu.m</u>	
Baringo		2.25	
Bungoma	rocky	3.90	
Busia		2.50	
Elgeyo-Marakwet		3.00	
Embu	rocky	3.30	
		2.15	
Kakamega		2.60	
Kiambu		2.40	
Kilifi		2.70	
Kisii		2.60	
Kitui		2.50	
	rocky	3.90	
Kwale		2.75	
Machakos		1.75	
Meru		1.80	
Murang'a		2.00	
Narok		2.50	
Nyeri		2.50	
South Nyanza	stiff clay	3.70	
Average for all figures		2.70	(+15% = 3.10)
rocky soils excluded		2.50	(+15% = 2.90)

Close to big cities costs are higher. For comparison it can be mentioned that daily labourers in Nairobi are paid 4.20 Shs/ cu.m (1978 prices, a channel 2 feet wide and 3 feet deep.

Cost per length

As the cross-section dug can be of different sizes, all costs for the excavation of channels should be based on volume unit instead of length. This can be seen from the table on the next page showing the costs in shs/m for different sizes of cross-sections, if piece work payment is 2.90 shs/cu.m:

<u>Cross-sections</u>			<u>Costs in Shs/m</u>
Depth	Average width	Area	
m	m	sq.m	
<u>Fanya Juu terraces:</u>			
0.6	0.6	0.36	1.05
0.9	0.6	0.54	1.35
<u>Cutoff drains:</u>			
0.6	1.2	0.72	2.10
0.6	1.5	0.90	2.60

As can be seen above, the digging cost of a normal cutoff drain is about 2.35 shs/m. The cost of terracing is about 1.20 shs/m.

Cost per man day

A daily worker can dig about 3 cu.m per day, but the volume dug per man day can vary between 2.70 and 3.90 cu.m. With a piece work payment of 2.90 shs/cu.m these volumes will give a wage between 7.80 and 11.30 shs/day.

Costs per area

For planning the costs of conservation, the cost of terracing is often expressed in shs/acre. The cost per acre of terracing depends on the percentage slope and the measure used in the layout of the vertical interval. In the table below the cost is assumed to 1.15 shs. per metre length of terraces:

Slope %	Normal formula			Bench formula			Constant V.I.		
	V.I. feet	H.I. feet	COST Shs/acre	V.I. feet	H.I. feet	COST Shs/acre	V.I. feet	H.I. feet	COST Shs/acre
5	3.25	65	240	1.6	32	480	-	70	218
10	4.5	45	345	2.25	22.5	690	6	60	254
15	5.75	38	40	2.9	19	802	6	40	382
20	-	-	-	3.5	17.5	879	6	30	506
25	-	-	-	4.1	16.5	930	6	24	637
30	-	-	-	4.75	16	950	6	20	762
35	-	-	-	5.4	15.5	990	6	17	895
40	-	-	-	-	-	-	6	15	1,012
45	-	-	-	-	-	-	6	13	1,164
50	-	-	-	-	-	-	6	12	1,243
55	-	-	-	-	-	-	6	11	1,410



A comparison of mechanized and labour intensive work

Terraces can be constructed mechanically or by hand. It is not economic or possible to use machines on slopes exceeding 12 - 15 %. On slopes of less percentage machines can be used under specific conditions:

- 1) the agricultural staff cannot organize labour intensive work
- 2) machines are available at a reasonable rate
- 3) large areas need soil conservation urgently.

Machine-made terraces are usually neither cheaper nor better than terraces made by hand. During the course for technical assistants at Machakos in November 1975 previous terrace works were measured on four farms as practicals using different instruments, to compare costs. The results are shown on pages 102-104.

Farm No. 1 belongs to Mr. Kimonyi Mwakave and Farm No. 2 belongs to Mr. Joshua Mguwi, both in the Wamunyu area of Machakos District. The new terraces measured were constructed in the period March-May 1975 (involving 42.40 and 7.55 effective tractor hours respectively).

Farm No. 3 belongs to one of the shop keepers at Wamunyu. Farm No.4 is situated in the township of Machakos, where daily workers are expensive to engage.

Type of costing	Costs of terracing			
	Mechanized work		Work by hand	
	Farm No.1	Farm No.2	Farm No.3	Farm No.4
	shs	shs	shs	shs
1. per m length of terrace	2.30	2.05	1.60	2.35
2. per cu.m of excavated channel	3.70	(4.55)	2.80	3.90
3. per acre of conserved area	5.73	3.75	427	593
			235	327

On Farm No. 2 the cross-sections of the channels had been reduced to some extent because of ploughing, causing a cost per cu.m rather too large.

The mechanized unit at Wamunyu consisted of one Caterpillar DC 6 and 1 Motor Grader Cat-12 together doing an average of 76 m/h at a cost of 295 shs/hour. <sup>1)</sup>

The largest cross-section measured by me during the construction work was 1 sq.m. which would give an average cost of 3.90 shs/cu.m.

---

1) This figure is probably too low for the year 1976. In a loan application, dated March 1976, written by Mr. Gota and Mr. Spooner, the time rate for only 1 Motor Grader is calculated to be 222 shs/hour, based on 1975 prices.

Farm No. 1

Terracing by  
motorgrader and  
terraces

Terrace No.		Cultivated land (C) or grass/bush (B)	Slope of land above the terrace, %	Vertical interval to higher terrace (or boundary), m	Type of terrace (see foot note)	Longitudinal gradient of terrace, %	Excavated cross- section, sq.m or height of riser, m	Cross-section of filled-up ridge, sq.m	Volume of excavated channel, cu.m	Length of terrace (or boundary of cultivated area), m	Horizontal interval to lower terrace (or boundary of cultivated area), m	Area conserved, sq.m
1	B	7	2.5	C	1.0	1.4	0.2	52	37	5	185	
2	B	8	1.8	OB	1.0	(0.2)	-	-	(24)	26	(624)	
3	B	9	2.3	C	0.5	0.3	0.6	33	109	19	2,071	
4	B	5	2.1	OB	0.3	(0.25)	-	-	(139)	18	(2,504)	
5	B	11	1.7	OB	0.4	(0.2)	-	-	(120)	21	(2,520)	
6	B	12	1.8	OB	0.3	(0.1)	-	-	(115)	21	(2,415)	
7	B	5	1.1	OB	1.0	(0.25)	-	-	(114)	14	(1,596)	
8	C	2	1.4	R	1.2	0.05+0.04	?	89	74	11	814	
9	C	8	2.0	C	0.5	0.4	-	70	175	19	3,325	
10	C	5	1.0	OB	0.6	(0.4)	-	-	(150)	41	(6,150)	
11	C	2	1.4	OB	0.5	(0.4)	-	-	(114)	8	(912)	
Total								244	395	6,395		

Types of terraces:

OB = old bench terrace  
 C = channel terrace  
 R = ridge terrace (with two channels)

Total cost of the terracing Shs 906  
 Cost per m Shs 2.29  
 per cu.m Shs 3.71  
 per acre Shs 573

**Farm No. 2**

**Terracing by  
Motorgrader  
and terracer**

Terrace No.	Cultivated land (C)	Slope of land above the terrace, %	Vertical interval to higher terrace ( or boundary) , m	Type of terrace (see foot note)	Longitudinal gradient of terrace, %	Excavated cross-section, sq. m (or height of riser, m)	Cross-section of filled-up ridge, sq.m	Volume of excavated channel, cu.m	Length of terrace (or boundary of cultivated area) , m	Horizontal intervals to lower terrace (or boundary of cultivated area), m	Area conserved, sq.m
1	C	8	2.6	OB	0.4	(0.25)	0	0	110	8	(880)
2	C	5	1.8	C	0.4	0.3	0.4	54	180	27	4,860
3	C	8	2.3	C	0.5	0.4	0.45	103	258	20	5,160
4	C	8	1.8	C	0.5	0	0.3	0	273	26	7,098
5	C	5	1.5	C	0.5	0.3	0.4	114	285	22	6,270
6	C	11	1.7	C	0.3	0.4	0.4	119	297	28	8,316
7	C	7	1.6	R	0.2	0.4+0.4	0.6	240	300	24	7,200
8	C	5	1.6	R	1.0	0.3+0.4	0.8	207	296	17	5,032
9	C	5	1.8	R	1.0	0.3+0.4	0.8	172	245	23	5,635
10	C	5	1.8	R	1.0	0.2+0.3	0.8	133	265	17	4,505
						<b>Total</b>	<b>1,142</b>	<b>2,509</b>	<b>2,509</b>	<b>554,956</b>	

**Types of terraces:**

- OB = old bench terrace
- C = channel terrace
- R = ridge terrace (with two channels)

**Total cost of the terracing ₱ 5,088**  
**Cost per m ₱ 2.03**  
**per cu.m ₱ 4.56**  
**per acre ₱ 375**

Farm No. 3

Terracing by hand

Excavated cross-section 0.5 sq.m  
Length of 25 feet (7.5 m) at a cost of 12 Shs  
Excavated volume 4.28 cu.m per 7.5 m

Cost per m 1.60 Shs  
per cu.m 2.80 Shs  
per acre using total volumes and areas on Farm No. 1  
= 244 cu.m x 2.80 Shs/cu.m = 683 Shs  
divided by (6,395 sq.m : 4,047 sq.m =) 1.6 acres =  
427 Shs/acre  
per acre using total volumes and areas on Farm No. 2  
= 1,142 cu.m x 2.80 Shs/cu.m = 3,198 Shs  
divided by (54,956 sq.m : 4,047 sq.m =) 13.6 acres =  
235 Shs/acre

Farm No. 4

Terracing by hand

Excavated cross-section 0.6 sq.m  
Length of 25 feet (7.5 m) at a cost of 17.50 Shs  
Excavated volume 4.50 cu.m per 7.5 m

Cost per m 2.33 Shs  
per cu.m 3.89 Shs  
per acre using total volumes and areas on Farm No. 1  
= 244 cu.m x 3.89 Shs/cu.m = 948 Shs  
divided by (6,395 sq.m : 4,047 sq.m =) 1.6 acres =  
593 Shs /acre  
per acre using total volumes and areas on Farm No. 2  
= 1,142 cu.m x 3.89 Shs/cu.m = 4,442 Shs  
divided by (54,956 sq.m : 4,047 sq.m =) 13.6 acres =  
327 Shs/acre

SOME ASPECTS OF THE SOIL CONSERVATION POLICY OF THE MINISTRY  
OF AGRICULTURE

In many parts of Kenya, soil is lost or fertility reduced because of the accelerating soil erosion and neglected maintenance of existing soil conservation. Before intensified soil conservation started, more terraces disappeared every year than were constructed. On cleared land, most of it on steep slopes, there was normally no terracing.

The Ministry of Agriculture has studied the present situation in order to formulate the most suitable approach. The Programme produced, aims at:

- strengthening soil conservation in the general extension package
- closer supervision of extension staff in relation to their promotion of soil conservation
- an individual approach by extension staff to the farmers (especially during the off-season as this is the time to engage in soil conservation)
- public responsibility for soil conservation works which go beyond the landowner's responsibility (e.g. large cutoff drains on slopes and diversion ditches for gullies).

Because of the large number of farms needing soil conservation it is impossible for the Government to pay for or subsidize soil conservation measures on individual farms. The farmers have to carry out the necessary soil conservation measures by their own effort, by workers paid by them or by loans. A Governmental or District contribution to individual farms should be given only in rare exceptions, e.g. one single farm for demonstration purposes.

The main contribution of the Government should be the necessary cutoff drains, which will take care of water coming from areas outside the farms, e.g. large hill-sides, human and stock paths, road ditches and market places. These would be beyond the financial capacity of most farmers. Such measures would also require advice from the technical staff and organizational aid from the administration. Long slopes with terraces may also need cutoff drains, if flows pass from farm to farm.

Artificial waterways taking care of water from terraces and cutoff drains might be considered as an extension of cutoff drain work, and therefore subsidized by Governmental or District funds, if available.

Thus there would be a clear definition of responsibilities in the national soil conservation programme. Terraces and similar measures on individual farms would be paid for by the farmers, and cutoff drains taking care of water from areas outside those farms, or water from several farms on long slopes, would be subsidized by Governmental or District funds, if available.

The importance of contributing only the cost of cutoff drains (and waterways) from Governmental or District funds is evident from the following examples. On a slope of 16 %, the cost of terracing one single farm of 6 acres can be better used for cutoff drains benefiting 21 farms. If the slope was steep, e.g. 32 %, you could construct cutoff drains for 43 farms instead of terracing only a single one.

How the figures have been calculated can be seen from the following two tables:

Area of farms		Length of terracing	
in acres	in sq.m	slope 16 %	slope 32 %
		(V.I. 1.8 m) (H.I. 11 m)	(V.I. 1.8 m) (H.I. 5.5 m)
2	8,094	738	1,472
6	24,282	2,208	4,416
8	40,470	3,679	7,358

If the widths of the farms (measured along the contour) is 50, 100 and 150 m respectively, one could construct cutoff drains for the following number of farms, compared to terracing only one farm:

Area of farms in acres	Width of farms in m	The figures below show how many farms with cutoff drains correspond to terracing only one farm	
		slope 16 %	slope 32 %
2	50	13	28
6	100	21	43
10	150	23	48

Previously the allocation of subsidies for soil conservation was confusing as is shown in the following three examples:

- 1) In one location all terracing was paid for by the District Development Committee (the paid workers doing this soil conservation work should indeed not be called "self-help groups").

- 2) In a near-by location Governmental funds were available only for cutoff drains.
- 3) In a neighbouring settlement area no contributions at all were made by the Government towards the soil conservation work. Consequently the farmers refused to do anything.

The system of subsidizing all soil conservation including terraces does indeed often do more to prevent rather than encourage soil conservation. The farmers sit down and wait for the Government to come and do the soil conservation for them. However, the policy in line with example 2 above does bring benefit to many farmers, and does encourage them to do their terracing on an individual basis.

IV SOIL CONSERVATION ON GRAZING LAND

C O N T E N T S

	pages
1. Introduction	109
2. Development of erosion on grazing land	109
3. Measures	
Closing an area	110
Closing and reseeding	110, 113
4. Difficulties, and how to begin tackling them	112



## INTRODUCTION

We have been dealing with erosion and soil conservation on cultivated land. This is only one side of the coin. The other side is erosion on grazing land. Such land is not under crop because it is not good enough: stony, shallow soil, infertile and/or low rainfall. Mismanagement through overstocking and overgrazing often produces a poor grass cover and accelerating erosion. This problem is more serious in dry areas than in the high potential areas with large annual rainfall.

There are no figures for the soil loss from overgrazed and bare ground, but there are figures from fallow ground and these are very high. Indeed erosion in overgrazed areas is larger than that on cultivated land.

## DEVELOPMENT OF EROSION ON GRAZING LAND

How the erosion develops is well known. Overgrazing, in combination with droughts, causes bare spots increasing in size. Perennial grasses are replaced by annual grasses and coarse weeds. The trampling of cattle year after year compacts the surface of the bare ground. The rain water does not infiltrate into the soil but runs off on the surface. Rain and rill erosion remove the topsoil. The bare roots of trees and bushes indicate the rate of erosion during the last years or decades.

The gully erosion starts. The gullies cut deeper down to the bedrock and backwards to the solid rocks of the hills, or their crests. The land will be dissected by more or less parallel gullies. Later on branches develop from the gullies so that they will form a treelike ramification. This is the final stage and the definite end to cultivation and good grazing.

Such "badlands" exist, especially in the semi-arid zones around and below the highlands. In this border zone there are highly erodible silt and sandy soils, which have been deposited by the water flows from the highlands.

## MEASURES

The most important soil conservation measure in such areas is grazing control (destocking, if necessary, and rotational grazing). Deep and loamy soils (sandy loam, silt loam and loam) are best suited for rehabilitation. The rainfall should preferably be more than 300 mm/year.

Rehabilitation should start with:

- 1) closing the area to grazing and thereby allowing natural grasses to establish a cover all over the ground (grazing control) or
  - 2) reseeding with suitable species of grasses, after some land preparation (vegetation modification).
- 1) Closing an area

To increase the infiltration, ploughing can be done along the contour (horizontally), thereby retaining the water. There can be a spacing of one to three metres between the plough furrows (pasture furrows), one metre on completely denuded land and three metres in areas with some grass and weeds. Pasture furrows can decrease runoff by 40 % and erosion by 90 %.

Burning the area is recommended as soon as sufficient combustible vegetation is available.

### 2) Closing and reseeding

Usually scratch ploughing, by ox-plough or jembe, is needed. Harrowing after seeding should not be done except in areas of high rainfall.

As to the time of seeding it is best to reseed at the beginning of a rainy season and preferably that one followed by the less pronounced dry season, if there are two dry seasons.

About 100 seeds per square metre are needed for broadcasting by hand, as the germination rate is often only 10 %. However, the rate varies for different species.

Perennial grasses should be used, as they usually live for up to 6 years. In drier climatic zones the proportion of annual grasses increases, and below 250 mm of annual rainfall no perennial grasses survive. The table on the next page shows recommended species for different natural conditions in medium and low potential areas (mainly after Bogdan and Pratt).

Annual rainfall requirement in mm	Species of grass	Illustration reference in Appendix 2	Soils preferred	Occurrence in Kenya (m = metres above sea-level)	Seed rate per acre
750 or more	<i>Cynodon dactylon</i> (Star Grass)	p.2	Sand and silt	Up to 2,400 m	5-8 oz.
	<i>Panicum coloratum</i> (Coloured Guinea Grass)	p.4	Best on heavy soils but also on light	Northern and southeastern Kenya	1 lb.
700-600	<i>Chloris gayana</i> (Rhodes Grass)	p.2	Loam, silt, sand but not heavy clay	Most important pasture grass, common 600-2,100 m	8 oz.
	<i>Panicum maximum</i> (Guinea Grass)	p.5	Sand, silt, loam	Common in all semi-arid areas	1-1.5 lb.
	<i>Themeda triandra</i> (Red Oat Grass)	p.6	Sand and loam, black cotton soil	Above 1,500 m	5 oz.
700-500	<i>Panicum coloratum</i> var. <i>macaricariense</i> (Marikari Grass)		Best on heavy soils but also light	Especially Kitui and Machakos Districts	1 lb.
700-450	<i>Cenchrus ciliaris</i> (Buffel Grass)	p.2	Sand, silt, loam	Widespread in dry areas	2.5-3 lb.
600-550	<i>Eragrostis superba</i> (Masai Lovegrass)	p.3	Sand and loam	Below 2,000 m, e.g. Kitui and Machakos Districts	10 lb.
	<i>Enteropogon machrostachyus</i> (Bush Rye)	p.3	Sand and loam, also rocky ground	300-1,500 m, e.g. Baringo District	6 lb.
500	<i>Eragrostis caespitosa</i> (Cushion Lovegrass)		Poor sand	Up to 1,500 m, e.g. from Yatta Plateau to Embu	0.5 oz.
300-200	<i>Eragrostis cilianensis</i> (Grey Lovegrass)	p.3	Alluvial soils	Northern Kenya	2 oz.
	<i>Latipes senegalensis</i> (Hook Grass)	p.4	Also on eroded slopes and rocky ground	Found in Machakos District and towards Voi	3 lb.

## DIFFICULTIES AND HOW TO BEGIN TACKLING THEM

To support one livestock unit during one year one needs:

- 1) 4 acres of unimproved natural grazing, or
- 2) 3 acres of improved natural grazing, or
- 3) 2 acres of good grass ley and napier grass.

These figures from South Nyanza show how important an improvement of the pasture is. It is not true to say that destocking is always needed.

Although the methods of preventing erosion and creating good pastures are known, grazing control and reseedling have not been introduced very much. There are several reasons for this. Most grazing land is communal without any rules. One of the reasons on small-scale farms is lack of money to pay for fencing and to buy grade cattle to utilize fully an improved pasture. Another reason is the inexperience of farmers in managing grade cattle; with yet a fourth reason being the long distances to water supplies for grade cattle.

To emerge from the present conditions first steps have to be taken somewhere on small-scale farms. Figure 20 on page 113, plus its text, explains how to begin.

On communal land there are difficulties in fencing areas for establishing better grass, and having these areas respected by more or less nomadic people. However, an example from Laikipia District shows that it is possible to rehabilitate communal grazing land. At Dol Dol the Agricultural Range Officer in co-operation with the chief has closed grazing areas for about 3 months, followed by grazing for a period, the length of which depends on the local conditions, e.g. grazing only permitted for 6 months.

On grazing land with unreliable rainfall the main difficulty of course is drought. Fodder trees can serve as reserves, as well as protection from erosion. Examples of fodder trees are Leucaena, Prosopis and Acacia albida (see Chapter V, p. 116, 121 and 122).

A farm with a cultivated, terraced upper slope and an overgrazed, gully eroded lower slope

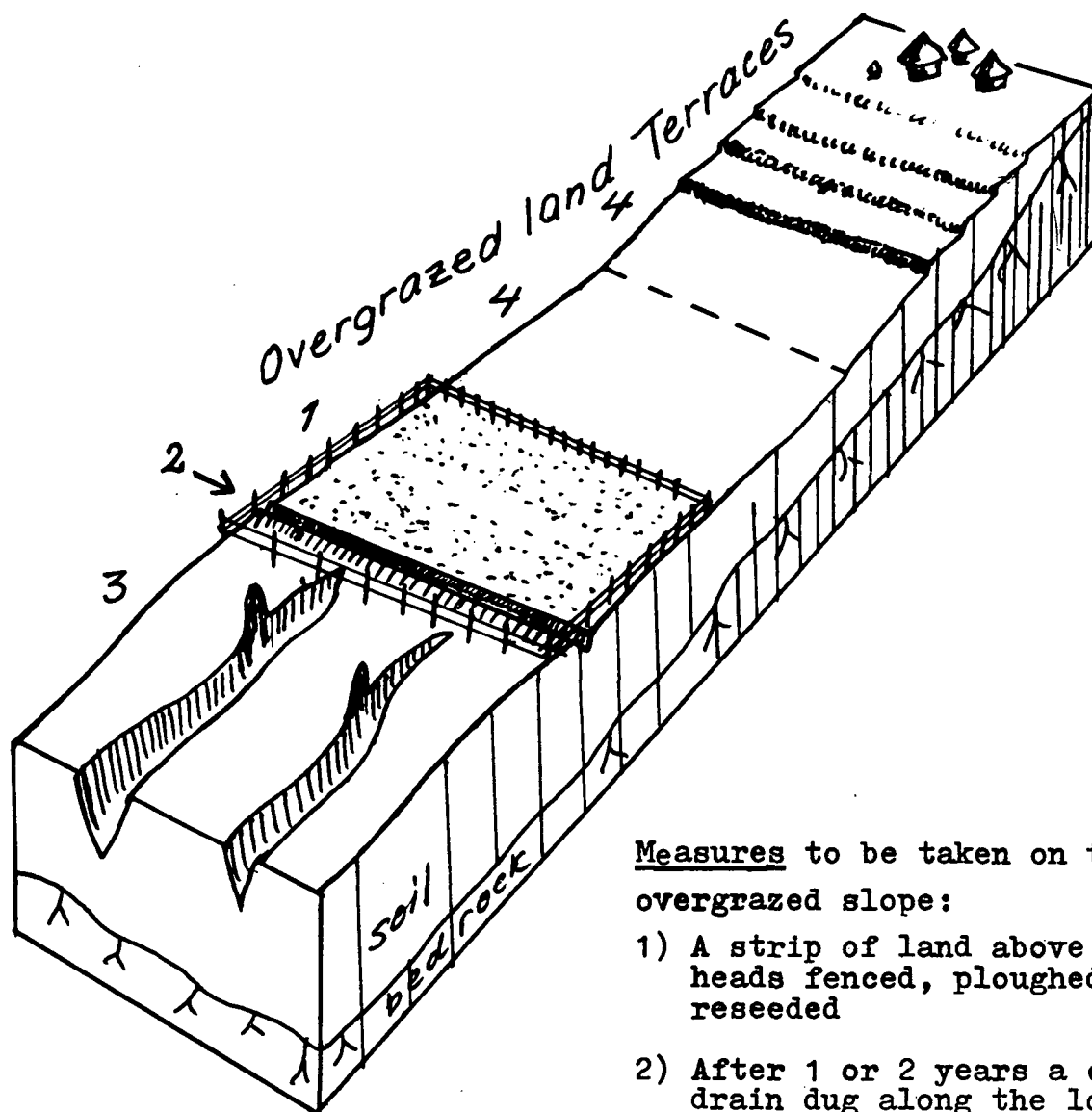

Measures to be taken on the overgrazed slope:

- 1) A strip of land above the gully heads fenced, ploughed and reseeded
- 2) After 1 or 2 years a cutoff drain dug along the lower side of the paddock, if needed
- 3) Area round the gullies closed to grazing, alternatively also reseeded
- 4) Establishment of other strips (blocks), one by one for rotational grazing
- 5) Control measures against erosion in the gullies, if necessary (see Gully control, p. 9-10)

Two rules to remember:

- 1) Measures against erosion without grazing control are useless
- 2) Cutoff drains, especially in silt and sandy soils, are useless without grazing control and establishment of grass cover on the ground round the gullies.

V AGRO - FORESTRY

C O N T E N T S

	pages
1. Introduction	115 - 116
2. When to recommend trees	116
On parts of farms not suitable for crop production	117
In reclamation of eroded land including gullies	117 - 118
On river banks	118
Along cutoff drains and terraces	118 - 121
In semi-arid areas	121 - 121 a
Shade trees	121 a
Wind breaks	121 a
Ornamental trees	121 a
3. Selection of trees	121 a - 122

## INTRODUCTION

Agro-forestry is a productive system combining agricultural crops and/or cattle with the planting of trees.

Trees are important in soil conservation and in the rehabilitation of eroded areas. At a show in Nairobi in 1977, arranged by the International Development Research Centre (of Canada), Mr. Gunnar Poulsen expressed the importance of trees in the following way: "Trees help to maintain a favourable climate, prevent or reduce wind and water erosion, provide favourable conditions for the cycling of soil nutrients, add humus and nitrogen to the soil — thereby improving both structure and fertility — produce buds, leaves and fruits that are consumed by livestock and humans, provide the ideal environment for wildlife, carry the flowers that are the main source of honey on this continent — apart from yielding the "usual" forest products: timber and ecudates. If the African environment is to be developed for the benefit of man, the three basic land uses — crop farming, animal husbandry and forestry — must be integrated to a much larger extent than they are now."

It should be added that the tree resources of Kenya are still decreasing and for this reason the introduction of more trees onto farms is essential. To farmers trees mean increased total yields.

Growing certain trees and ground crops together can be the best means of preserving the fertility and structure of the soil. As an example we can take a farmer in Mitaboni Location in Machakos District (north of Ngelani Market). He has peach trees along the edges of his bench terraces. The annual sales value of the peaches from the terrace edges is greater than that of the maize on the bench terraces. The farmer says that the yield of the maize under the peach trees is higher than that on the bench terraces without trees. He thinks that the reason is that the soil below the tree is more fertile.

Fodder trees, supplying cattle with leaves during droughts, can also have high food yields, e.g. bean-bearing trees such as algaroba can produce 2-10 tons/acre. The protein content of the fruit varies between 15 and 25 %, compared with 6-14 % in common cereals.

Trees suitable for agriculture can be grouped in the following way:

- 1) timber and fuel trees
- 2) fruit trees and bananas
  - a) fruit-bearing, e.g. citrus and mango
  - b) nut-bearing, e.g. macadamia and cashew-nut
  - c) oil producing, e.g. coconut
  - d) tree legumes, e.g. lucena and algaroba
- 3) fodder trees, e.g. Acacia albida and algaroba

Many trees can be classified as belonging to more than one group.

Examples:

Leucaena leucocephala (previously = *glauca*) (Lucena) is a quick-growing fodder tree (4.5-6 m high) with deep roots. Fodder can be cut every 6-8 weeks, giving 40 tons/acre/year of palatable green feed, equivalent to 10 tons of hay. Lucena has been interplanted with maize for many hundreds of years by the Maya-Indians of Central America. The fruit can be eaten by cattle and humans. The timber is good for fuel, and in forests it produces up to 13 cu.m/acre/year. Lucena will produce pods 8 months after planting, and good pulpwood after 3 years.

Prosopis juliflora and P. chilensis (Algaroba) both represent a drought-resistant, medium-sized tree, stabilizing and acting as a bio-fertilizer. The roots grow to a great depth. The wood gives fuel, the lumber poles. Algaroba will produce beans after 2 years. The average annual yield is 1.6 tons/acre/year. After 3-4 years the height will be 9 m. In Kenya, the tree can be seen growing at Kanga Railway Station and in the Bamburi Cement Quarry. As algaroba has a high potential for reclaiming arid and semi-arid areas, district nurseries concerned have been provided with seeds.

#### WHEN TO RECOMMEND TREES

In agriculture trees are needed in the following circumstances:

- 1) Parts of farms not suitable for crop production
- 2) Rehabilitation of eroded land including gullies
- 3) On river banks to prevent erosion
- 4) Along cutoff drains and terraces
- 5) In semi-arid and arid areas as fodder trees
- 6) As shade trees in grazing areas
- 7) As windbreaks
- 8) As ornamental trees in homesteads.



1. Parts of farms not suitable for crop production

Even shallow and poor soils can carry a luxuriant forest. The reason being that trees have a network of roots, which absorb the nutrients of the ground very well. Less is leached out compared with crop land. Trees also return their absorbed nutrients through the production of leaves, branches and fruits falling down to the ground. Thus a new topsoil is created. Tree roots can also make moisture and nutrients available from greater depths than plants. If trees are cut, the poor, leached conditions of a treeless soil will return after a few years.

Natural savannah and woodland produce timber at the rate of 0.5-2 cu.m/acre/year, but planted trees can produce firewood and timber at a rate 10 times greater.

Different trees have different planting distances, and the number of planted trees in an acre of forest (dependent on the spacing) can be seen from the table below:

Distance apart in feet	Number of plants per acre	Distance apart in feet	Number of plants per acre	Distance apart in feet	Number of plants per acre
1	43,560	10	537	22	90
1.5	19,360	11	435	24	75
2	10,890	12	302	26	61
2.5	6,970	13	257	28	55
3	4,840	14	222	30	48
3.5	3,556	15	193	32	42
4	2,722	16	170	35	35
5	1,742	17	150	37	32
6	1,210	18	134	40	27
7	1,037	19	120	45	21
8	889	20	108	50	18
9	680				

2. Rehabilitation of eroded land including gullies

Trees reduce soil erosion on slopes and stabilize the slopes because:

- 1) they prevent raindrop erosion,
- 2) their canopies and the litter produced on the ground can trap up to 20 mm of continuous rainfall, thus reducing rill erosion and solifluction (see pp. 6 and 14), and
- 3) in the ground below the forest the rates of infiltration and percolation are much greater than in cultivated ground.

Trees cover the ground with litter. From the paragraph above it can be understood that a plantation of trees on badly eroded land can restore the topsoil and the productive conditions of

the soil. Leaves etc. falling from the trees will start a slow but steady formation of humus, on which all soil improvement depends.

Example:

Eucalyptus species are recommended on overgrazed hills with shallow poor soils. On eroded ground alternating rows of Eucalyptus and Acacia (fixing nitrogen) are recommended.

Tree belts along the contour occupying only 6 % of a hill area, can halve the overland flow, and 30-40 % covered by forest belts can absorb the entire overland flow (Pereira 1973). This means that it is not always necessary to do reforestation all over a hill. Some shambas with bench terraces can be left in the forest, This should occupy rocky and steep slopes as well as areas with a thin layer of soil on the bedrock.

As to the reclamation of overgrazed and eroded pastures see p. 110, 112-113 and for gully control see as well p. 9-10 and Appendix 1.

### 3. On river banks to prevent erosion

Bushes and tall grass reduce the velocity of water over flooded ground. As to the need for trees the following can be said:

- 1) If the depth of the water is greater than the root systems of the trees (usually a depth of more than 1-2 m), these can do little to protect the bank from erosion.
- 2) If the root systems of the trees reach deeper than the bottom of the river, they can delay the erosion of steep banks, usually situated in the bends of a river.

However, along small watercourses strips of grass 0.5 m wide, on both sides, give better protection against erosion than the trunks and roots of trees.

### 4. Along cutoff drains and terraces

In this case trees can be planted in different ways (see Fig. 21 next page).

- 1) The usual way is to plant on the upper side of the grass strip or embankment (Fig. 21:1).
- 2) In dry areas trees and preferably bananas can be planted in pits below the bank of the terrace, in "silt pits", collecting water and silt (Fig. 21:2). The latter must be removed from time to time and put on the grass strip (embankment).
- 3) On steep slopes, i.e. between 25% and 55%, modified bench terraces can be used for trees (Fig. 21:3). Narrow benches

F1 Trees planted  
1) on grass strips, 2) in silt pits  
and 3) on modified bench terraces

1) on an embankment



2) in a silt pit

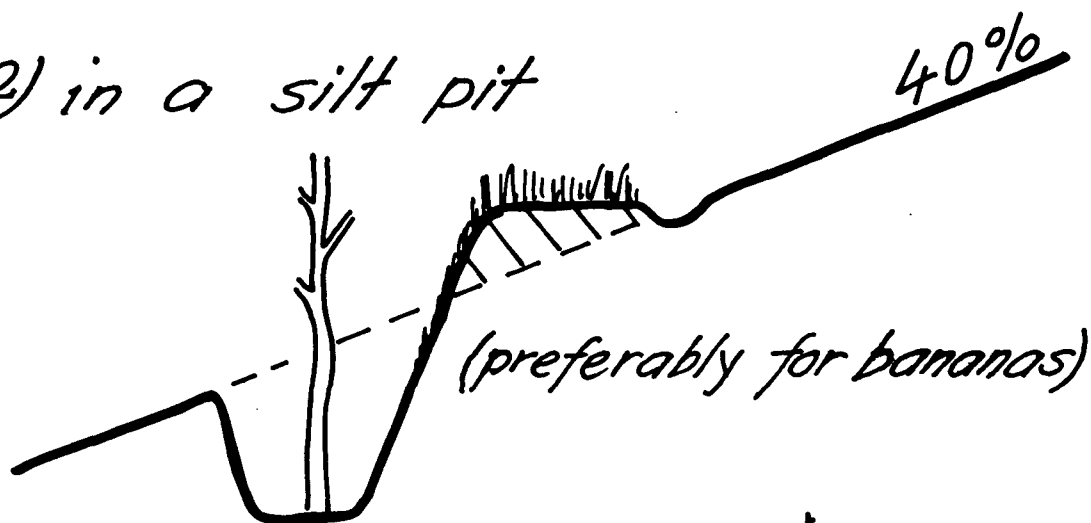

3) on modified bench terraces

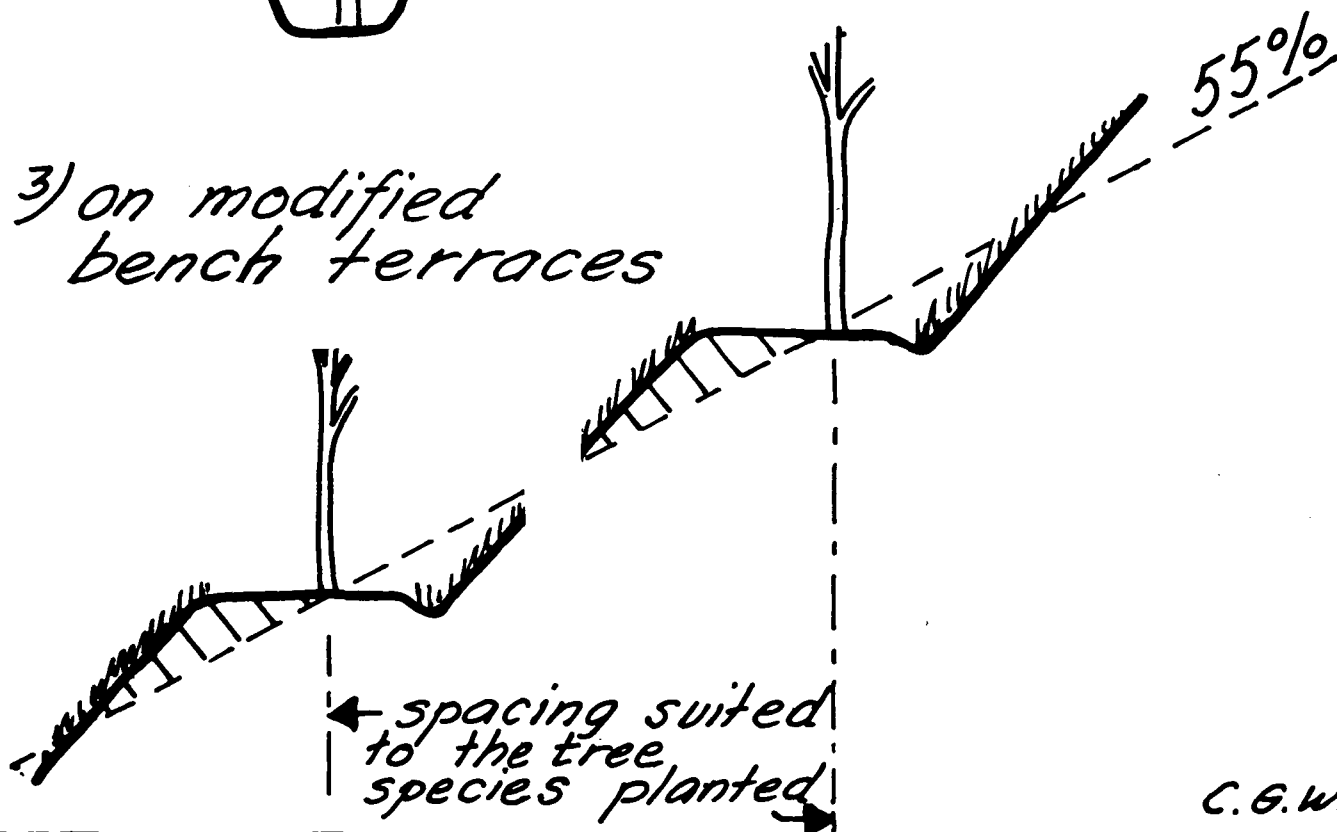

C.G.W.

Tree planted  
on individual modified bench terrace

4) on an individual  
modified bench terrace

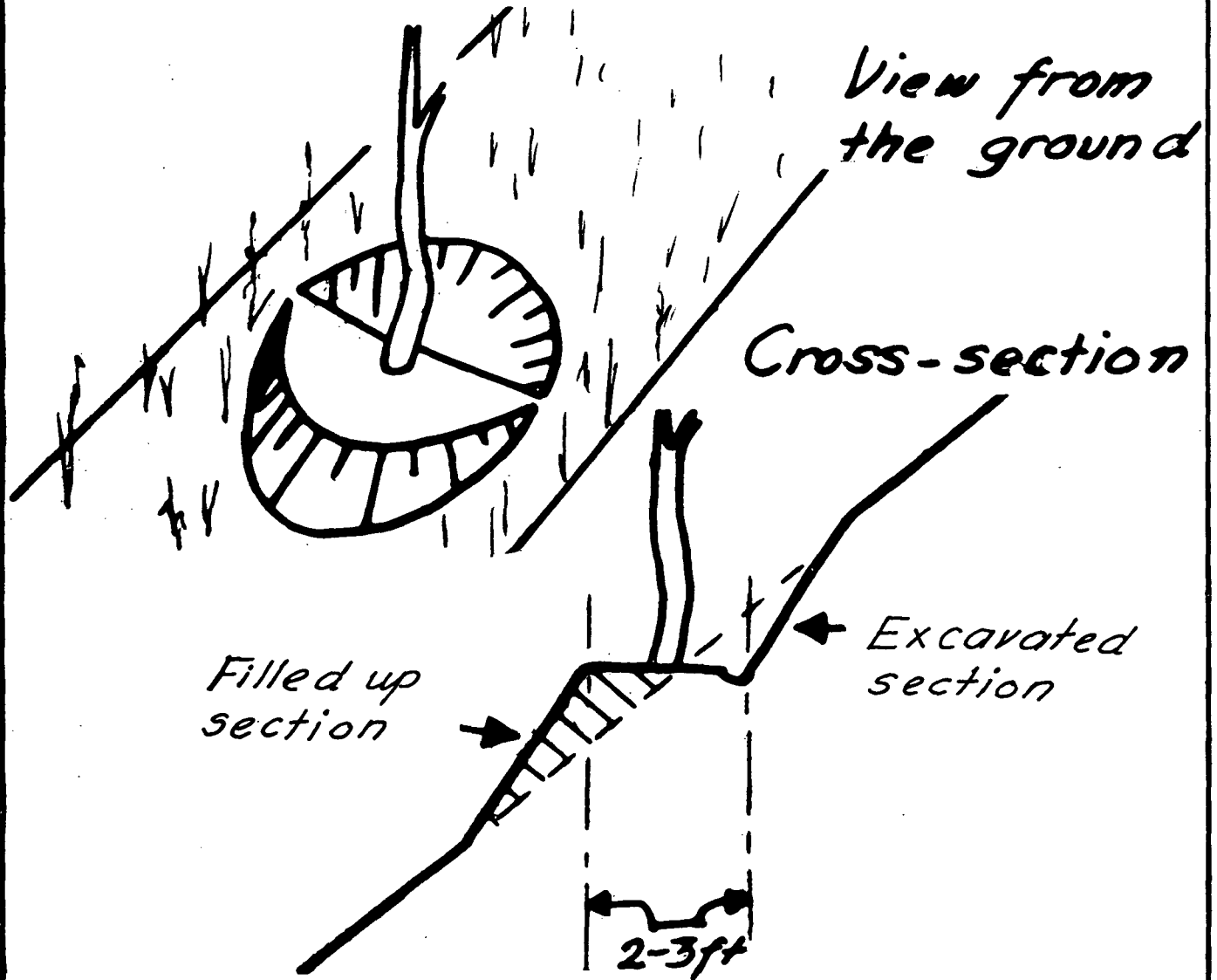

with small ditches should be excavated, and the excavated soil should be used to widen the bench. The trees should be planted in the middle of the bench, and grass planted on the slopes between the terraces as soon as possible.

- 4) Modified bench terraces can be split up into individual modified bench terraces, i.e. a small step for every tree planted (Fig. 22, above).

Trees suitable for the embankments of cutoff drains and the edges of terraces:

- 1) Fruit trees, e.g. peaches, citrus and coco nuts , but not guava, mangoes or cashew. Bananas are very suitable as their root activity is highest within 1 m distance from the stem.
- 2) Fodder trees in semi-arid areas (see below), e.g. *Acacia albida*, *Cassia siamea* and the neem tree.
- 3) Timber trees, e.g. *Grevillea robusta*, *Casuarina equisetifolia* and *Pinus patula*, but not *Cupressus* and *Eucalyptus*.

More knowledge is needed as to the suitability of different tree species for planting along terraces. Anyhow the yield from trees and crops together is higher than from crops only.

#### 5. Semi-arid areas

It probably sounds a bit curious to say that the drier the climate, the more essential it is to have trees. But the reason is that there is a need for trees in the semi-arid areas to provide cattle with fodder, especially during droughts. Trees are also needed in semi-arid areas for other purposes:

- 1) minimizing wind- and raindrop erosion
- 2) increasing fertility by bringing up nutrients from great root depths ("nutrient pumps") and returning them to the ground as litter
- 3) preserving the vegetation cover through shade, which will help to maintain a better microclimate, thus permitting humus generation instead of humus reduction
- 4) restoring hydrological conditions, and
- 5) providing fuel, wood and timber.

If the trees or their leaves are likely to be eaten by cattle, the young trees must be protected for at least 2 - 5 years.

The soils can have a low nutrient content, but must not be too shallow, because the prerequisite for trees in semi-arid areas is sufficient depth for a deep rooting system.

Examples:

*Acacia albida* (Apple Ring *Acacia*) grows on sandy soil throughout Kenya. This tree sheds its leaves at the beginning of the rainy season and develops a canopy during the dry season, thus being an ideal fodder tree. The trunk can reach a height of 20 m and have a diameter of 1 metre. A rotation for timber is 30 - 40 years. Its main use, however, is to fertilize and restore the soil cultivated in the shade of the tree.

Scientific investigations in Senegal (Charreau and Vidal) have shown that soil properties as moisture and humus are improved under *Acacia albida* trees. The fertility is improved through increased rates of nutrients (nitrogen, available phosphorus, exchangeable calcium, and exchangeable base sum). There is a close relationship between most minerals in the leaves and those in the ground below. This improvement in soil properties increases from the

the periphery of the canopy towards the trunk. The seed and protein yields of millet when grown under trees are increased by 50 - 300 %.

Leucaena leucocephala and Prosopis juliflora (p.116) can also be used for rehabilitation of desertificated areas. On grassland in an arid area of Arizona (annual rainfall 330 mm) the ground under the canopies of Prosopis trees had dense stands of perennial grasses (24 % covered, biomass 1,146 kg/ha compared with the areas outside the canopies: 4 % covered, biomass 239 kg/ha).

#### 6. Shade trees

If possible shade trees should be on higher parts of the farm rather than along watercourses, because manure from resting cattle will be better distributed with rain water flows. Examples: Croton megalocarpus, Ficus species and Schinus molle.

#### 7. Windbreaks

In dry areas windbreaks and shelter belts also provide shade, fodder and fuel. Thus it is convenient to have more than one row of trees. To protect cattle from strong winds, windbreaks should be planted forming a U or a V, with the open end on the leeward side.

Shelterbelts of one to six rows of Cassia siamea trees were planted on the wind swept plains of Cameroon. Altogether 300 km were planted in four years. After six years the trees had a height of 8 m. Four rows of trees with spacing of 3 m were recommended. Cassia siamea was selected as this tree is not eaten by termites (Guiscafré 1961).

Other tree species for windbreaks in dry areas are Eucalyptus camaldulensis, Casuarina, Conocarpus and the neem tree. The lower branches of young trees should be pruned to encourage straight and tall trunks.

#### 8. Ornamental trees

A farm with ornamental trees becomes a pleasant environment in which to work. Examples: Cassia (below 1,300 m above sea-level), Camel's Foot (Bauhinia, below 1,900 m), Nandi Flame (Spathodea nilotica, below 2,300 m) and Jacaranda (below 2,300 m).

#### SELECTION OF TREES

The following points should be considered:

- 1) Availability of tree seedlings.
- 2) Need of wood on the farm and marketing facilities.
- 3) Altitude of farm above sea level and climate.
- 4) Soil type and depth of the earth layer above rock.
- 5) Influence on adjacent cultivated land, e.g. deep and limited root systems if planted along cutoff drains and terraces (see p. 121).

Examples of trees for various purposes are given below.

Fruit trees for different climatic zones (tree species in brackets are not ususally recommended along terraces)

- 1) Temperate zone: apples, peaches, pears, plums
- 2) Coffee zone: avocados, bananas, custard apple, (guavas,) limes, loquats, macadamia, (mangoes,) mulberry, oranges, papaya, peaches, pomegranate.
- 3) Cotton zone: (cashew nuts,) dates, macadamia /Coast Province/, (mangoes,) papaya.

Other trees (pages in brackets refer to illustrations in Appendix 3)

Use	Species	Altitude m above sea-level	Annual rainfall mm	Soil etc
Firewood, building poles and windbreaks	Azadirachta indica (Neem) (p.3)	Below 1,200	Above 300	Porous well drained soils
	Cassia siamea (Ironwood) (p.2)	Below 1,300	500- 1,500	Most soils, good drainage
	Casuarina equisetifolia (She-Oak, Muinji) x	Below 1,800	Low	Sandy soils, river banks
	Eucalyptus camaldulensis (Red River Gum)	Lowland	Low	Heavy or rocky soils
	Eucalyptus saligna (Sydney Blue Gum)	Mainly highland	900- 1,300	Preferably good loamy soils
	Schinus molle (Pepper Tree)	Also lowland	Low	Poor soils, slow
Timber trees for sawn wood etc	Croton megalocarpus (Musine, Mukinduri)	1,300- 2,400	1,000- 1,900	
	Cupressus lusitanica (Mexican Cypress)	1,200- 3,000	Above 900	Well aerated soils
	Grevillea robusta (Silky Oak)	1,200- 2,300	1,000- 1,150	Best on deep sandy loam
	Podocarpus gracilior (Podo)	1,300- 2,900	High	Shade tolerant, slow
	Pinus patula (Mexican Pine)	1,800- 2,700	1,000- 1,500	Well drained sandy loam
Fodder trees for cattle in dry areas	Acacia albida x (Apple Ring Acacia)(p.1)	Below 1,800	250-900, best 650	Clay to sand, best deep sand
	Conocarpus lancifolius (Somali Tree)	Below 400	Low	Deep soils and heavy clay
	Gmelina arborea (Melina)	Below 1,200	Above 750	Sandy soils, good drainage
	Leucena leucocephala x (Lucena) (p.1)	Below 1,800	Above 250	Not strongly acid soils
	Prosopis (Algaroba) x (p.2)	Below 1,500	250- 1,250	Also sandy rocky soils

x = Roots with bacteria fixing nitrogen

VI THE AGRICULTURE ACT

C O N T E N T S

	pages
1. Slopes	
Previous rules	124 - 126
Conclusions and amendments	127 - 129
2. Watercourses	
Previous rules	130
Conclusions and amendments	130 - 133
3. The text of the Agriculture Act	133 - 136



The Agriculture Act (Legal Notice No. 26 2nd February 1965) deals with two main erosion problems:

- 1) soil erosion on slopes
- 2) erosion caused by watercourses.

Amendments to the Act have been tested in the Soil Conservation Project from 1975 to 1978. This chapter clarifies the rules and some of the amendments proposed.

## SLOPES

In soil conservation the degree of inclination is expressed as the percentage of slope (= drop in feet in a length of 100 feet) instead of in degrees. How to convert degree of slope into percentage of slope is shown in the table ,Fig. 28, p. 136.

### Previous rules

According to the Agriculture Act of 1965 soil conservation measures are needed on cultivated slopes between 12% and 35%. Below 12 % terraces are not required, and no cultivation is permitted on slopes exceeding 35 %. See the upper part of Fig. 23 on the next page.

### Why 12% ?

The reason why cultivated land with a slope of more than 12% should be conserved is that the soil loss on steeper slopes accelerates to unacceptable values. This is illustrated by the graphs in Fig. 24, p. 126.

However, it should be pointed out that soil conservation measures are needed on slopes of less than 12%, if the soils are erodible, the slopes long and the rainfall intensity high. Regarding this farmers have often terraced land of less than 12%.

### Why 35% ?

No satisfactory explanation has so far been given as to why 35 % has been selected as the upper limit for cultivation. This upper limit differs from country to country. In Kenya the upper limit of 35 %, stated in the Agriculture Act, has not been closely followed. Farmers often cultivate slopes exceeding 35 %, and in some areas farmers have been adjudicated land all of which is steeper than 35 %, sometimes much steeper.

# CULTIVATION OF SLOPES

Fig. 23

Width of terraces (horizontal interval) using a constant "drop" in height (constant vertical interval) of 1.8 m (6 feet).

## a. Previous rules

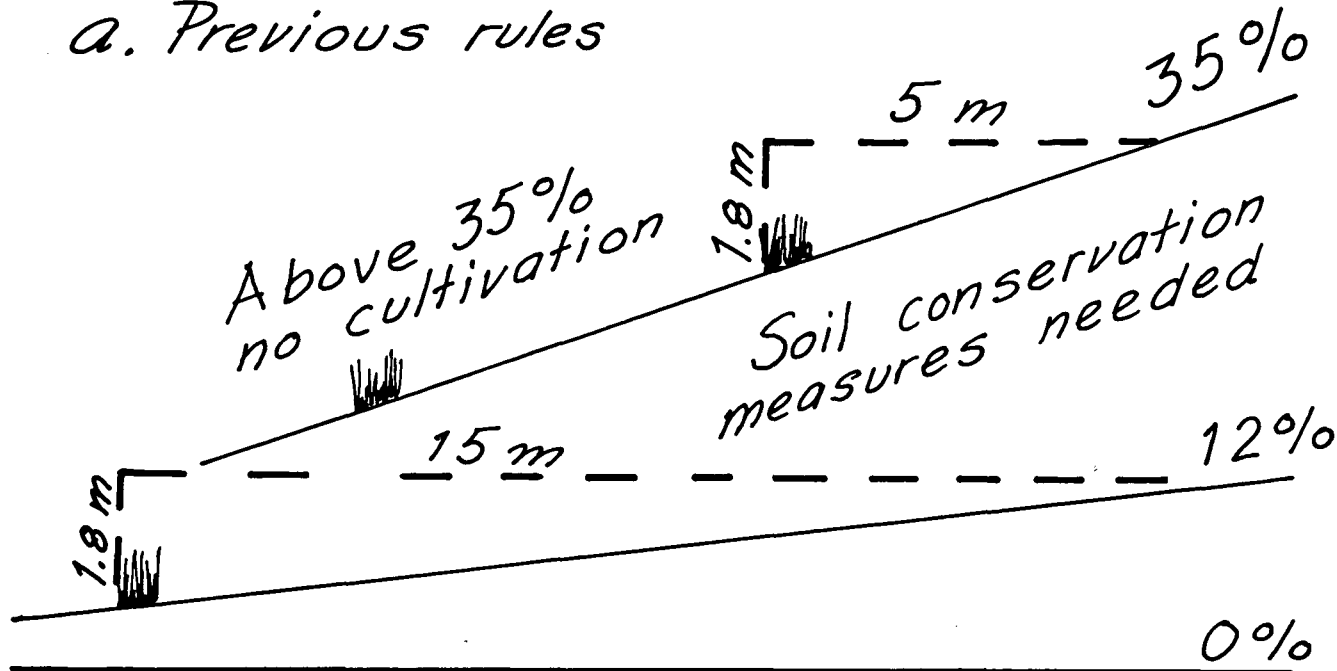

## b. Amendment

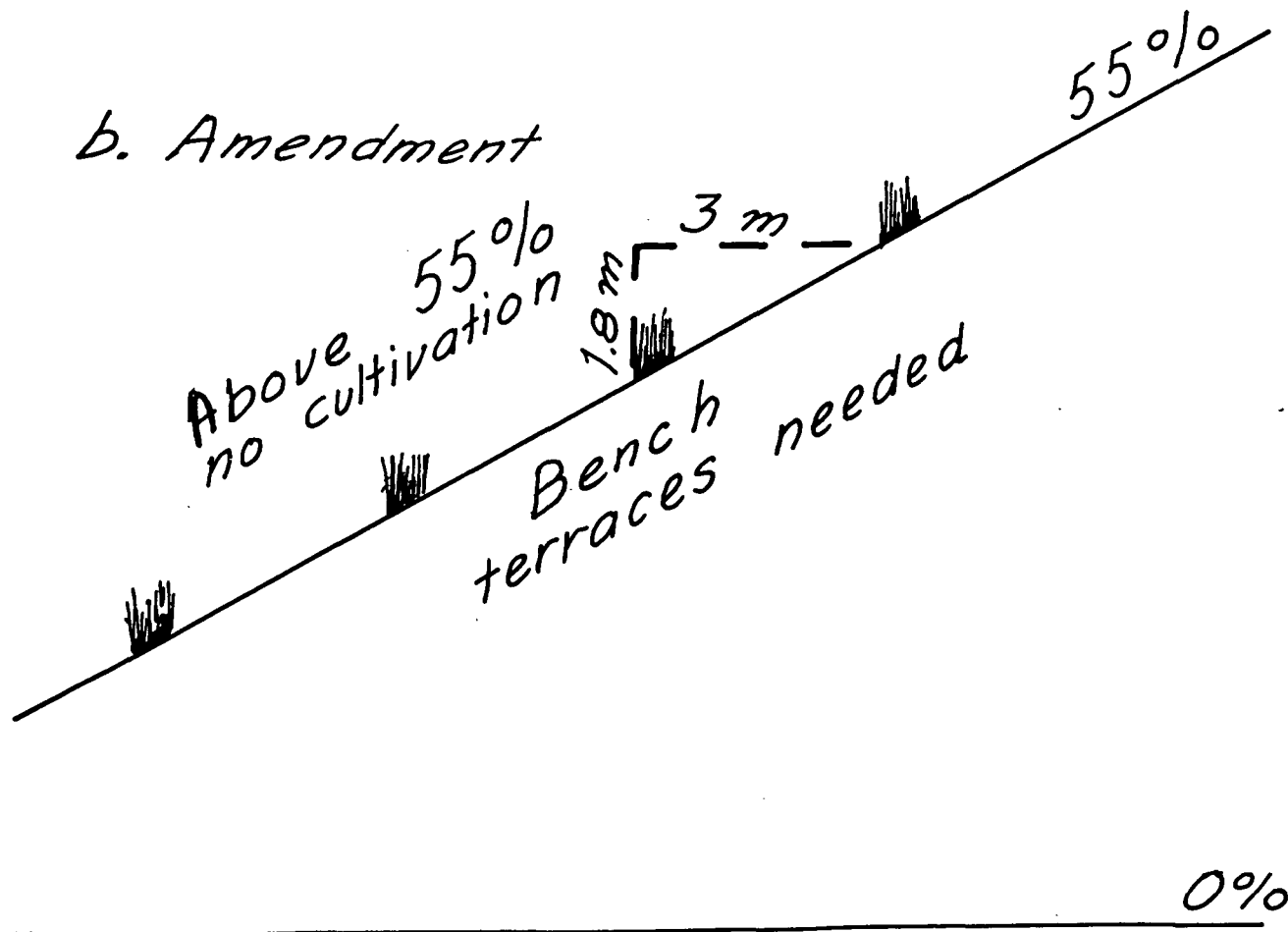

C.G.W.

513 752501 - 113 A4

Graphs showing the increase in annual soil loss with the increase in % slope

Fig. 24

Annual soil loss in tons per acre

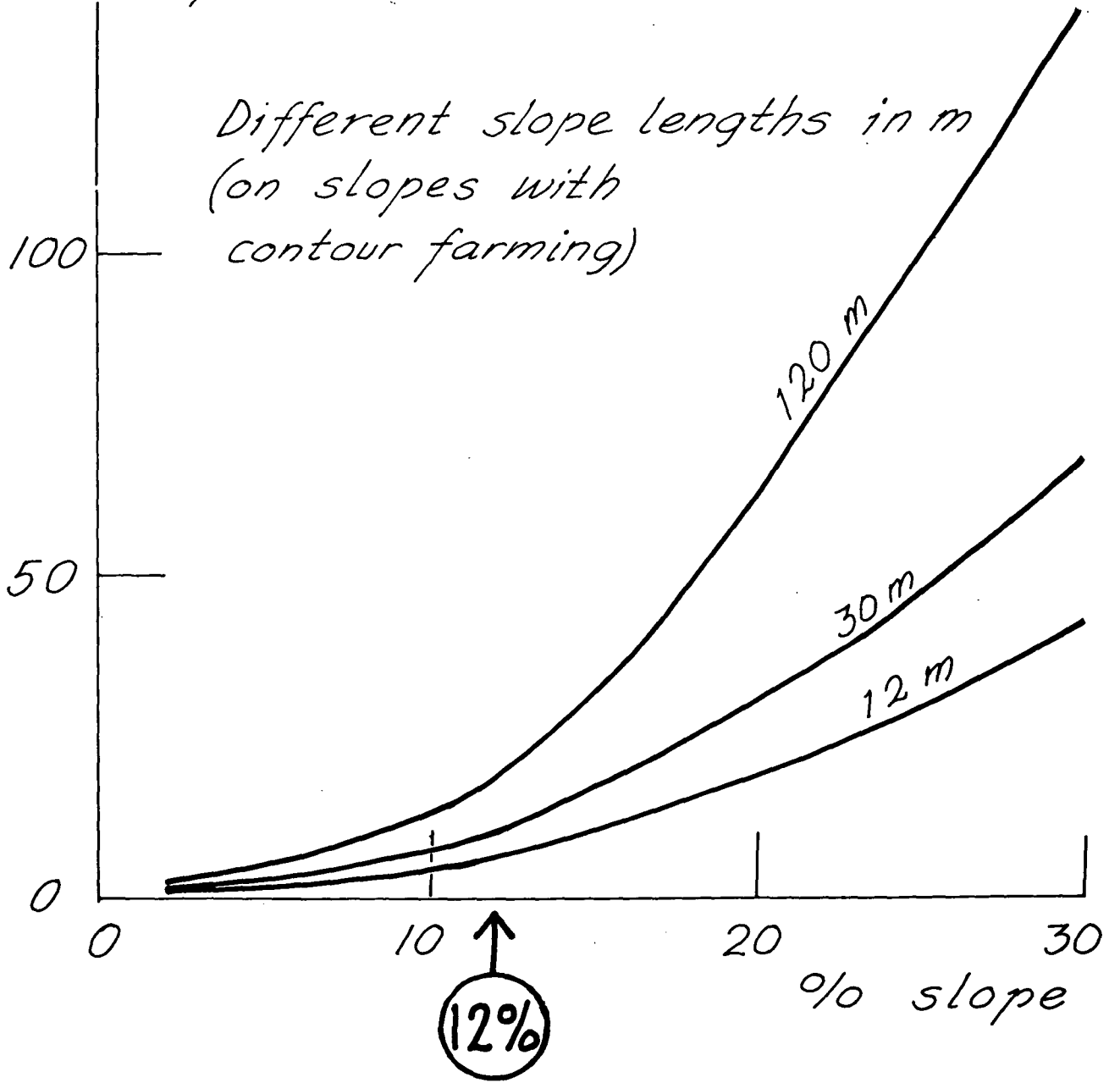

Graphs reproduced from a table in Agricultural Engineer's Handbook, 1961

## Conclusions and proposals for amendments

### Highest percentage of slope for cultivation

On slopes steeper than 35% cultivation is acceptable only if it is carried out on bench terraces (see Fig. 25 a on the next page), but these tend to be high and narrow on very steep slopes. With a vertical interval of 1.8 m (6 feet) the terraces will be less than 3 m (10 feet) wide on a slope exceeding 55% (the lower part of Fig. 23, p. 125). Consequently, it is not usually practicable to use bench terraces on slopes exceeding 55 %, but 55 % itself will give 3 m wide terraces suitable for coffee.

Another reason for using 55% as the upper limit of slope for cultivation is the stability of the slope. Under natural conditions with natural forest or natural grass land, a very steep slope is stable because of the cohesion of the soil. But if you break that ground into clods by cultivation, those clods will not remain on the slope, but will fall down. Compare this with a heap of sand, the slopes of which cannot be steeper than the angle of repose (angle of friction) of the sand, i.e. about 30° or 55-60%. Likewise on steep slopes the particles or clods of soil will not remain on the slope but will fall down automatically. These conditions are illustrated by Fig. 25 c - d on the next page.

Sometimes farmers try to cultivate maize on slopes steeper than 50-60 %. They usually get yields for some years, as long as the topsoil remains. After a few years, e.g. 2-6 years, the erosion will be so significant and the yield so poor, that continued cultivation with maize would be senseless.

Slopes exceeding 55% should have forest or permanent grass. In areas of high rainfall and resultant water pressure in the ground, there is a risk of earth flow and landslides. These are likely to occur in soils of loam and clay on slopes exceeding 60%. On these slopes forest gives a better protection than permanent grass. The reason being that trees absorb more water from the ground than grass.

The conclusion is that 55% (i.e. between 50 and 60%) can be used as an upper limit for cultivation, if bench terraces are used. A prerequisite of bench terraces is that the soil is deep enough for developing the terraces.

Alternatives to bench terrace cropping are: fruit trees on modified bench terraces (Fig. 25 b), tea, bananas and sugar cane with a trash cover on the ground.

CULTIVATION OF SLOPES

Fig. 25

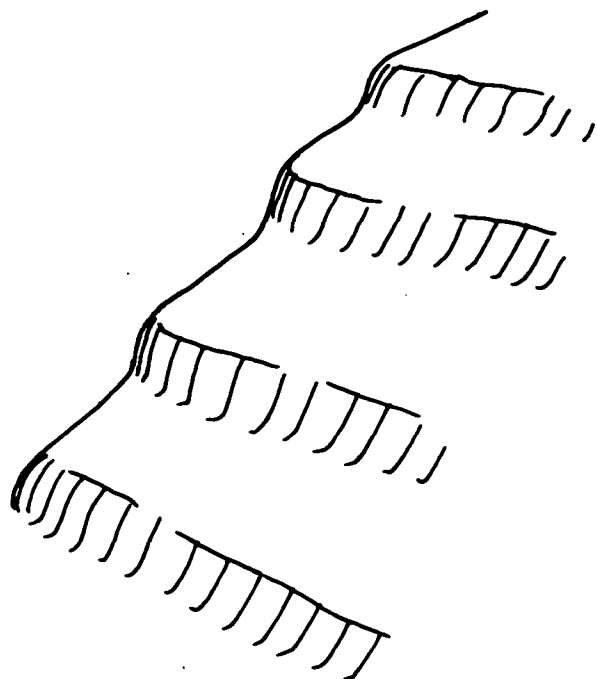

a. Bench terraces  
3 m wide

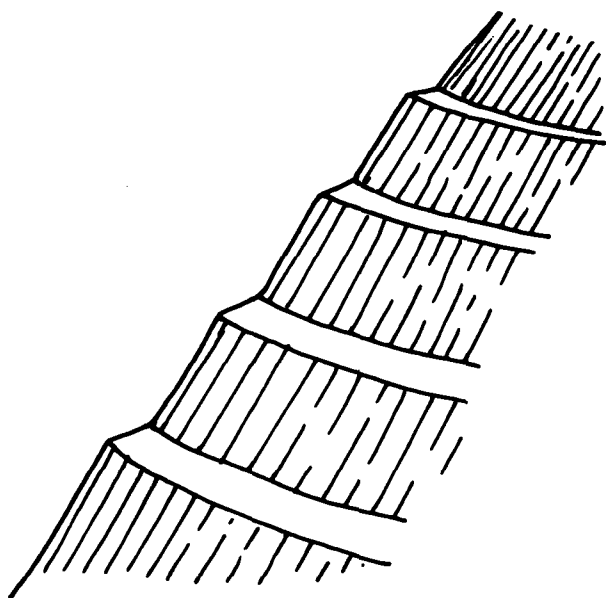

b. Modified  
bench terraces

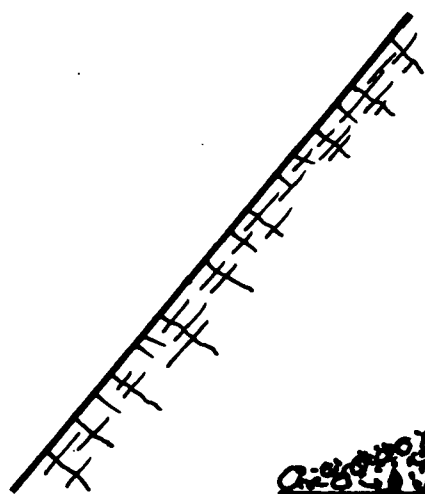

c. Steep slope  
not cultivated,  
stable due to  
cohesion

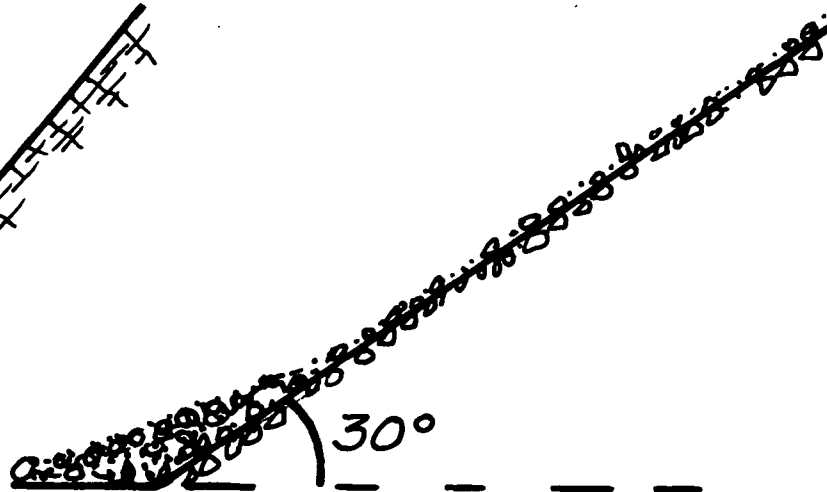

d. Cultivation has  
broken up the  
soil into clods.  
The slope is stable  
at about 30° or  
55-60% c.g.w.

Highest percentage slope possible for cultivation without terracing  
 In the table below I have used the Soil loss equation to calculate the limit for the percentage of slope, where the soil loss is not acceptable. The crop is supposed to be maize as usually cultivated in Kenya, but other factors vary: soil, rainfall intensity and length of slope.

The table aims to show that there is no single figure for the percentage slope, where the soil loss is not acceptable (= more than 5 tons/acre/year). This is because the figures vary with the soils, rainfall intensity and length of slope.

Erodibility (soil)	Rainfall intensity							
	medium (R = 200)				high (R = 500)			
	Length of slope in metres							
	50	100	150	200	50	100	150	200
High (loam)	6	5	4	3	4	1		
Medium (clay)	9	7	6	6	6	4	3	
Low (sand)	13	11	10	8	8	7	6	5

The medium rainfall intensity of about 200 is most common in Kenya, as are the loam and clay soils. Judging from the figures of the table it can be said that slopes of about 6 % and steeper should have terraces.

There is some scientific support for a limit of about 5 %. According to research in Hungary there is a clear increase in soil loss through erosion on slopes steeper than 5 %.

The semi-arid areas with low rainfall and poor vegetation cover should, according to experience in Kenya, have the limit reduced to about a half of 6 %, i.e. all sloping land should be terraced. On the other hand, on slopes of heavy clay the percentage figure of 6 % might be doubled.

## WATERCOURSES

### Previous rules

According to the Agriculture Act cultivation is prohibited on the banks of watercourses within 6 feet (1.8 m) of the watercourse or, if the watercourse is wider than 6 feet, within a distance equal to the width of the watercourse, but not exceeding 100 feet (about 30 m).

The definition of a watercourse is not given in the Act, and landowners do not understand the rules. They put the following questions:

- a) Why should low banks without any strong water flow present, be protected against erosion? See Fig. 26 a on the next page.
- b) Why must flat land above the river not be cultivated?  
Fig. 26 b.
- c) and How can a river erode land above its highest water level?  
Fig. 26 c.

These objections give cause for the following amendments to the Act.

### Conclusions and amendments

In regard to slopes along watercourses, the soil conservation measures for slopes in general are valid. However, in the potential flood zone the ground must be protected, if the flow is liable to cause erosion. On such ground maize and vegetables must not be cultivated. Permanent grass and/or trees are recommended. Not only the normal high-water zone, but also the exceptional flood zone should be considered when estimating the height of the area to be protected from erosion.

#### How can you find out the height of the flood zone?

Ask the farmer to show you the very highest water level, and let him point out that level on the bank of the river.

The type of vegetation and evidence of previous erosion might help you to check whether the farmer's information is reasonable. The highest water level is the upper limit of potential erosion — called the erosion zone in the amendments. See Fig. 27, p. 132.

#### How can you know if the speed of water will be erosive?

You will have to ask the farmer if the current is fast during high water flows. If eddies occur in the water, the speed of the flow will probably be erosive.

CULTIVATION ALONG WATERCOURSES  
PREVIOUS RULES

Fig. 26

a. Watercourse less than 6 feet wide

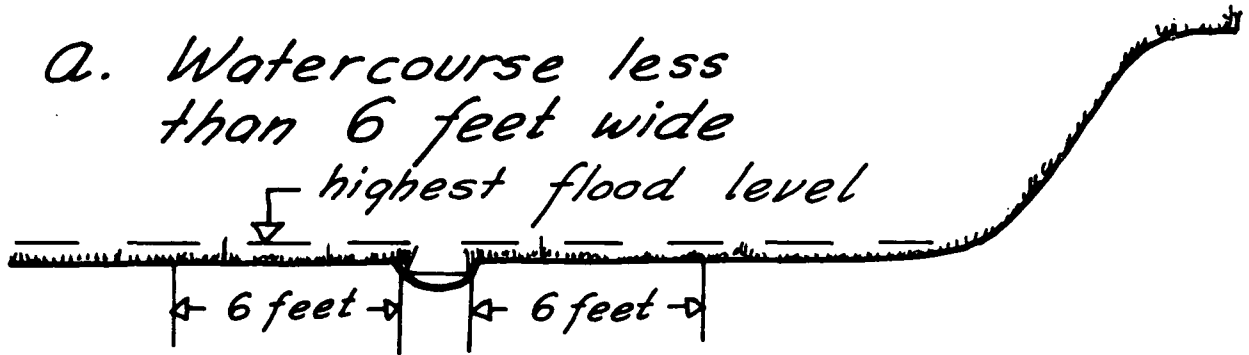

b. Watercourse more than 6 feet wide

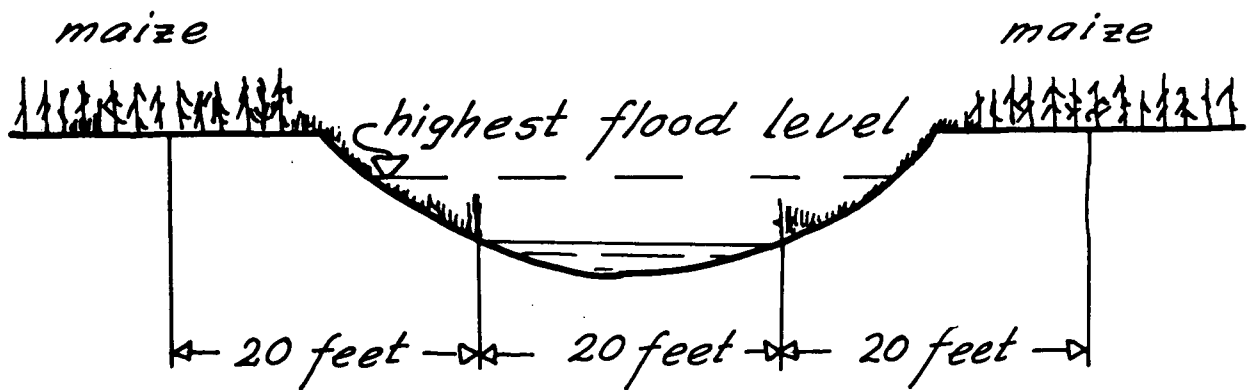

c. Watercourse more than 6 feet wide

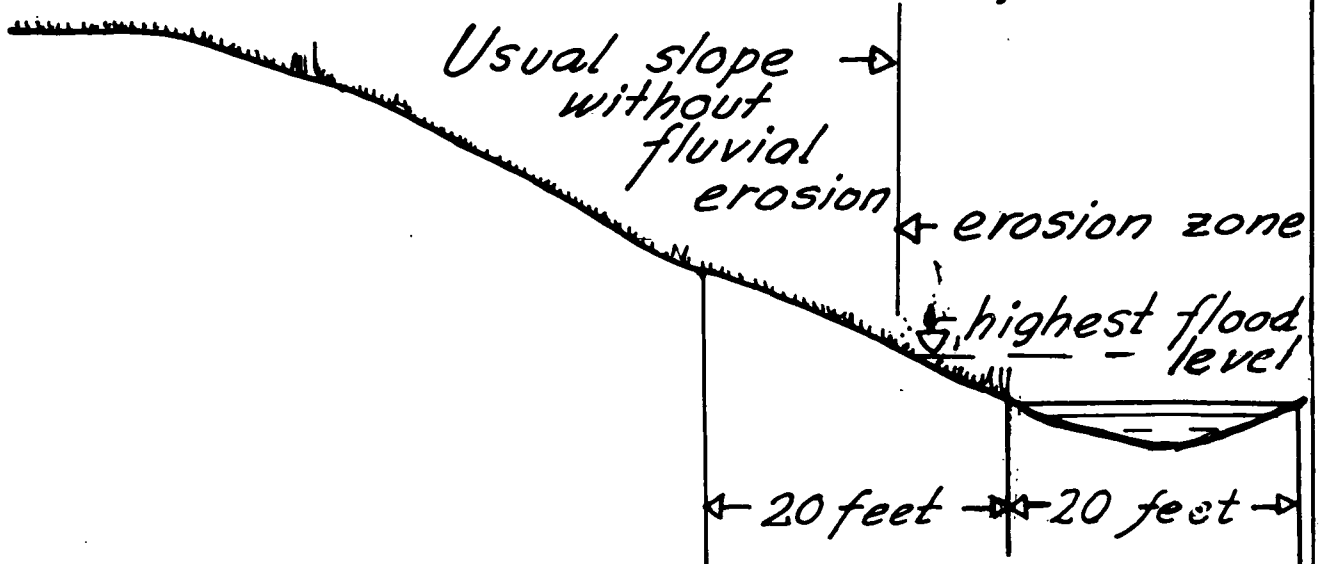

C. G. W.



CULTIVATION ALONG WATERCOURSES  
AMENDMENTS

Fig. 27

The flood zone (erosion zone) along rivers with a) steep, narrow banks b) low, wide banks

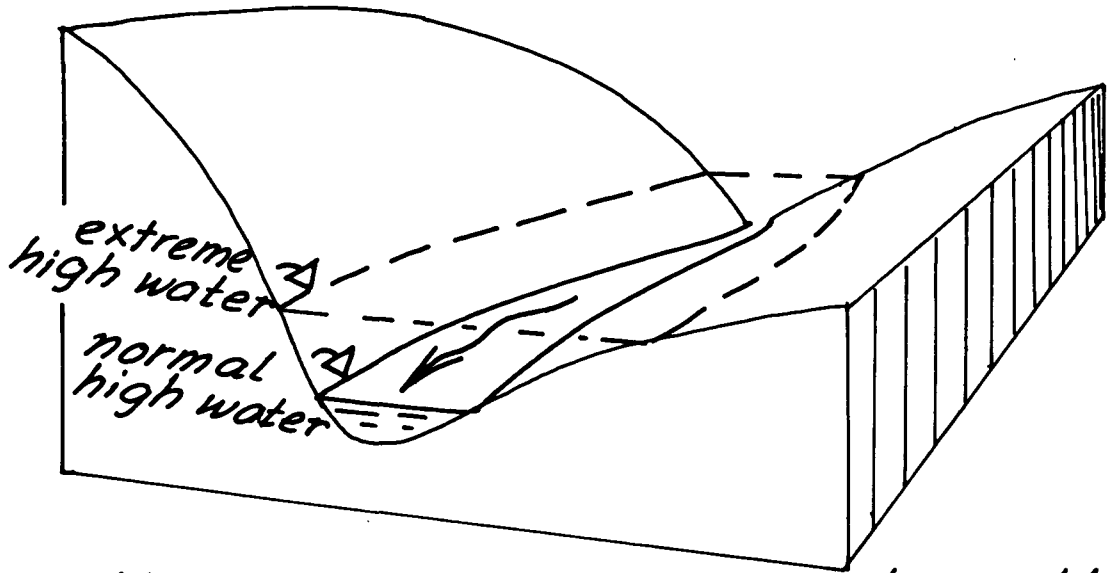

a. Narrow and deep valley where the flow is likely to be sufficient to cause erosion

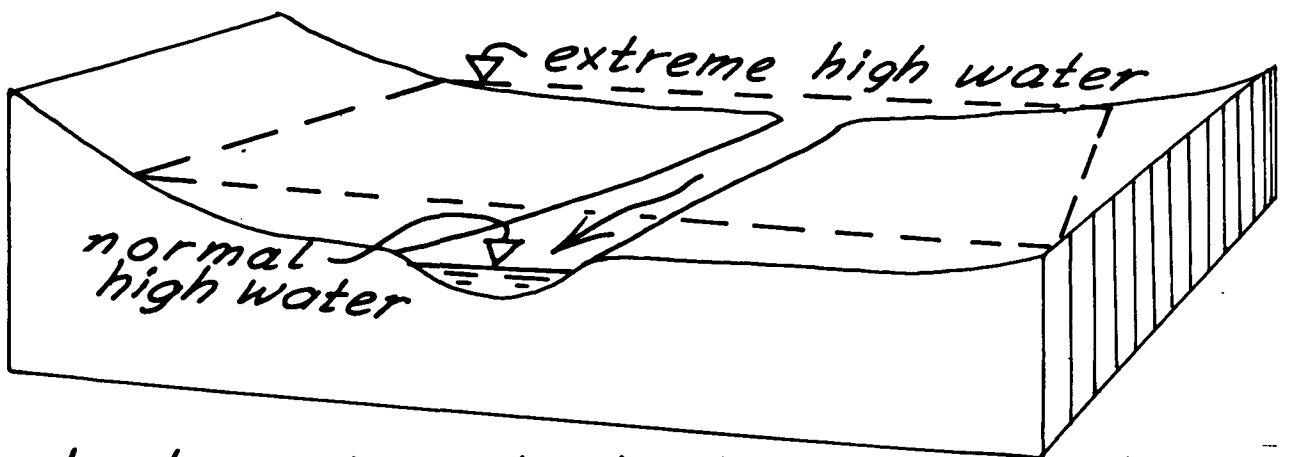

b. Low river banks in a wide valley where the ground of the flood zone does not need to be protected

### Bends of watercourses

Erosion does not usually occur on both banks of a watercourse. Most erosion occurs in the bends of a watercourse. In the steep bends of watercourses, where erosion has occurred or can be expected, natural vegetation or planted trees are better than grass by itself. The reason being that the roots of trees and bushes are good protection against erosion, reaching deeper into the ground than grass roots. The advantage of tall grass along river banks is that the grass slows down the speed of the water.

### Distances from watercourses

If flat land bordering watercourses, e.g. the Nyando Plains, is flooded, there will be risks of erosion on the flood plain, but only under specific conditions. A flat flooded plain has a water level similar to that of a lake. If strong flows of water should occur under specific and temporary conditions, the resultant erosion would not be related to the specific distance from the river bed. This type of wide flooded land should not be regarded as an erosion zone, as the water is not liable to flow fast, and consequently would not be capable of eroding flooded cultivated land.

### THE TEXT OF THE AGRICULTURE ACT

The text is printed on p. 134-136. The amendments, provisionally used in the Soil Conservation Project, are printed in larger letters than the original text.

When writing this, the upper limit for cultivation without terracing (12 %) has not been changed.

A national law for land use concerning soil conservation exists only in a few countries of the world. Soils, climate and crop patterns differ so much within a country, except very small ones, that a general law for soil conservation is not possible. If such a law is established, local regulations are needed, approved by competent and responsible authorities in Ministries or Provinces.

LEGAL NOTICE No. 26

(LAND/USE/LEG/1)

THE AGRICULTURE ACT

(Cap. 318)

IN EXERCISE of the powers conferred by section 48 (1) of the Agriculture Act, the Minister for Agriculture and Animal Husbandry, with the concurrence of the Central Agricultural Board, hereby makes the following Rules:—

THE AGRICULTURE (BASIC LAND USAGE) RULES, 1965

1. These Rules may be cited as the Agriculture (Basic Land Usage) Rules, 1965, and shall apply to all land in Kenya excepting plots of not more than two acres used for residential purposes only within a municipality, a former township, or township, and lands used for recreational purposes. Title.

2. In these Rules, unless the context otherwise requires— Definitions.  
"authorized officer" means the Director of Agriculture, a Regional Agricultural Officer, a District Agricultural Committee and any person appointed in writing in that behalf by the Director, a Regional Agricultural Officer or a District Agricultural Committee;  
"owner" means the occupier, cultivator or right holder of the land in question;

"percentage slope" means the vertical interval expressed as a percentage of the horizontal distance between two points;

"vegetation" means trees, ~~palms~~ bamboos, stumps, ~~brushwood~~, undergrowth, reeds and grass; *shrubs*

"watercourse" means a water flow in a channel or depression flowing either continuously or intermittently;

"erosion zone" means an area along a watercourse flooded by a water flow; not only should the height of normal annual high water be considered but also the height of extreme high water flow; secondly erosion can occur only if the flow of the flooded area is likely to be sufficient to cause erosion.

3. Any person who cultivates, cuts down or destroys any vegetation without planting trees, or depastures any livestock on any land of which the slope exceeds 55 per cent shall be guilty of an offence. Protection of land with slope exceeding 55 per cent.

Provided that an authorized officer may authorize an owner to cultivate, depasture, cut down and destroy vegetation on such land subject to such conditions as he may decide. An example of exception is pasture on slopes exceeding 55 per cent, if the soil is thick enough and if there is no risk of earth flow or landslide.

4. Any person who cultivates slopes exceeding 35 per cent without bench terraces or who cuts and destroys natural vegetation without replacing it with trees and/or permanent grass, shall be guilty of an offence.

Protection of land with slope exceeding 35 per cent. (but not 55)

Provided that an authorized officer may authorize an owner to cultivate, depasture, cut down or destroy vegetation on such land subject to such conditions as he may decide.

An example of an exception is cultivation of tea with proper cut-off drains or other measures.

5. (1) Any person who cultivates any land of which the slope exceeds 12 per cent and does not exceed 35 per cent unless the soil is protected against erosion by conservation works to the satisfaction of an authorized officer shall be guilty of an offence.

Protection of land with slope exceeding 12 per cent.

but not 35

(2) Where the soil on any slope exceeding 12 per cent is not, in the opinion of an authorized officer, adequately protected against erosion, he may, by written order, require the owner to construct such works or to carry out such repairs as he deems necessary within such reasonable period of time as may be specified in such order.

(3) Any person, who cultivates by ploughing or other means any land of which the slope exceeds 12 per cent except along the contour, or, except with the written permission of an authorized officer, digs or ploughs any boundary furrows, trenches or ditches on such land, shall be guilty of an offence.

Protection of watercourse.

6. Any person who, except with the written permission of an authorized officer, cultivates

the erosion zone with anything else than grass and/or trees or other plants totally covering the ground, or who does not replace cut-down or in other way destroyed natural vegetation with grass and/or trees, shall be guilty of an offence.

Protection against erosion by run-off water.

7. (1) Any person who uses any channel, ditch, or drainage way which has been constructed for the removal of run-off water as a footpath, road, wagon track, or livestock track shall be guilty of an offence, and the owners of the land over which such channel, ditch or drainage way passes, and of the adjoining land, shall comply with any orders issued by an authorized officer for the effective removal of run-off water and the avoidance of erosion.

(2) The owner of any land shall take such steps as an authorized officer may determine to prevent water from flowing on to any adjoining land in such manner as to cause the erosion thereof, and shall comply with such orders as may be given by an authorized officer to carry out such measures as the Authority deems necessary to prevent such erosion.

(3) Anybody who disposes any run-off, e.g. from construction works, culverts, road ditches or any other drains, without the advice or consent of an authorized officer and because of that causing a water flow eroding land, shall be guilty an offence.

Offences.

8. Any person who fails to comply with any order or with any conditions made under these Rules shall be guilty of an offence.

Appeal.

9. Any person aggrieved by a decision taken, or any order made, under these Rules may, within 28 days of such decision or order, appeal to the Agricultural Appeals Tribunal, whose decision shall be final and shall not be questioned in any court.

Penalty.

10. Any person who is guilty of an offence under these Rules shall be liable to a fine not exceeding five thousand shillings or to imprisonment for a term not exceeding six months or to both such fine and imprisonment.

District Agricultural Committee may make Regulations.

11. A District Agricultural Committee may make regulations relating to agriculture and land usage under these Rules in respect of the district for which it is established.

Table  
for converting degree of slope into  
percentage slope and vice versa

Fig. 28

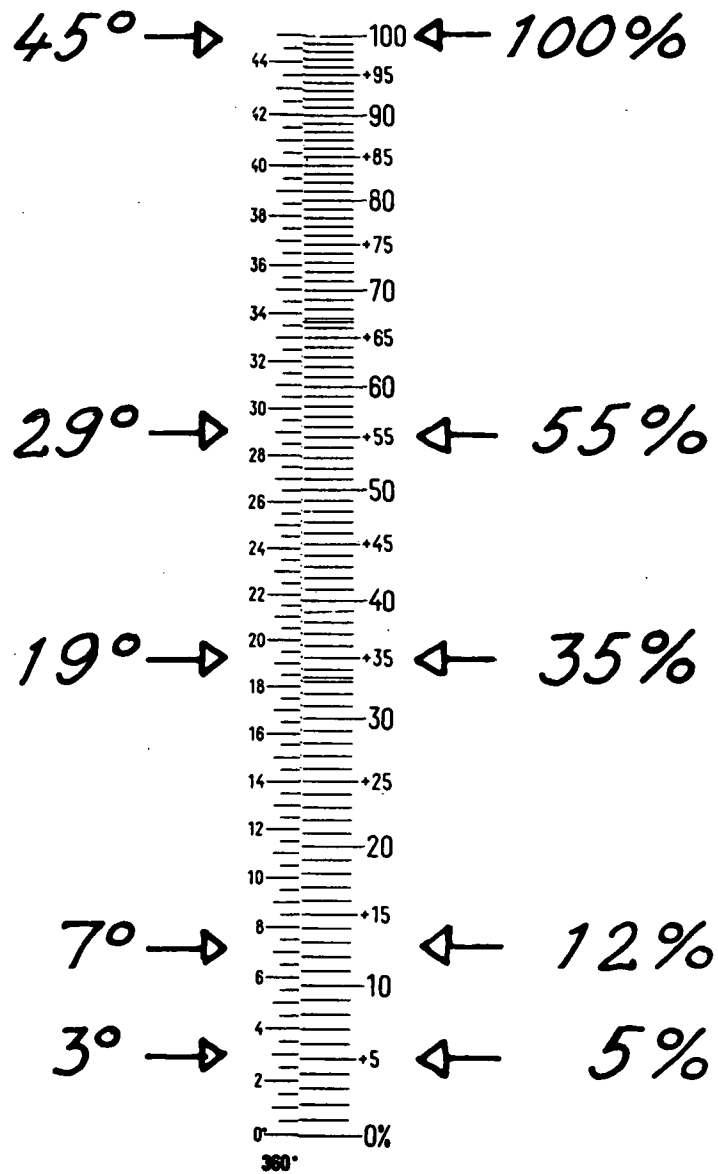

VII SOIL CONSERVATION IN FARM PLANNING

C O N T E N T S

	pages
1. Introduction	138
2. Classification of land based on slope and soil	138 - 140
3. Estimated rainfall	140 - 141
4. Cultivation on steep and very steep slopes	140 - 142
5. Cultivation of potential flood areas along watercourses	142 - 143
6. Usage of terrace edges and cutoff embankments	143
7. Pastures	143 - 144
8. The question of burning vegetation	145

## INTRODUCTION

Farm planning means planning and dividing a farm into homestead and fields so as to obtain the best use from the land; and it embraces arable areas, pastures, tree plantations, homestead, roads, water supply, drainage and physical soil conservation measures. In most cases of farm planning, however, the farm is being cultivated already, so the changes to be carried out tend to be rather limited.

As can be seen from the paragraph above soil conservation is a part of farm planning, and in this respect farm planning has to consider;

1. Areas available for cultivation, livestock and trees
2. Ground conditions as to the type of soil, occurrence of rock outcrops, infiltration rate, and erodibility
3. Present erosion on slopes and along watercourses, and existence of gullies and damaging sedimentation
4. Existing soil conservation measures, including the usage of different areas considering the soil conservation
5. New proposals for soil conservation measures, including the usage of different areas under the proposed soil conservation measures
6. The need for loans.

In this chapter notes are given on the following items:

1. Classification of areas based on slope and soil
2. Estimated precipitation
3. How to use steep and very steep slopes
4. How to use potential flood areas along watercourses
5. Usage of terrace edges and cutoff embankments
6. Pastures
7. The question of burning vegetation

## CLASSIFICATION OF LAND BASED ON SLOPE AND SOIL

If the topography is hilly, field boundaries should coincide with the contours, or the gradients of cutoff drains and terraces. This should of course also be valid for the boundaries between farms, to be considered during the land adjudication work.

The following terminology as to percentage of slope is used by the Soil Survey of Kenya:

flat/almost flat	less than 2 %
gently sloping	2 - 6 %
sloping	6 - 8 %
strongly sloping	8 - 13 %
moderately steep	13 - 25 %
steep	25 - 55 %
very steep	more than 55 %

In field work the soil can be determined as clay, loamy, silty or sandy:

Detailed classification	Field determination	Erodibility	Infiltration rate
clay clay loam	} clay	light gully and river erosion. medium splash erosion	insignificant except for dry cracks
loam			
silt clay silt loam	} silty	heavy splash erosion and solifluction heavy gully erosion	rather low rather high
sandy loam			
sand	} sandy	heavy river erosion	high

As to "effective" soil depth the following terminology is used by the Soil Survey of Kenya:

rock	less than 0.1 m
very shallow	0.1 - 0.25 m
shallow	0.25 - 0.5 m
moderately deep	0.5 - 0.8 m
deep	0.8 - 1.2 m
very deep	more than 1.2 m

Now we can classify land in regard to its soil conservation needs:

1. Flat land, sloping less than 2 %, can usually be farmed without any special soil conservation measures.
2. Gently sloping land from 2 to 12 %, where physical soil conservation measures are not obligatory according to the Agriculture Act, but desirable on slopes of erodible soils and in semi-arid areas.
3. For slopes exceeding 12 %, but not exceeding 55 %, terracing is needed. Bench terraces can be used, if the depth of the soil is more than 0.5-0.8 m. On steep slopes, especially if exceeding 35 %, modified bench terraces can be recommended. Tractors working along the contour can be used up to 17 %.



4. Slopes exceeding 55 % should be covered by grass and/or forest. There are other alternatives (p. 140 and 142).
5. Soils, which are rocky, stony or shallow, should be used as pastures or for forest.

### ESTIMATED RAINFALL

The national annual precipitation can be seen from the map on the next page (Fig. 29). With the aid of this map the annual precipitation for a particular farm can be estimated. This information is needed for proposals on cultivation, e.g. types of crops, grass species and fruit trees.

### CULTIVATION ON STEEP AND VERY STEEP SLOPES

On steep slopes (25 - 55 %) it is convenient to cultivate coffee on terraces (6 or 3 m wide), or fruit trees and bananas on modified bench terraces.

Avoid planting tobacco on steep slopes. Keep the rotational periods of tobacco short between the periods of grass. The reason for this can be seen in the table below, where there are figures for a comparison with maize:

	Soil losses in tons/acre	
	1st year	2nd year
On a medium slope		
maize	1.8	4.5
tobacco	3.6	10.9
On a steep slope		
maize	2.5	10.5
tobacco	12.3	48.0

On very steep slopes (exceeding 55 %) there are two main alternatives (Nos. 1 and 2 below) and five other alternatives for special cases (Nos. 3 - 7 p. 142).

1. Grass as a high yielding fodder crop, e.g. napier grass and bana grass, or local grasses as a pasture. The benefits of grass are:

- a) protection of soil from raindrop erosion
- b) high infiltration rate along roots, and through previous root holes.
- c) filtering water into non erodible flows
- d) depositing transported sediment.

To be effective the grass cover must be dense, without bare spots and without paths, where people and cattle have compacted the soil through trampling.

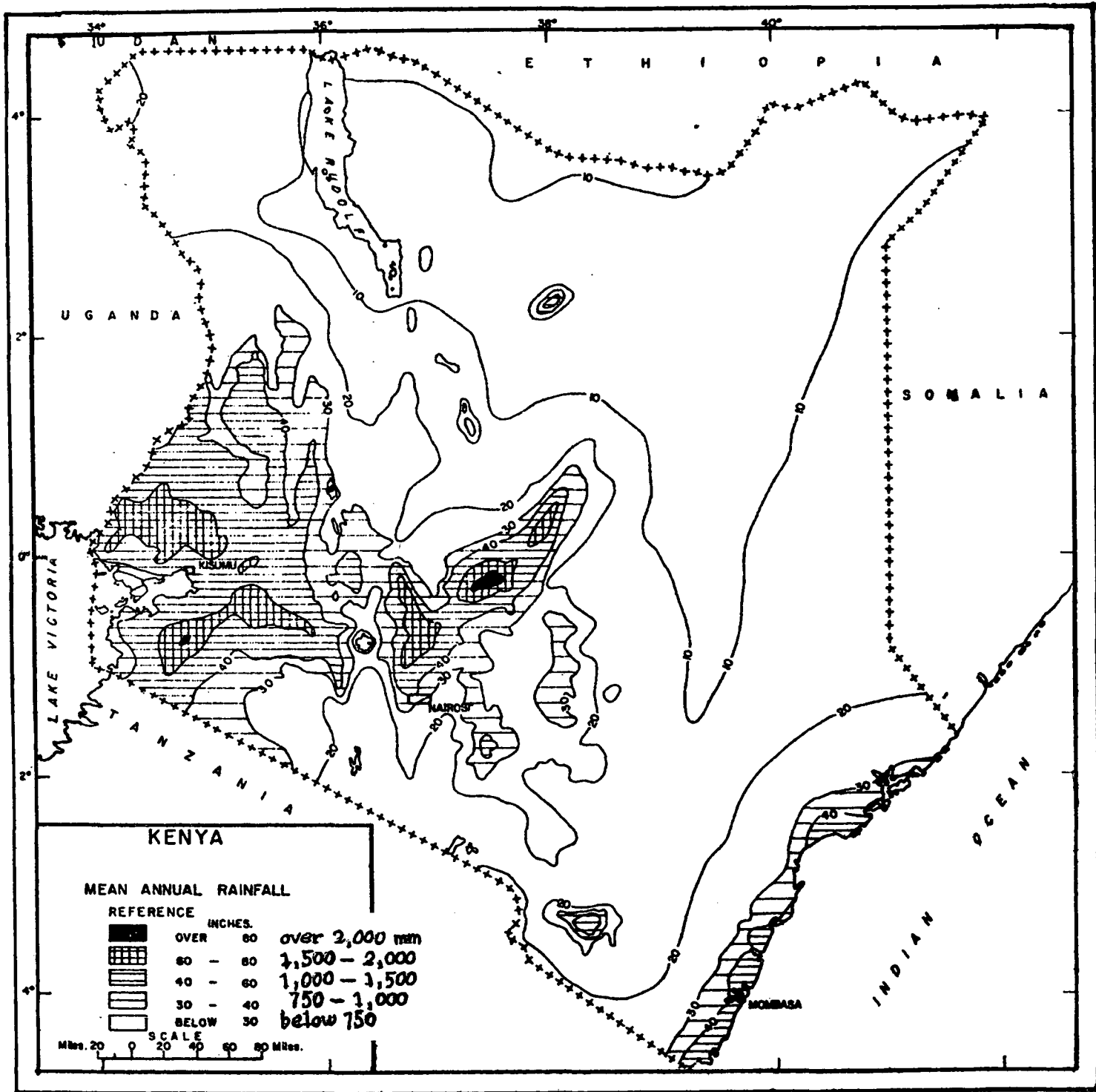

Fig. 29. Mean annual rainfall

(from the National Report on the Human Environment in Kenya)

Root splits, which establish themselves faster, or stem cuttings (with at least 2 nodes) can be planted 2 feet apart in the row and up to 5 feet apart between rows.

2. Timber trees should preferably be planted on the steepest slopes, if the farmer wants a tree plantation. On more gentle slopes a good grass cover may be more efficient than trees in conserving the soil.

For fuel purposes (especially for curing tobacco) Eucalyptus can be considered. Eucalyptus grows well in all areas and is suitable for overgrazed areas with little soil left. Calculate the requirements and ask a forest officer for advice.

From a soil conservation point of view cypresses and pines for timber are more suitable on steep slopes than fast growing fuel species. Even the slow growing indigenous trees such as podo, cedar, olive or mueri can be used, if one is more interested in protecting the soil than having a quick economic return (Graham 1942).

3. Fruit trees are recommended for planting on modified bench terraces or individual modified bench terraces. See p. 128 and 120.
4. Tea, when well established, gives a very good protection against erosion.
5. Bananas can grow well on slopes without terraces, if a thick and continuous layer of trash is left all over the slope under the banana plants.
6. Sugar cane can be permitted, if its trash is left on the slope.
7. Stone terraces can be used for any crop or tree crop even on very steep slopes.

Often small slopes, steeper than the rest of the shamba, occur on a farm. Such areas should be used for permanent vegetation.

#### CULTIVATION OF POTENTIAL FLOOD AREAS ALONG WATERCOURSES

Along watercourses the natural vegetation of weeds, grass, bushes and trees should be left untouched up to the highest potential flood level point.

Alternatively the flood zone (erosion zone) can be used for grass, with or without trees or bananas. Densely growing wattle and

gum trees are not suitable, as these trees can prevent the establishment of any vegetative protective ground cover. Sugar cane may be permitted, but not maize and vegetables. These rules are valid only for those parts of the erosion zone, where erosion is liable to occur (p. 11, 130, 133 ).

If the river is used as a water supply and has a low discharge rate during the dry season, the planting of many trees along the river should be avoided, especially Eucalyptus and similar trees. In dry areas such trees 12 m high can each transpire 360 l/day.

#### USAGE OF TERRACE EDGES AND CUTOFF EMBANKMENTS

Grass growing along terrace edges can provide cattle with green fodder all the year round.

Trees should be planted along terrace edges (on the upper part of the grass strip) and on the embankments of cutoff drains. However, all tree species are not suitable (see p. 121 ).

Fruit trees can usually be seen scattered about the shamba, but they should be planted in rows along terrace edges. It is a profitable business to plant fruit trees. In the Kandani location of Murang'a District one acre without terracing gave only 5 bags of maize, worth  $5 \times 60 = \text{Shs } 300$ . But one single orange tree could give 10 bags of oranges per year, worth  $10 \times 40 = \text{Shs } 400$   
(1975 prices).

#### PASTURES

Land that should be put in permanent pasture is:

- 1) land that has not been broken by hoe or plough, and
- 2) land that has been misused in cultivation and is no longer suitable for crop production.

The first year the grazing should be light or none.

The grazing of a few well-fed cattle gives a better profit in the long run than overstocking.

In some districts a farm consists of cultivated land with terraces on the upper part, and pasture on the lower part of the farm. Such pasture is usually overgrazed with resultant sheet and gully erosion damaging the land. See p. 113. Reseeding and if possible fertilizing are needed. Fertilizing is also good for weed control.

No soil conservation measures should be taken without grazing control, if necessary destocking. Try to have the number of goats reduced.

They eat the shoots of young trees and bushes, so preventing regeneration of useful bushes and trees. Their close bite reaches down to the roots of the grass, which then will dry up, and die during the next drought. Flocks of goats make tracks through bush and grass, causing erosion on slopes. No good farmer can permit such desert makers to wander around his farm, particularly in the large numbers which are so commonly seen.

The stock carrying capacity expressed as stock units (see p. 151) is shown in the table below (figures mainly from Pratt 1968):

Ecozone No.	No potential	High potential		Medium potential		Low potential
	I	II	III	IV	V	VI
Area in sq.km	800	53,000	53,000	53,000	300,000	112,000
Climate type	Alpine	Humid	Transi- tional	Semi- arid	Arid	Very arid
Annual rainfall in mm		>1600	1600-800	800-500	<500	<300
No.of seasons when less than 300 mm				4 in 8	5 in 8	6 in 8
Natural vegetation	Grass, moor, barren	Forest	Green bush- land, savannah	Savannah + acacia	Thorn- bush- land	Thorn- scrub, barren
Agricultural characteri- stics	Above forest lime	Tea, pyreth- rum, dairy	Coffee, dairy	Sisal,cotton, pulses, sun- flower, ranching	Scattered cultivation	Range land
Food crops			Maize, wheat, barley	Maize on bench terraces	Sorghum Millet	No crops
Characteristic grasses	Alpine grasses	Kikuyu grass	Star- grass	Rhodes grass, makarikari	grass	Annual grass
Ha required per stock unit (= 450 kg)		0.8	1.6	4	6-12	15-40
Acres required per stock unit		2.0	4.0	10	15-30	40-100
Livestock units to support one human		2.5	3.0	3.5	4	4.5
Max. population density, humans per sq.km		50	21	7	2	<1

Webster, C. C. and Wilson, P. N.: Agriculture in the tropics. - Spottiswoode, Ballantyre and Co Ltd, London and Colchester 1966.

This excellent textbook has a short but good chapter on soil conservation.

Verbugt, W.H.: Pasture handbook, Kenya Seed Company Ltd, January 1979.

VIAK EA LTD : Migori-Kihancha regional master plan. Water and land utilisation, Nairobi 1975.

Wischmeier, W.H.: Cropping-management factor evaluations for a universal soil-loss equation. - Soil Science Society of America, Proceedings Vol. 24, Madison 1960.

#### Addenda

Graham, R.M.: Tree planting on farms. - Forest Department, Republic of Kenya 1974.

Greenham, D.J. and Lal, R.: Soil conservation and management in the humid tropics, John Wiley & Sons, Chichester etc 1979.

## ALPHABETIC SUBJECT LIST

### A

Absorption terrace, 97  
Acacia albida 116, 121, Appendix 3 p 2  
Adjudication of land, 138  
Adjudication maps, 157  
Aerial photographs, 157  
African Foxtail, 111, Appendix 2 p 2  
Agriculture Act, 123, 134-135, 139  
Agro-forestry, 49, 114, 115  
Algaroba, 115, 116, Appendix 3 p 2  
Annual rainfalls, 141, 144  
Annual soil loss, 22  
Apple Ring Acacia,  
  see Acacia albida  
Apples, 122  
Approach to farmers, 147  
Arnoldus, 30  
Artificial waterway, 70, 191  
  cross-section, 70-73  
  design, 72  
  depth, 73  
  grass cover, 73-74  
  illustration, 51-51, 72  
  lock and step drain, 74  
  need, 70  
  siting, 70, 73  
  subsidies, 53  
  width, 71-73  
Avocados, 122  
Azadirachta, see Neem tree

### B

Badlands, 109  
Bahia Grass, 97, Appendix 2 p 5  
Bamburi, 116  
Bana Grass, 9, 40, 96  
Bananas, 45-46, 118-119, 121, 122,  
  127, 142  
Baringo District, 111  
Basin listing, 44  
Bauhinia, 121a  
Beckley, 74

Bench terrace, 4, 33, 48, 51,  
  75-77, 86-92, 93, 95  
Bermuda Grass, 97  
Biological measures, 36  
Blind terrace, 97  
Bogdan and Pratt, 110  
Botriochloa insculpta, Appendix 2 p  
Brachiaria decumbens, 97  
Broad - base terrace, 75-77  
Buffel Grass, 111, Appendix 2 p 2  
Buffer strip cropping, 46  
Buffer strips, 30a, 46  
Building poles, 122  
Burning, 110, 145  
Bush hedges, 49  
Bush rye, 111, Appendix 2 p 3

### C

Calcium, 39  
Callitris robusta, 19  
Cameroon, 121a  
Cassava, 30  
Cassia, 121, 121a, 122, Appendix 3 p 3  
Cashew nut, 121, 122  
Casuarina, 19, 121, 121a, 122  
Catchment area, 57  
Cedar, see Juniperus  
C- factor, 27-30a  
Cenchrus ciliaris, 111, Appendix 2 p 2  
Channel factor, 61  
Channel terrace, 30a, 75-77  
Charreau and Vidal, 121  
Check dams, 9-10a, Appendix 1  
Chloris gayana, 111, Appendix 2 p 2  
Christoi, 43  
Citrus, 116 121  
Clayton, 168,  
Classification of land 138, 193  
Climate, 144  
Climometer, 177, 183  
Clods, 38-38a  
Closing from grazing, 110

## C-Continued

- Coconuts, 121
- Coffee, 30, 140
- Cohesion of soil, 5, 25
- Colin Maher, 84
- Coleus barbatus, 49
- Coloured Guinea Grass, 111, Appendix 2 p 4
- Companion crops, 30b, 40, 43-44
- Conocarpus, 19, 121a 122
- Conservation terrace, 47
- Constant vertical interval, 84-88
- Contour belts, 45-45a
- Contour farming, 7, 30a, 43-44
- Contour ploughing, 43-44
- Contour strip cropping, 7, 18
- Converse terrace, 78
- Conversion tables  
degrees and percentages slope, 136  
metric system, Appendix 4
- Cook's method, 57
- Costs, 66, 99-104
- Cotton, 30
- Counter pressure, 16
- Cover crops, 30
- Creeping Bluegrass, Appendix 2 p7
- Creeping Signal Grass, 97
- Cropping factor, 27-30
- Crop, 30, 40  
choice of crop, 40  
companion crops, 30b, 40  
crop stage periods, 27  
early planting, 40  
rotation, 7, 42-43
- Crotolaria, 49
- Croton megalocarpus, 121a
- Crumb structure, 42
- Cultivation  
steep slopes, 170  
very steep slopes, 140, 142
- Cultural measures, 38
- Cupressus, 19, 121, 122
- Cusecs, 60
- Cushion Lovegrass, 111
- Custard Apple, 122
- Cutoff drain, 50-69  
calculation and design, 54-63a, 65  
costs, 66  
cross-section, 53-62, 65  
depth, 54, 62  
digging, 65, 68  
discharge, 53  
embankment, 54-55  
example, 63  
gradient, 64  
grass, 143  
grazing control, 112-113  
illustration, 51, 55  
grazing control, 64, 112-113  
illustration, 51  
layout, 174, 181  
length, 65  
maintenance, 66-69  
need, 52-53  
outlet point, 53  
questions, 63b, 69a  
survey of site, 52-53  
trees, 64  
vegetational cover, 64, 118-121  
width, 54-55, 62
- Cutting of forest, 12
- Cynodon dactylon, 111, Appendix 2 p 2

## D

- Dates, 122
- Depth of soil, 139
- Destocking, 110, 112
- Developed bench terrace, 48, 77,  
89, 92, 93
- Digging costs, 66, 99-104, 196
- District Development Committee, 106



## D - Continued

Diversion ditch, 9, 52, 69  
 bush/grassland, 52  
 cultivated land, 52  
 gully control, 9  
 illustration, 51  
 tea, 69  
 Dol Dol, 112  
 Durbach's method, 61

## E

Early planting, 40  
 Earth flow, 14  
 Ecozones, 144  
 Energy of raindrops, 4, 22, 24  
 Enteropogon machrostachyus, 111, Appendix  
 2 p 3  
 Eragrostis caespitosa, 111  
 cilianensis, 111, Appendix 2 p 3  
 superba, 111, Appendix 2 p 3  
 Erodibility, 5, 17, 25, 81  
 Eros Data Center, 160  
 Erosion, 36, 185  
 causes, 36  
 different crops, 40  
 geological, 36  
 grazing land, 109  
 gully erosion, 8  
 natural, 36  
 nutrients, 95  
 pavement natural, 3  
 artificial, 71  
 rain drop erosion, 3, 41  
 reduction, 38, 117  
 rill erosion, 6  
 river erosion, 11, 130-133  
 slope, 6, 124-129  
 soil loss, 21-21  
 solifluction, 14  
 splash erosion, 3  
 stream erosion, 5

watercourses, 130-133, 142, 150  
 velocity of water, 5, 13  
 wind, 17  
 wind erosion, 17

Erosion pavement, 3  
 Erosion zone, 130, 142, 150  
 Erosive rain, 4  
 Erosivity, 24  
 Eucalyptus 14, 118, 121-122, 142-143  
 Excavated bench terrace, 75-77,  
 88b, 89-90

## F

Fallow, 27, 109  
 Fanya Juu terrace, 75, 92-95, 98  
 Farm management, 38, 185  
 Farm planning, 137  
 Farmers, 147  
 Fertility, 39  
 Fertilizers, 39, 42  
 Ficus, 121a  
 Finger Euphorbia, 49  
 Flood zone, see Erosion zone  
 Flooding, 12  
 Fodder trees, 112, 115, 121, 122  
 Forest, 30, 30a  
 Formulas for intervals, 81, 87-88  
 Fournier, 38a  
 Fractions of soil, 5  
 Fruit trees, 122, 142

## G

Gabions, 13, Appendix 1 p 8-12  
 Gitau Nyoro, 92  
 Gmelina, 122  
 Goats, 144  
 Grade, see Gradient

## G - Continued

Gradient of cutoff drains, 64  
terraces, 97-98

Graham, 142

Grass  
cover, 30-30a, 95-98, 113, 140  
reseeding, 110  
perennial, 109-110  
seed rate, 111  
species, 96-97, 111, Appendix 2  
strips, 30a, 47-48, 95

Gravel, 25

Grazing control, 110, 113

Grazing land, 108, 143

Green manuring, 42

Grevillea, 19, 121

Grey Lovegrass, 111, Appendix 2 p 3

Groundnuts, 30

Ground water, 14-16

Guatemala Grass, 96

Guava, 121-122

Guinea Grass, 97, 111

Guiscafre, 121a

Gully control, 9-10a, 113, Appendix 1

Gully erosion, 8, 109

Gum tree, see Eucalyptus

H

Hall, 71

Handlevel, see Clinometer

Harrowing, 110

Hawaii, 4

H.I., see Horizontal interval

High - water zone, 130

Hillside ditch, 78, 92a, 94

Holtan, 41

Hook Grass, 111, Appendix 2 p 4

Horizontal interval, 81-81b, 83-87

Hudson, 39, 60

Human influence, 21

Humus, 121

Hydrological conditions, 12

Hypparhenia rufa, Appendix 2 p 4

## I

Idle land, 30

Infiltration, 6, 25, 41, 46, 57, 95, 109

Instructions to assistants, 146

Instruments, 161

Intensity of rain, 4, 22-24

International Development  
Research Centre, 115

Iron oxide, 25

Ironwood, 122

Ivory Coast, 95

## J

Jacaranda, 121a

Juniperus, 122, 142

## K

Kandani, 143

Kanga, 116

Kangema, 16

Kericho District, 69

Key terrace, 78

K-factor, 25

Kikuyu Grass, 73, Appendix 2 p 5

Kirinyaga District, 69

Kitui District, 92, 111

Kikuyu Grass, 73, Appendix 2 p 5

Kowal, 44

## L

Laikipia District, 112

Lal, 38a

Land slide, 15-16

Latipes senegalensis, 111, Appendix,  
Lay out, 167, 174, 193 2 p 4

Legislation, 123

Legume, 46

Length - Slope factor, 25-26a

Leucaena, see Lucena

Subject list L - O

L - Continued

Level terrace, 97  
Limes, 122  
Line level, 162, 183  
Listing, 44  
Literature, 184  
Livestock unit, 112, 144, 151  
Lock and step drain, 74  
Local characteristics, 57  
Loquats, 122  
LS - factor, 25-26a  
Lucena, 116, 121-122, Appendix 3 p 2

M

Macadamia, 116, 122  
Machakos District, 92, 111, 115  
Maintenance form, 66-69  
Maize, 30, 140  
Makarikari Grass, 97, 111  
Malawi, 54, 71  
Mangoes, 116, 121-122  
Mangum terrace, 76  
Manure, 42  
Maps, 153  
Marikari Grass, 92, 97  
Masai Lovegrass, 111, Appendix 2 p 3  
Mass movement, 15  
Matuga, 42  
Maximum terrace width, 84, 87  
Maximum velocity, 5, 61  
Maya-Indians, 116  
Mean annual rainfall, 141  
Measuring tape, 169  
Mechanized soil conservation, 101, 199  
Microclimate, 121  
Millet, 30  
Minimum tillage, 38a  
Modified bench terrace, 75-76, 87  
91-92, 119-120  
Moore, 95

Motor Grader, 101-104, 198  
Mueri, 142  
Mulberry, 122  
Mulching, 4, 30a, 41-42, 69  
Murang'a District, 143  
Murrum, 25  
Natural vegetation, 144, 150

N

NASA, 160  
Nandi Flame Tree, 121a  
Nandi Setaria, 97  
Napier Grass, 9, 96, 142, Appendix 2 p 6  
Narok District, 47  
Narrow - base terrace, 75-77  
Natural vegetation, 144, 150  
Neem tree, 121, 121a, 122,  
Appendix 3 p 3  
Negative geotropism, 14  
Ngelani, 115  
Nichols terrace, 76  
Nigeria, 38a, 44  
Nitrogen fixing, 118  
Nutrient pump, 121  
Nyeri District, 92

O

Oats, 69  
Olive, 142  
Oranges, 122, 142  
Organic matter, 39  
Overgrazing, 109, 113  
Overstocking, 109

Subject list P - S

P

P - factor, 30b  
Palms, 30  
Panicum, 97, 111, Appendix 2 p 5  
    coloratum, 97,111,Appendix 2 p 4  
    maximum, 97, 111, Appendix 2 p 5  
Papaya,122  
Paspalum notatum, 97, Appendix 2 p 5  
Pasture, 30, 41, 43, 112, 143  
Pasture furrow, 110  
Peaches, 115, 121-122  
Pears, 122  
Pennisetum clandestinum,73,Appendix 2 p 5  
    purpureum, 96, Appendix 2 p 6  
Peppar Tree, 19, 121a 122  
Pereira, 118  
Perennial crop, 46  
Physical measures, 36  
Piece work payment, 99-100  
Pineapples, 46  
Pinus patula, 121  
Pitting, 44  
Ploughing  
    along contour, 30, 43  
    up and down, 30  
Plums, 122  
Podocarpus, 122, 142  
Policy, 105-107, 198  
Pomegranate, 122  
Potatoes, 44  
Potential zones, 144  
Poulsen, 115  
Practice factor, 30a  
Pratt, 144  
Previous rules, 124, 130  
Profile levelling, 176  
Prosopis,116,121-122, Appendix 3 p 3  
Protein content, 115

Q

Quickset level, 169, 183

R

R - factor, 22 - 24  
Rain, 24  
Rain gauge, 22,  
Raindrop erosion, 3-4  
Rainfall erosion index, 27  
Rainfall factor, 22-24  
Rainfall map, 141  
Rangeland, 30  
Reafforestation,12,117,118  
Red Oat Grass,111, Appendix 2 p 6  
Register index map, 157  
Rehabilitation of grazing land,110  
Remote sensing, 160  
Retension terrace, 97  
Rhodes Grass, 97, 111, Appendix p 2  
Ridge terrace, 75-77  
Ridging, 30a, 43-44  
Rill erosion, 6  
Riser, 95-98  
River bank, 11-13, 118, 150, 196  
River control, 11-13, 118, 150,  
    Appendix 1  
River erosion, 11, 130-133, 150  
Rotation, 42-43  
Runoff, 12, 57

S

Satellite map, 160  
Savannah, 30  
Schinus molle, see Pepper Tree  
Scratch ploughing, 110  
Semi-arid area, 121-121a  
Senegal, 38-38a, 121

Subject list S

S-Continued

- Setaria, 97, Appendix 2 p 6
- She-Oak, 122
- Shear strength, 3,15
- Sheet erosion, 6
- Shelter belt, 18-19, 121a
- Sisal hedges, 46, 49
- Siting of cutoff drains, 52-53, 56  
terraces, 78-80
- Slides, 15-16
- Slip surface, 15
- Slumping, 15
- Slope %, 6, 75, 84, 124-129, 136, 164, 173, 179  
classification, 139  
length, 6, 25  
small slopes, 142  
without terracing, 129
- Soil  
aggregates, 39  
characteristics, 139  
classification, 5, 139  
clods, 38  
depth, 139  
divalent ions, 39  
erodibility, 5, 17, 25, 81  
erosivity, 24  
fertility, 39  
fractions, 5  
properties, 38  
sealing, 37
- Soil conservation, 36  
agreements, 149, 152  
alternatives, 147  
benefits, 199  
biological measures, 37  
buffer strip, 46  
check dam, 7-10a  
contour farming, 7  
crumb structure, 42  
cultural measures, 37  
farmer, 147  
force, 149  
grass strips, 47-48  
grazing land, 109-113  
gully control, 8-10a, Appendix 1  
layout, 167, 174  
machines, 75  
mechanized, 75, 101-104, 199  
mulching, 4, 30a, 41-42, 69  
physical measures, 37, 50  
planning, 147  
policy, 105-107  
reasons, 147  
rehabilitation of eroded land, 117-118  
rill erosion, 7  
river control, 11-13  
semi-arid area, 121-121a  
shelter belt, 18-19  
slopes, 124-129  
splash erosion, 4  
stone terrace, 95-96, 142  
strip cropping  
water, 7, 30a, 45-45a  
wind, 18  
stubble mulch tillage, 17  
trees, 150  
very steep slopes, 140  
water courses, 130-133, 150
- Soil erodibility factor, 25
- Soil loss, 21-22, 28
- Soil loss equation, 21  
examples, 31-34  
factors, 21-30  
questions, 34
- Soil loss ratio, 27
- Solifluction, 14
- Sorghum, 30
- South Nyanza, 112
- Spacing of cutoff drains, 52-53  
terraces, 81  
trees, 117

IX MAPS IN SOIL CONSERVATION

C O N T E N T S

	pages
1. Topographical maps	154 - 156
2. Register index maps	157
3. Aerial photographs	
used as maps	157 , 159
used with a stereoscope	158 - 159
4. Satellite maps	160
5. Practicals	160a - 160b

## TOPOGRAPHICAL MAPS

### Scale 1:250,000

This topographical map shows different altitudes above sea level in a series of 11 colours from light yellow to dark brown. Rivers and lakes are in blue, all-weather roads in red. There are contour lines at intervals of 200 feet.

Because of the scale (1 mm on the map = 250,000 mm on the ground = 250 m) this map is mainly used as a key map for an idea of the topography in broad outline, and for routes by car.

The sheets cover the whole of Kenya. See the diagram on p. 155 indicating names and Nos. of the sheets.

Price per sheet for delivery by the Survey of Kenya to the Ministry of Agriculture is shs 12.50.

### Scale 1:50,000

This map shows contour lines for every 50 or 100 feet, and some new ones at every 20 m. The rivers with their tributaries in blue are rather detailed, but many of the rivers flow only during short periods of the year. Boundaries of forests are in green. Some sheets have the Location and Sub-location boundaries printed in thick violet lines.

The scale is so big (1 mm on the map = 50,000 mm on the ground = 50 m) that the map can be used for regional planning of soil/water conservation. Catchment areas of rivers, or parts of them, can be identified. A percentage slope can be calculated from the map, using the distance between contour lines on the map and the interval between the contour lines.

#### Example:

Distance between 2 contour lines = 2 mm on the map = 100 m on the ground.

Vertical interval between 2 contour lines = 20 m on the ground according to the legend of the map.

Thus the percentage slope is a drop of 20 m in a length of 100 m = 20 %. Therefore all land, where the distance between the contour lines is less than 2 mm, is steeper than 20 %.

The sheets cover southwestern Kenya, i.e. the Highlands and from there a strip of land down to the coast. See the diagram on p. 156 indicating the sheets and their Nos. For the remainder of Kenya there are topographical maps to a scale of 1:100,000. The Government price per sheet is shs 12.50.

1:250,000 TOPOGRAPHICAL MAPS (Y503)

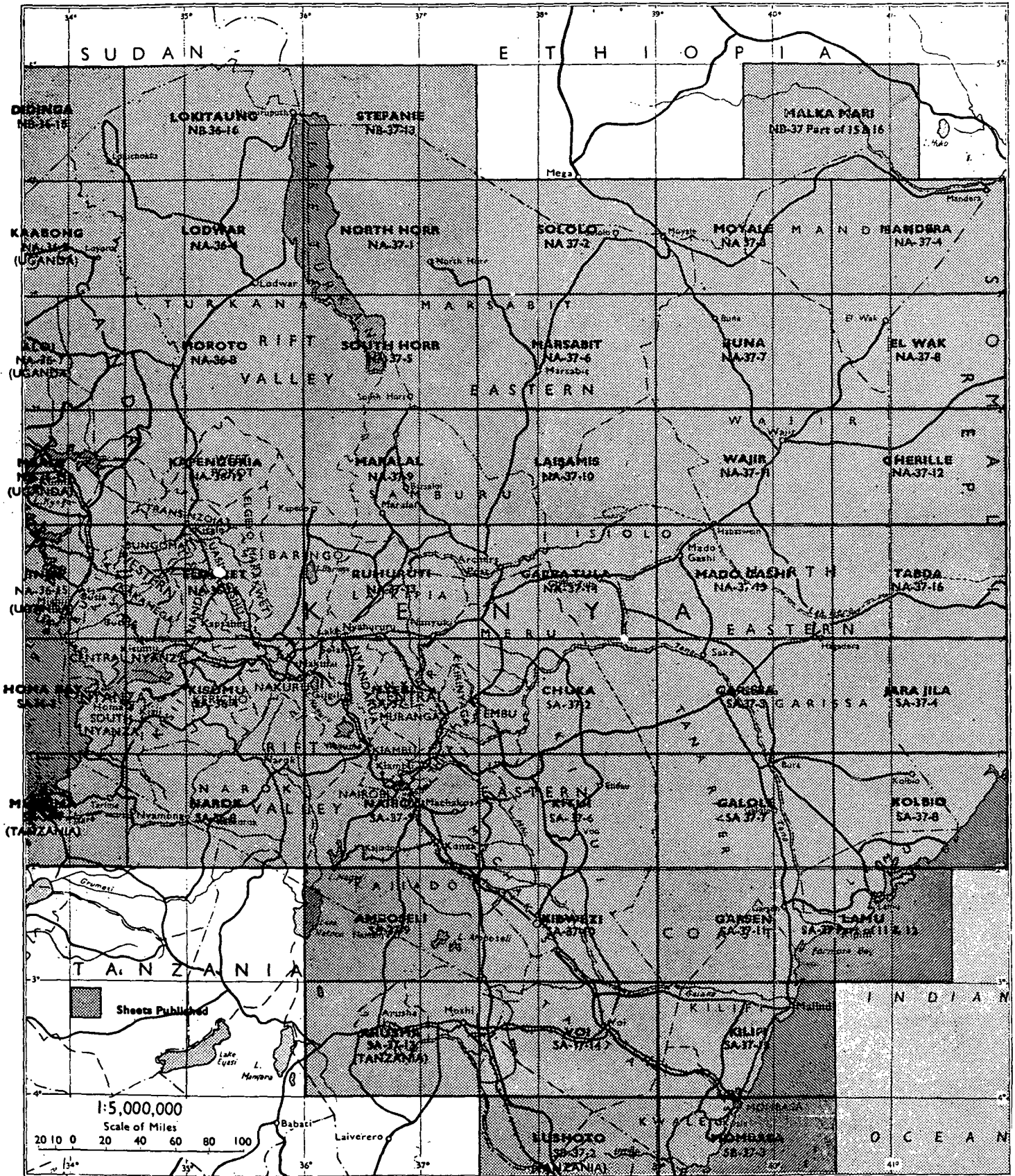



1:50,000 TOPOGRAPHICAL MAPS Y731

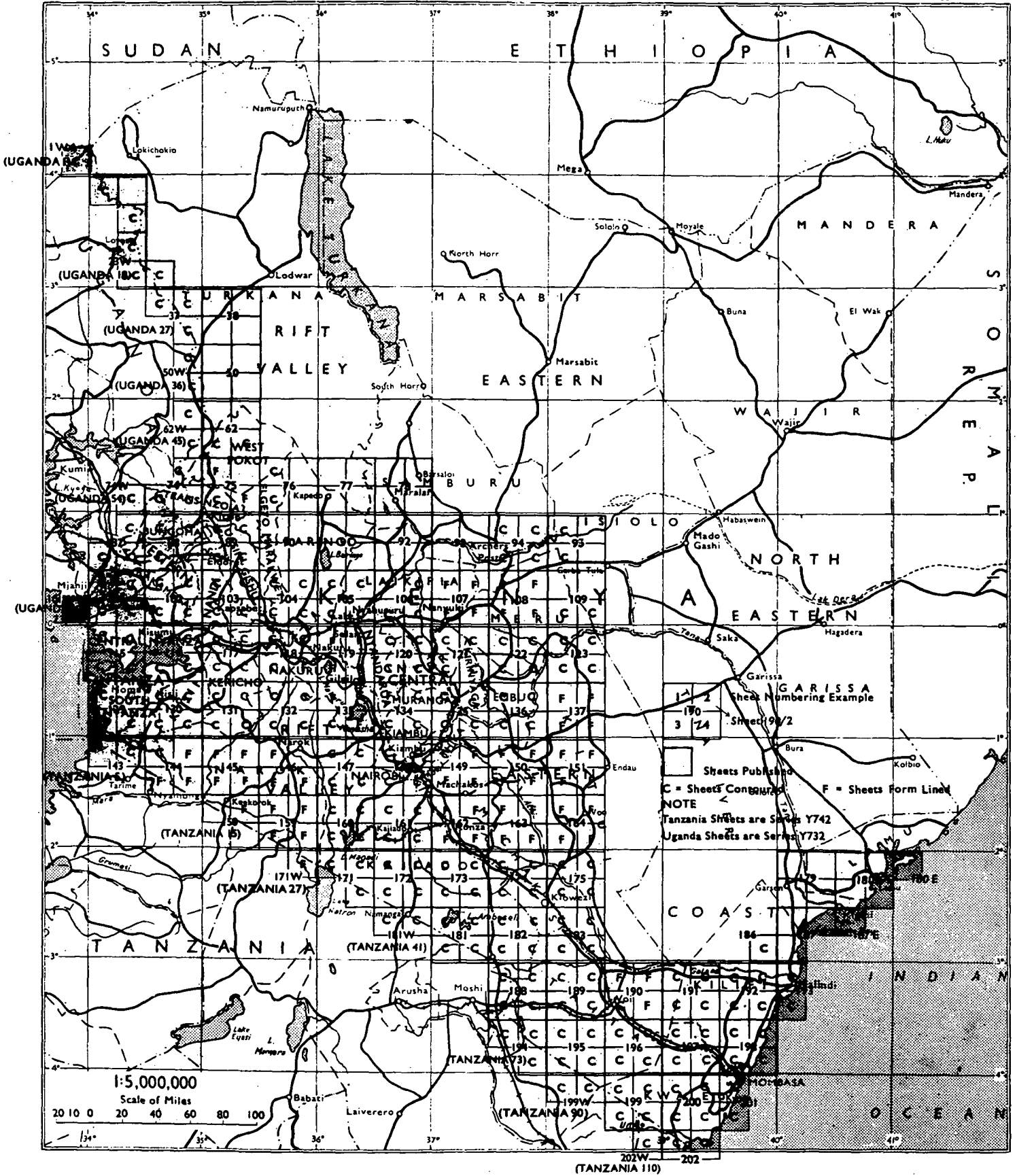

## REGISTER INDEX MAPS

### Scale 1:2,500

For the adjudication of land the Survey of Kenya produces maps showing boundaries of farms, roads and watercourses.

The price of dye-prints from the Survey of Kenya is shs 9.50 per sheet.

## AERIAL PHOTOGRAPHS

### Aerial photographs used as maps

Aerial photographs exist in scales of 1:80,000, 1:50,000, 1:25,000 and 1:12,500. The latter scale is so large that individual farms can be identified, houses and trees counted, terracing and gullies visible, etc. The scales mentioned can be enlarged up to 5 times, if the sharpness of the original photograph is good. Some of the oldest photographs are not so good.

Aerial photos have been taken as follows:	Years	Scale
Northern, northeastern and eastern Kenya	1956-60	1:80,000
The Coastland (approximately east of 38°30'E)	1961-62	1:50,000
	1969-70	1:50,000
Main part of southwestern Kenya (approximately south of 1°N and west of 38°30'E)	1963-67	1:30,000 or 1:50,000
Most parts of the Highlands and the Coastland	recently	1:25,000

In parts of Kenya aerial photographs have been taken on repeated occasions since 1954. In such cases the photographs can be used for comparisons and studies of changes in landscape, vegetation and cultivation. Illegal cutting of forest can be revealed. An increase in the erosion of gullies and rivers can also be quantified.

The lengths measured on an aerial photograph are approximate, and true only in the centre of the photograph, where the camera was directly above. As with dye-prints, the photographic paper can shrink, also causing minor errors in the scale.

The aerial photographs have been taken from an aeroplane flying at a height of 30,000 feet, in strips across Kenya from west to east and from east to west. Every strip consists of a series of photographs overlapping each other by 60 % (upper picture p. 159). Such overlapping pictures can be used for stereoscopic studies.

The price of aerial photographs from the Survey of Kenya depends on the number purchased: 1-20 shs 15/- each, 21-50 shs 13.50, 51-100 shs 12/- and more than 100 shs 10.50.

### Aerial photographs used with a stereoscope

Due to the fact that we have two eyes, we can see hilly country from two directions. In this way we have a 3-dimensional relief picture or a stereo-view.

A stereoscope is an instrument, which imitates such a visual action. Two overlapping aerial photographs are needed, put close to each other in the same way as our eyes would see the picture — or in other words, our eyes having attained the necessary focus and convergence of viewing.

A pocket stereoscope (type Casella, shs 200) consists of a pair of lenses mounted on a stand which can be put above two overlapping photographs. The lenses are somewhat oblique. If the photographs are moved in relation to each other, a position of the photographs can be found, when your eyes, due to the lenses, will see the two photographs as only one convergent photograph, i.e. a stereo-view, as your eyes would see the country. Now a 3-dimensional model will be visible below the stereoscope, i.e. hills and valleys will stand out with altitude and depth. The lenses have a magnification of 2 times.

How to use the stereoscope step by step (see the lower picture on the next page):

- 1) Take a pair of overlapping aerial photographs and lay them so the details of the left hand picture lie exactly over the details of the right hand picture.
- 2) Select a well recognized item and pull the photographs apart, until the two images of the item have the same distance between them as the distance between the pupils of your eyes (something between 55 and 75 mm, which can be measured by another person using a ruler).
- 3) Put the stereoscope with the lenses over the items and parallel to the line of flight.
- 4) Look through the lenses in the same way as you look through a pair of glasses. Keep the left hand photograph still, using your left hand. Use your right hand to adjust the right hand photograph until the two photographs converge into one. Now you have a 3-dimensional relief model.

Fig. 31

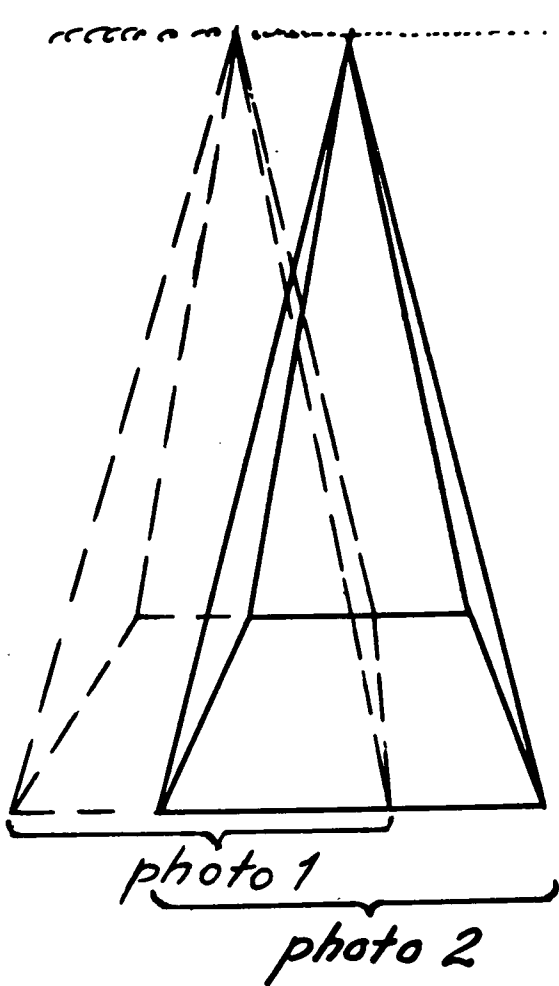

*Two aerial photos taken from an aeroplane*

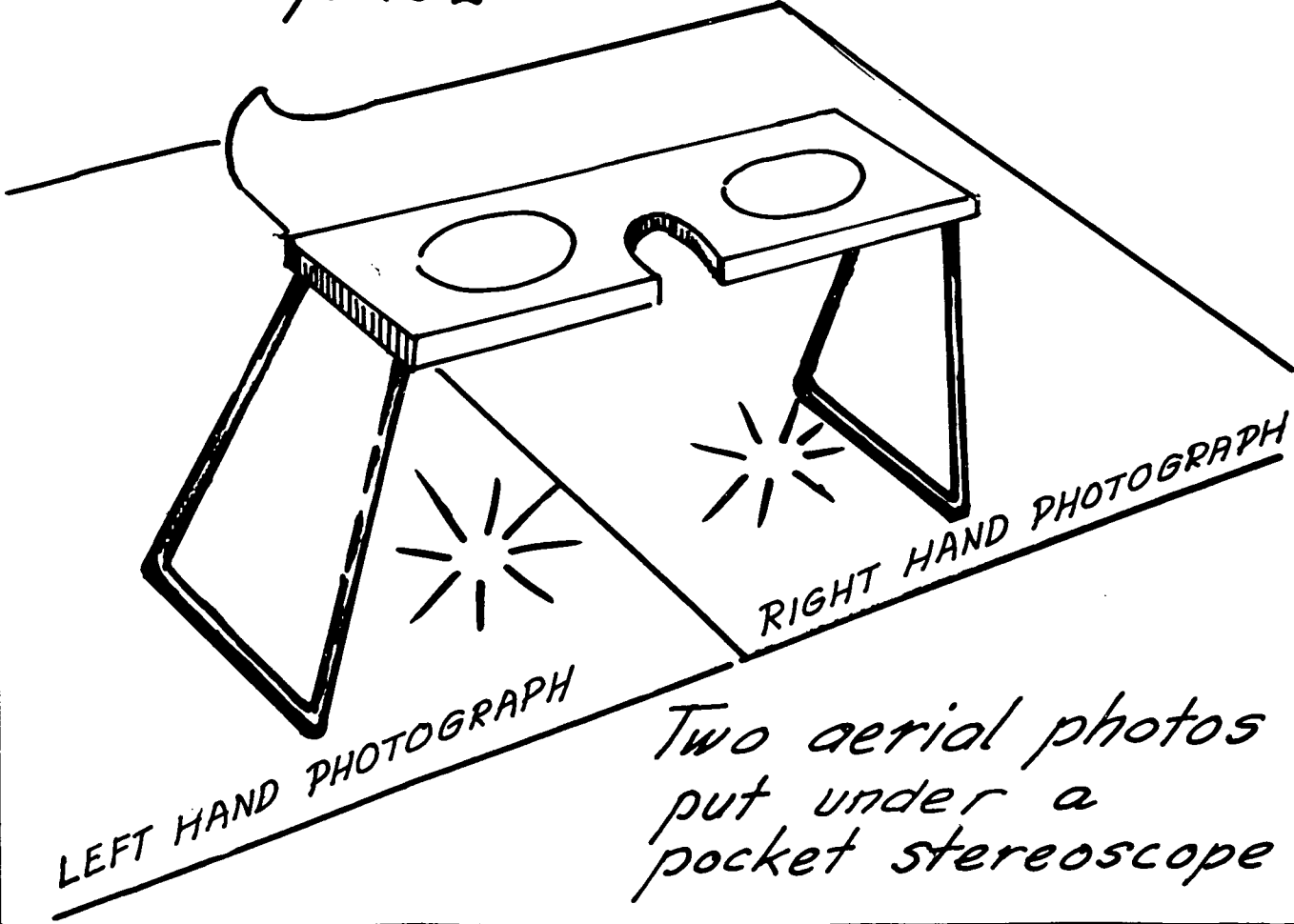

*Two aerial photos put under a pocket stereoscope*

## SATELLITE MAPS

Since 1972 an Earth satellite moving round the Earth has been used for mapping purposes. In January 1975 a second satellite, LANDSAT 2, was launched into space by NASA (National Aeronautic and Space Administration) from the U.S.A.

The satellites are in orbits 800-900 km above the surface of the Earth passing over the poles. Each orbit takes 103 minutes, i.e. 14 orbits per day. It takes 18 days for every satellite to cover the whole of the Earth's surface. At about 9.30 a.m. every 9th day a satellite hovers over Kenya.

This mapping method, called remote sensing, records the visible, as well as the infra-red light energy reflected by the ground and its vegetation. The satellite has T.V.-cameras and a multispectral scanner. The image data together with the data giving the position of the satellite, is recorded electronically by ground stations in the U.S.A. The data is stored on magnetic tapes and any picture can be processed by request.

On the satellite map different colours show different reflections of energy from the ground and the vegetation. Forest gives a red colour, water - black or blue, dry vegetation - yellowish blue, bare soil - pale green, rock - grey, etc. Different states of crops, e.g. healthy or diseased crops, reflect infra-red energy in different ways.

the scale is 1:1,000,000 (1 mm on the photograph = 1,000 m on the ground), i.e. only large farms and fields are visible (the smallest size 30-40 ha). Satellite maps can show the extent of flooded areas, the pollution by red soil-bearing river water of the sea, eroded bare soil, illegal deforestation, types of crops, stages of crop development, etc. The phenomena mentioned are all recorded at the same time over large areas.

The disadvantages are: 1) the small scale, 2) that the mapping is repeated on specific days with intervals of 9 days, and 3) that it takes about one month to have a satellite map delivered.

Satellite maps can be purchased from Eros Data Center, Sioux Falls, South Dakota 57198, U.S.A. In 1974 the price per sheet was US \$ 12 (= KShs 100).

PRACTICALS ON TOPOGRAPHICAL MAP IN SCALE 1: 50,000

1) Recognize on the map the following items, if any:

- |                |               |
|----------------|---------------|
| - roads        | - forests     |
| - houses       | - escarpments |
| - watercourses | - valleys     |

2) Find the distance between two points on the map.

Measure the distance in millimetres using a ruler, e.g. the distance between two rivers is 120 mm. As the scale is 1:50,000 (which means that 1 mm on the map is 50,000 mm = 50 m on the ground), the distance between the rivers is  $120 \times 50 \text{ m} = 6000 \text{ m}$ .

3) Draw the boundaries of a catchment area of a small river using the contour lines of the map.

4) Calculate roughly the size of the catchment area in sq.km using the squares of the map or measure the area with a ruler.

5.a) Calculate the percentage slope between two contour lines somewhere on the map using the vertical interval.

Draw a straight line perpendicular to the two contour lines.

Measure the distance between the contour lines.

Example: Check the V.I. of your map, e.g. the V.I. of contour lines is 20 metres. If the distance between the contour lines on the map is 3 mm, it is  $3 \times 50 \text{ m} = 150 \text{ m}$  on the ground.

Thus % of slope is  $\frac{20 \times 100}{150} = 13 \%$ .

5.b) Repeat the same thing on an area where you have several contour lines.

5.c) As areas with a slope less than 2 % do not need soil conservation, calculate also this limit in the same way ( V.I. = 20 metres):

$$\text{H.I.} = \frac{\text{V.I.} \times 100}{s} \qquad \text{H.I.} = \frac{20 \times 100}{2} \qquad \text{Thus H.I.} = 1000 \text{ m.}$$

1000 m on the ground = 20 mm on the map.

Consequently, soil conservation is not needed in those areas, where contour lines are 2 mm or more apart.

Mark on the map an area where mechanized soil conservation can be used:

Conditions: Assume that mechanized soil conservation can be used on slopes less than 14 %.

It is 20 m between the contour lines of the map.

Formula:  $H.I. = \frac{V.I. \times 100}{s}$        $H.I. = \frac{20 \times 100}{14}$       Thus  $H.I. = 143$  m.

As 50 m on the ground = 1 mm on the map, the distance required on the map will be  $\frac{143}{50} = 2.9$  mm rounded to 3 mm.

Now you can mark those areas on the map, where the contour lines are more than 3 mm apart, i.e. the slope is less than 14 % and mechanized soil conservation possible.

#### PRACTICALS ON AERIAL PHOTOGRAPHS

1) Identify on the photographs the following items, if present:

- cultivated areas
- forest areas
- grazing areas
- areas with strip cropping
- roads
- houses and farms
- watercourses and erosion of banks
- single trees
- terraces
- escarpments and valleys
- gullies where erosion is developing and old gullies now stabilized.

2) Find out the need for a cutoff drain somewhere on the photograph.

Draw this cutoff drain on the photograph considering topography and houses as well as outlet of water ( use a pencil and not a pen).

X INSTRUMENTS

C O N T E N T S

	pages
1. The line level	
Construction details	162 - 163
Setting up the instrument	162 , 164
Checking the accuracy of the spirit level	164
How to measure with the line level	164 - 166
Layout of terraces	167
Practicals	168
Another type of line level for the layout of terraces	168
2. The quickset level	
Construction details	169 - 170
Setting up the instrument and how to use it	170 - 171
Checking the accuracy of the quickset level	172
Measurements with the quickset level	173 - 175
Practicals	175
A simplified type of quickset level	175
Profile levelling	176
3. The clinometer	
Construction details	177
How to measure with the instrument	177 - 182
Practicals	183
4. Comparison of the different methods	183



## THE LINE LEVEL

### Construction details

A line level consists of two line level sticks, a spirit level and a cotton string.

#### The line level sticks

The line level sticks are made of hardwood (e.g. Camphor tree or Meru Oak), 1 inch x 1 1/2 inches and 4 feet long. See Fig. 32 a and 32 b on the next page.

A triangular piece of wood is screwed onto the stick, reaching 8 inches above the foot of the stick. This is to prevent the stick from sinking into the ground and to have the graduations of the stick above the grass and other vegetation on the ground.

Above the wooden triangle the stick has 12 graduations up to an 0-mark at the top of the stick, every graduation marking a distance of 3 inches. The graduations are marked by saw cuts 1 mm wide and 1 mm deep. In the cuts you can fix the cotton string.

Some line level sticks have figures marked above every graduation cut, showing the total length from the 0-graduation mark: 3", 6", 9", 1', 1'3", 1'6", 1'9", 2', 2'3", 2'6", 2'9" and 3'. Using these figures the line level stick can be used as a measure.

#### The cotton string

The string between the sticks shall have a length of 25 feet, but for tying the string onto the line level stick some extra feet of string are needed, e.g. totally 28 feet.

#### The spirit level

The spirit level is the usual type used by builders for checking horizontal surfaces. It consists of a plastic or metallic tube containing the spirit level, with two hooks at each end (Fig. 32 d) so the spirit level can be hooked onto the cotton string put up between the line level sticks.

### Setting up the instrument

Three persons are needed to handle the line level. A loop of the string is tied by person No. 1 at the top (0-graduation mark) of one of the line level sticks. The string is then pulled straight to the other stick, so the distance will be 25 feet. The second stick is held vertically by person No. 2. Person No. 3 hooks the spirit level

The line level

Fig. 32

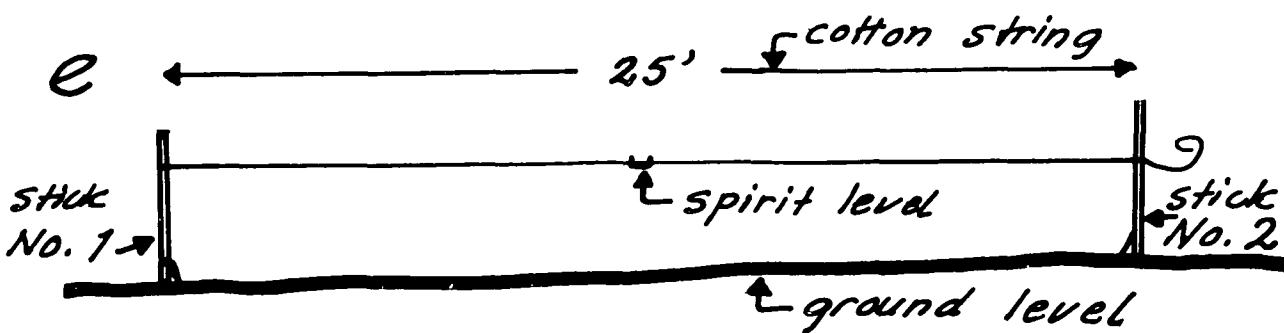
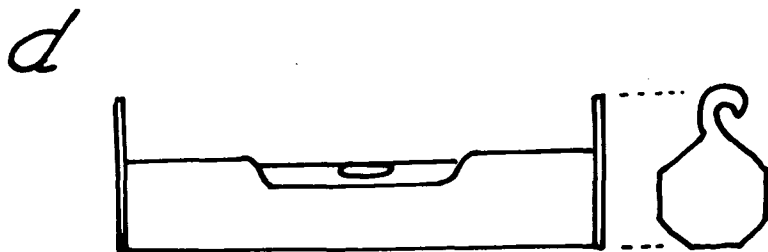
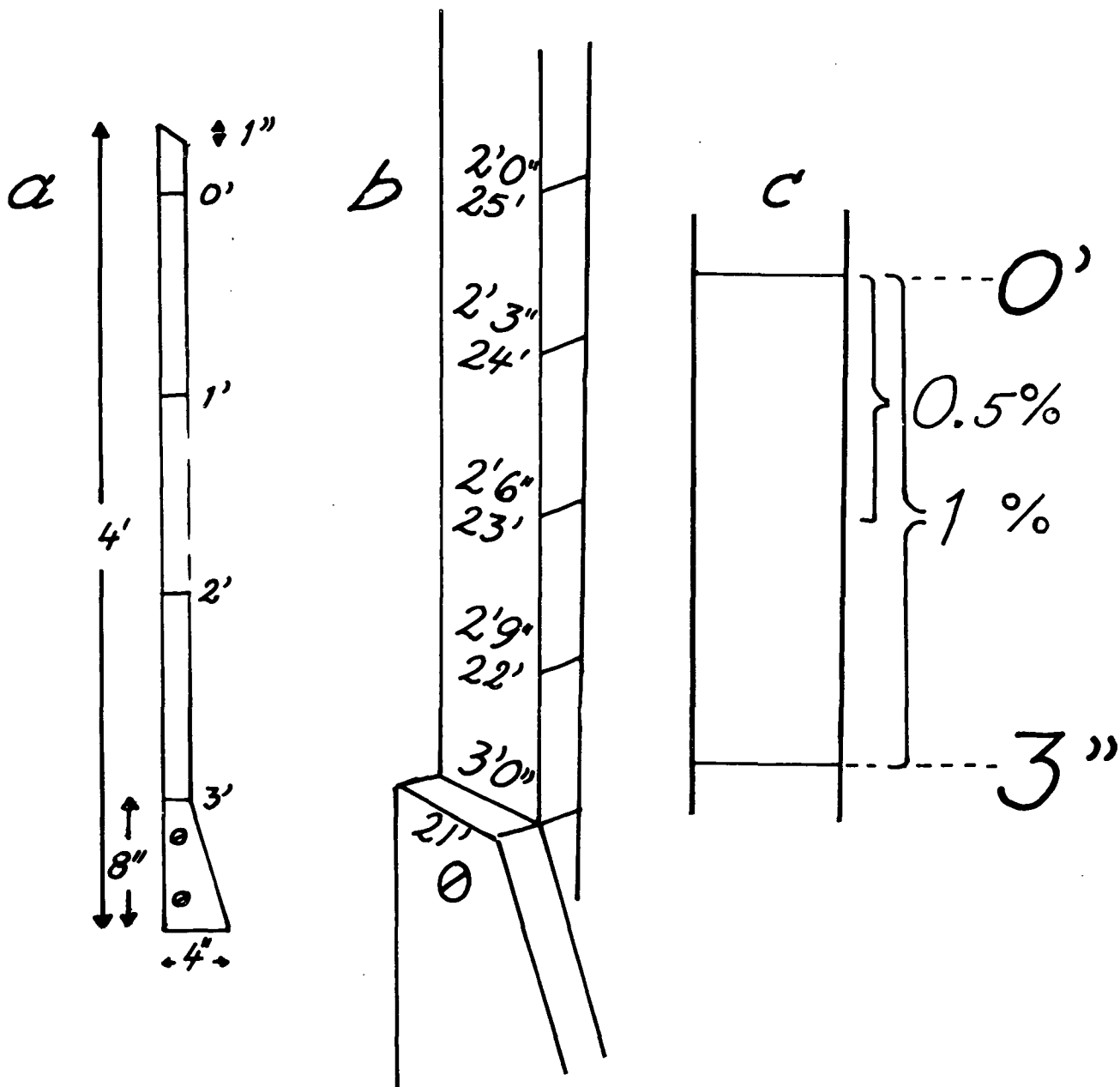

exactly onto the centre of the string (Fig. 32 e, p. 163).

To get the same height for the two sticks, person No. 2 has to move his stick with the cotton string fixed to the 0-graduation, until the air bubble of the spirit level, read by person No. 3, is exactly in the middle of the scale.

#### Checking the accuracy of the spirit level

To check the accuracy of the spirit level you have to repeat the last exercise, until the air bubble comes to the centre. After that you remove the spirit level from the string, turn it  $180^\circ$  and hook it back onto the string. If the bubble now comes to the centre again, the spirit level is accurate. If not, the spirit level cannot be used.

#### How to measure with the line level

To use the line level on a slope the lower stick should always have the cotton string tied to the 0-graduation at the top of the line level stick. On the other line level stick the cotton string should be lowered, until it is horizontal according to the spirit level.

Each of the 12 graduations on the line level stick is 3 inches from the next. The length of the cotton string between the two sticks is 25 feet =  $25 \times 12$  inches = 300 inches. This means that every change in graduation is  $3:300$  or  $1:100 = 1\%$  (Fig. 32 c, p. 163).

As there are 12 graduations, slopes up to 12% can be measured with the distance between the sticks being 25 feet. If the slope is steeper than 12%, the cotton string distance of 25 feet can be halved to 12.5 feet (= 150 inches). Now every graduation will be  $3:150$  inches or  $1:50 = 2:100 = 2\%$ . With a string length of 12.5 feet slopes of up to 24% can be measured.

And with a string length of 6.25 feet (a quarter of 25 feet) every graduation will be 4%, permitting the measurement of percentage of slopes up to 48%.

#### Measuring the percentage slope.

See the figure on the next page. Move the string up and down along stick No. 2, until the spirit level indicates that the string is horizontal. Then read off the number of graduations below the 0-mark, e.g. 10.5 i.e. 10.5%.

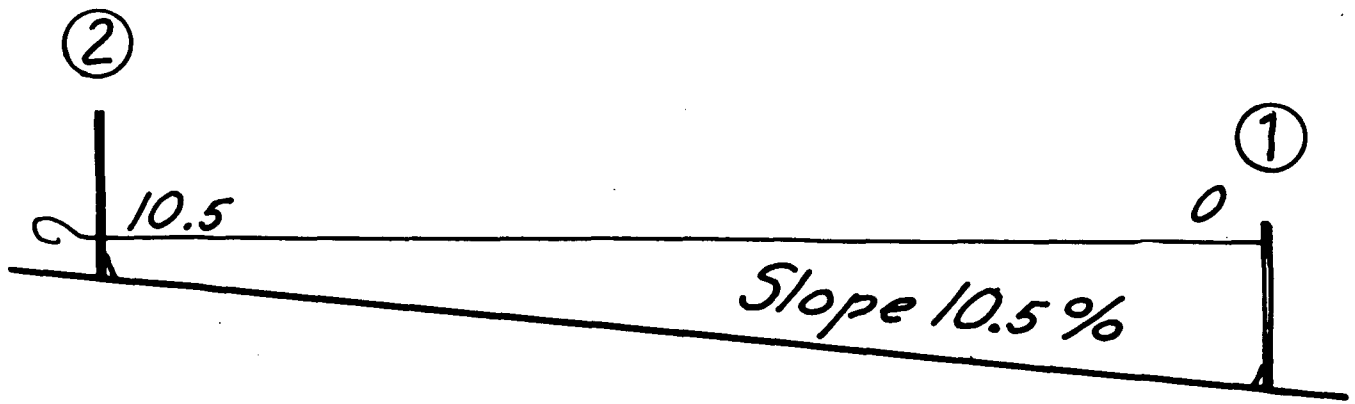

Measuring vertical intervals of existing terraces.

Now use the line level as a measure:

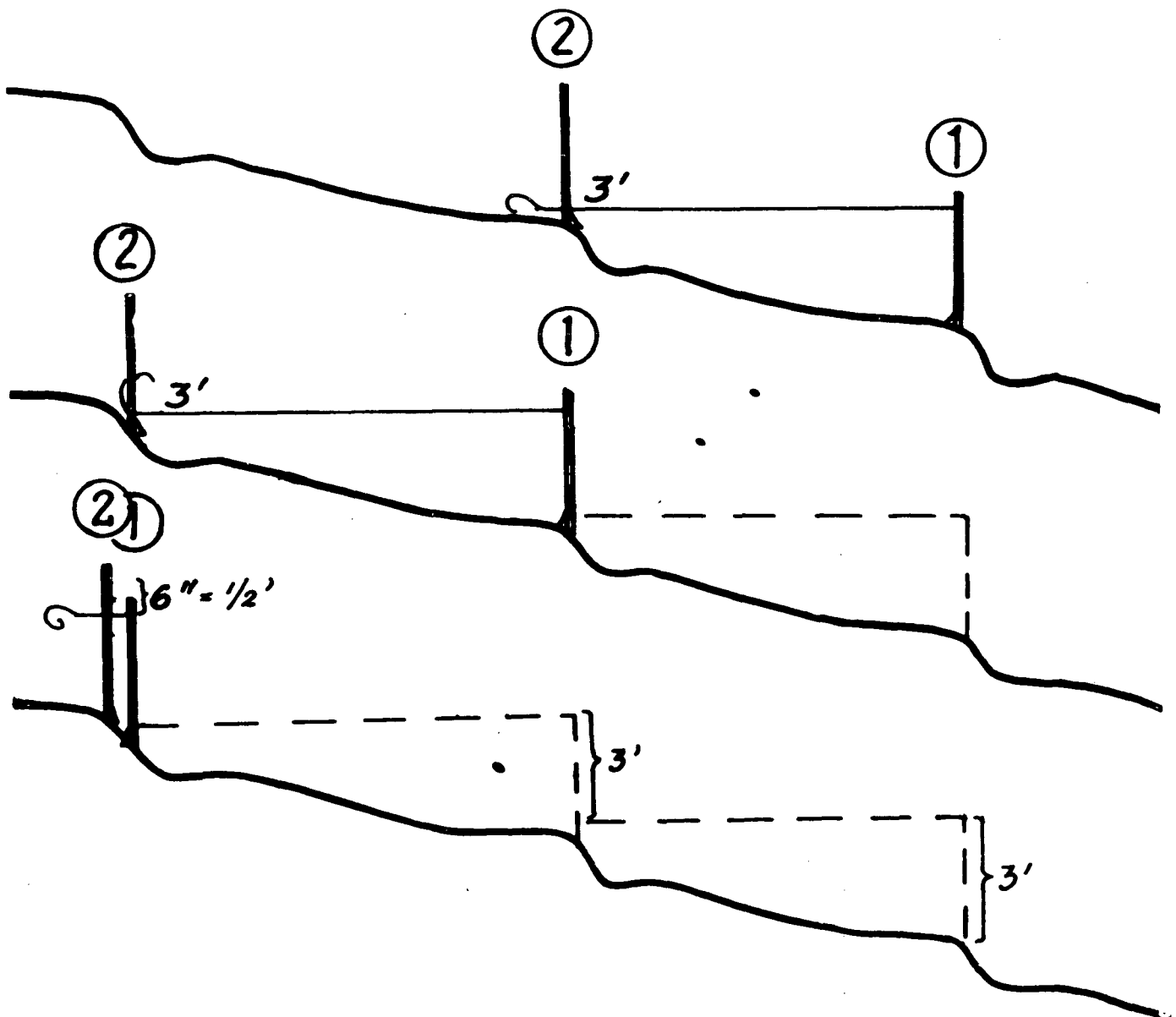

The vertical intervals between the terraces in the picture above: lower terrace 3 feet, upper terrace 3 feet 6 inches = 3.5 feet.

Note that you should measure between comparable parts of the terraces, e.g. the highest part of the ridge.

Setting out vertical intervals between new terraces using formulas.

First you should measure the percentage slope, e.g. 12 %, and calculate the V.I. for this percentage slope according to the formula  $V.I. = \frac{\% \text{ slope}}{4} + 2 = \frac{12}{4} + 2 = 5 \text{ feet.}$

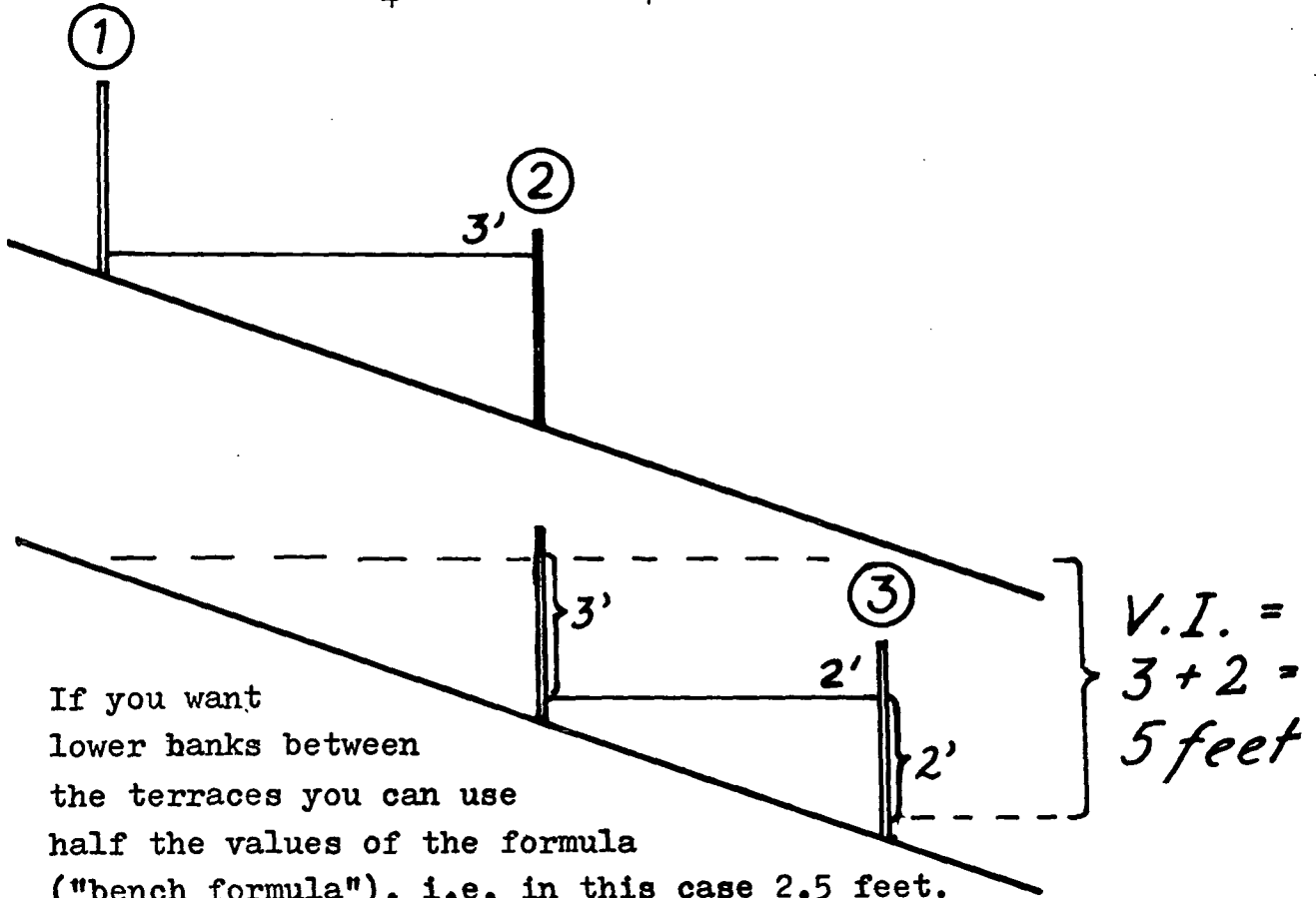

The horizontal intervals can be calculated from the vertical intervals (see p. 81). On old line level sticks the horizontal intervals according to the "bench formula" for low bench terraces were printed below the graduations:

0	3"	6"	9"	1'0"	1'3"	1'6"	1'9"	2'0"	2'3"
0	1'2'	62'	46'	37'	32'	29'	27'	25'	24'
2'6"	2'9"	3'0"							
23'	22'	21'							

This means that if the slope is 12 %, the horizontal interval of 21 feet can be read directly from the stick without any calculation.

With calculation using the bench formula:

$$HI = \frac{1}{2} \left( \frac{V.I. \times 100}{\% \text{ slope}} \right) \quad H.I. = \frac{1}{2} \left( \frac{5 \times 100}{12} \right) = \frac{1}{2} \times 42 = 21 \text{ feet.}$$

Measuring the gradient of existing terraces

You start at the outlet point of a graded terrace or a cutoff drain:

The lower stick should have the string at the top, and on the upper stick the string should be moved up and down the stick until the string is level. Then read the graduation on the upper stick. If it is one graduation, the gradient is 1 % (see the figures below). If it is half a graduation, the gradient is 0.5 %.

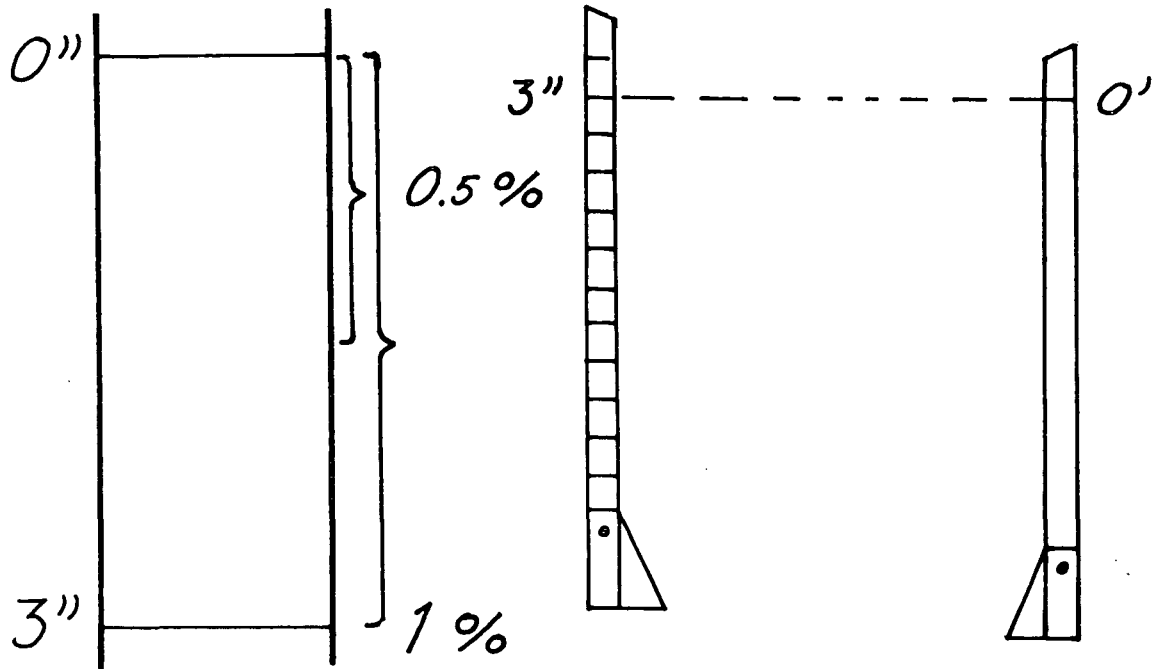

Layout of the gradient for a new terrace or a cutoff drain

If you want a 1 % gradient, you should put the string in the second cut on the upper line level = 3 inches = 1 %. See the figure above.

Layout work on a farm

As an example the calculation has given the V.I. to be 6 feet. The loam soil requires a gradient of 0.5 % on the terrace line. Start by pegging vertical intervals (A, B, C) down the slope; in this case the V.I. = 6 feet.

*Layout of vertical intervals  
Section*

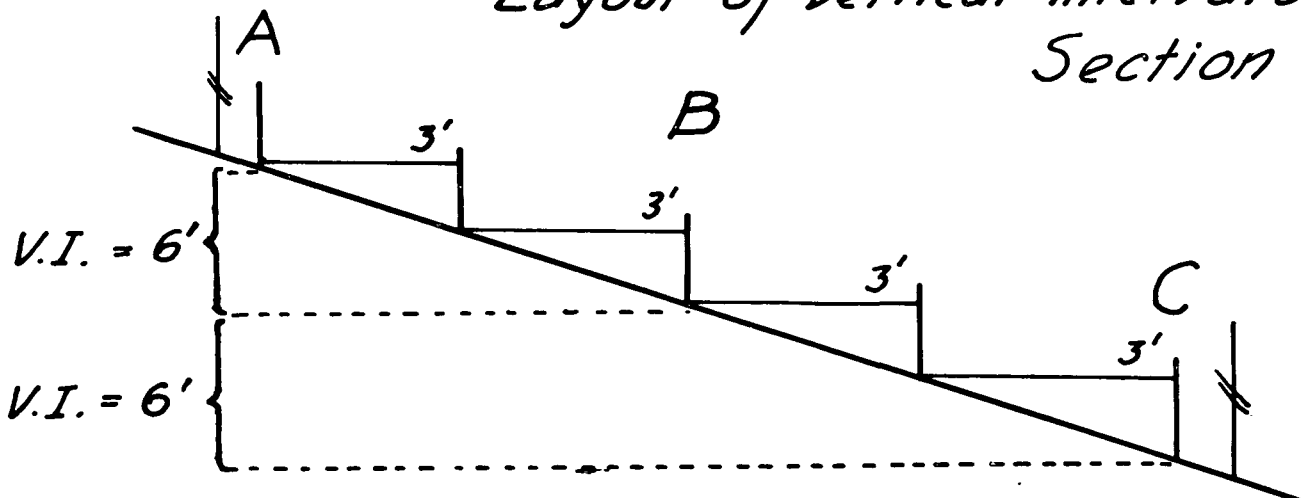

The next step in the layout procedure is to measure a gradient of 0.5 % for the terraces, starting from the vertical intervals set out down the slope:

### Layout of terraces. Plan

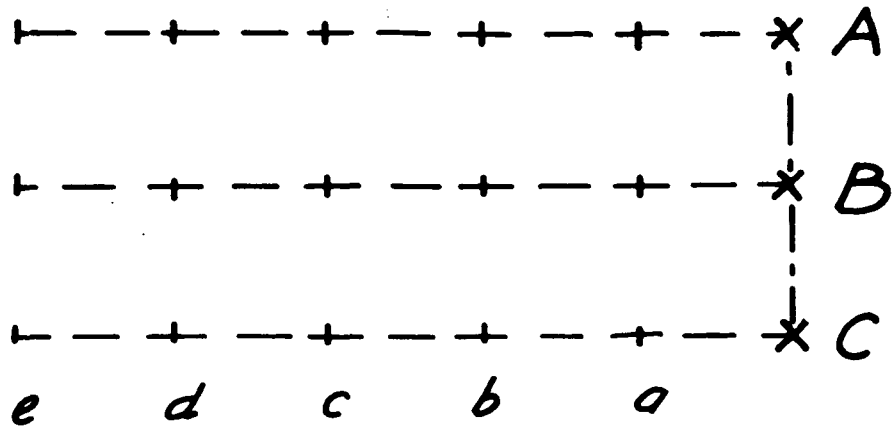

### Layout of terraces. Section

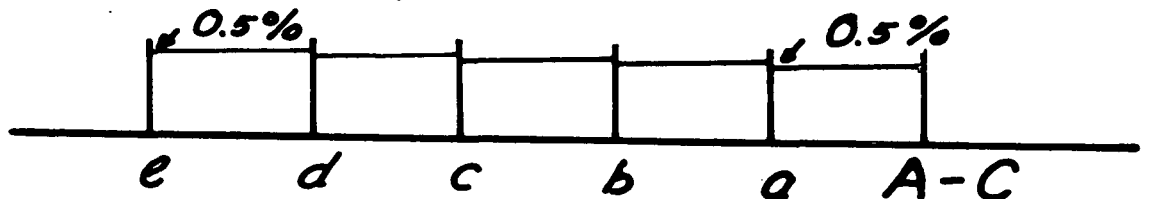

#### Practicals

1. Measurement of slopes less and more than 12 %.
2. Measurement of the V.I., the H.I. and the gradient of existing terraces and trying to find out which formulas were used initially.
3. Layout of terraces using a constant V.I. of 5 - 6 feet.
4. Layout of low bench terraces, comparing calculated H.I. with the H.I. marked on the line level stick.
5. Layout of terraces graded to 0.5 %, and repeating this work to find out the difference between the two measurements (testing the accuracy of the method you used).

#### Another type of line level (after Clayton, 1935)

The spirit level can also be used on a frame as shown in the drawing below. The wood should be light straight timber (e.g. 4 x 1 1/2 inches). If level terraces are required, the height should be equal at both ends of the frame. If a graded terrace is required, one leg of the frame has to be cut, e.g. for a grade of 0.5 % a shortening of 1 inch, for 1 % - 2 inches.

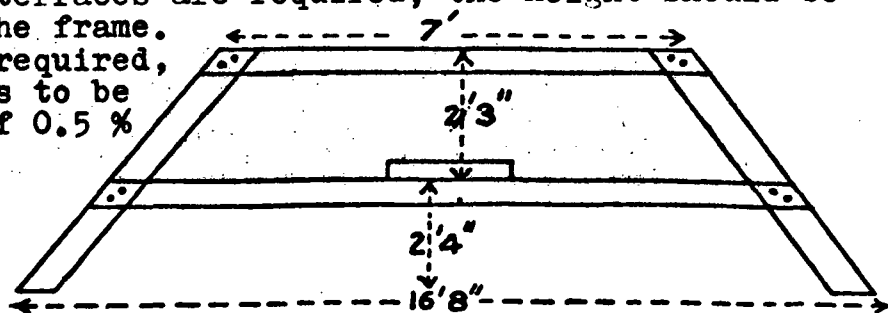

## THE QUICKSET LEVEL

### Construction details

When using a quickset level you need a levelling staff, a telescope on a tripod and usually a measuring tape.

### Levelling staff

Usually a length of 4 m is used, which can be shortened to half the length or shorter for easy transportation.

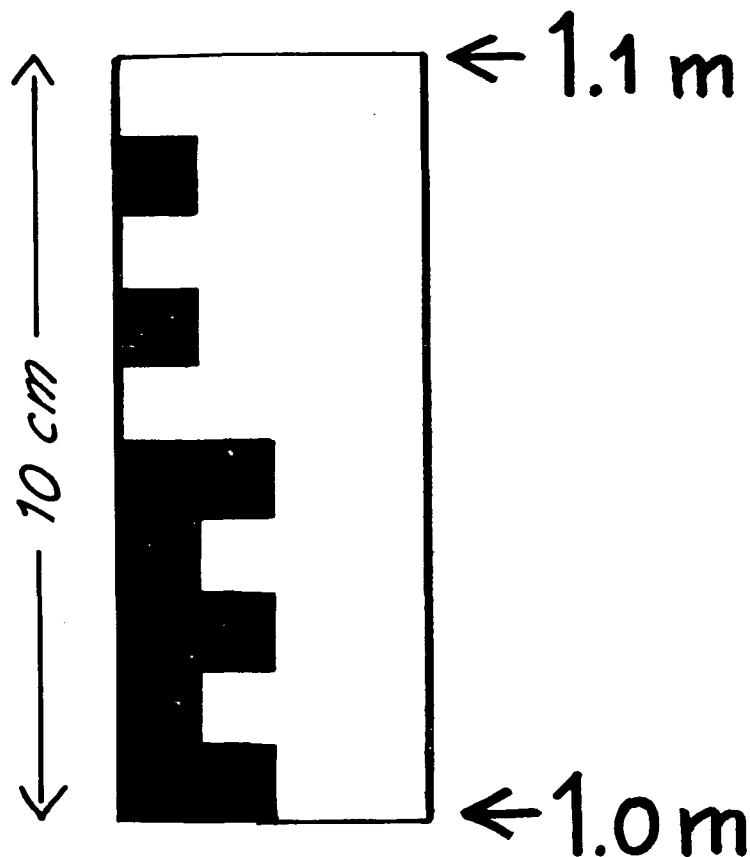

The staff usually used for soil conservation work has graduations in centimetres, with centimeter marks arranged in groups, making it easy to read. See the figure to the left. Only figures for metres and decimetres are marked on the staff.

When reading the staff with the telescope, the 0-mark should be on the ground. The figures are written upside down, because the lens of the telescope itself turns the figures upside down (compare the slide in a projector).

When laid on the ground, the graduated side of the staff should face upwards to prevent the scale from being damaged.

### Measuring tape.

The distance can be read from the instrument explained below, or can be measured with a stainless steel tape on a frame. A practical length is at least 10 m, but not more than 30 m. When moving from point to point the tape should be carried above the ground so as not to damage the graduations and the figures on the tape. After usage the tape should be cleaned and dried.

### The telescope

The telescope has a spirit level and screws for adjustment, illustrated in the figure on the next page.



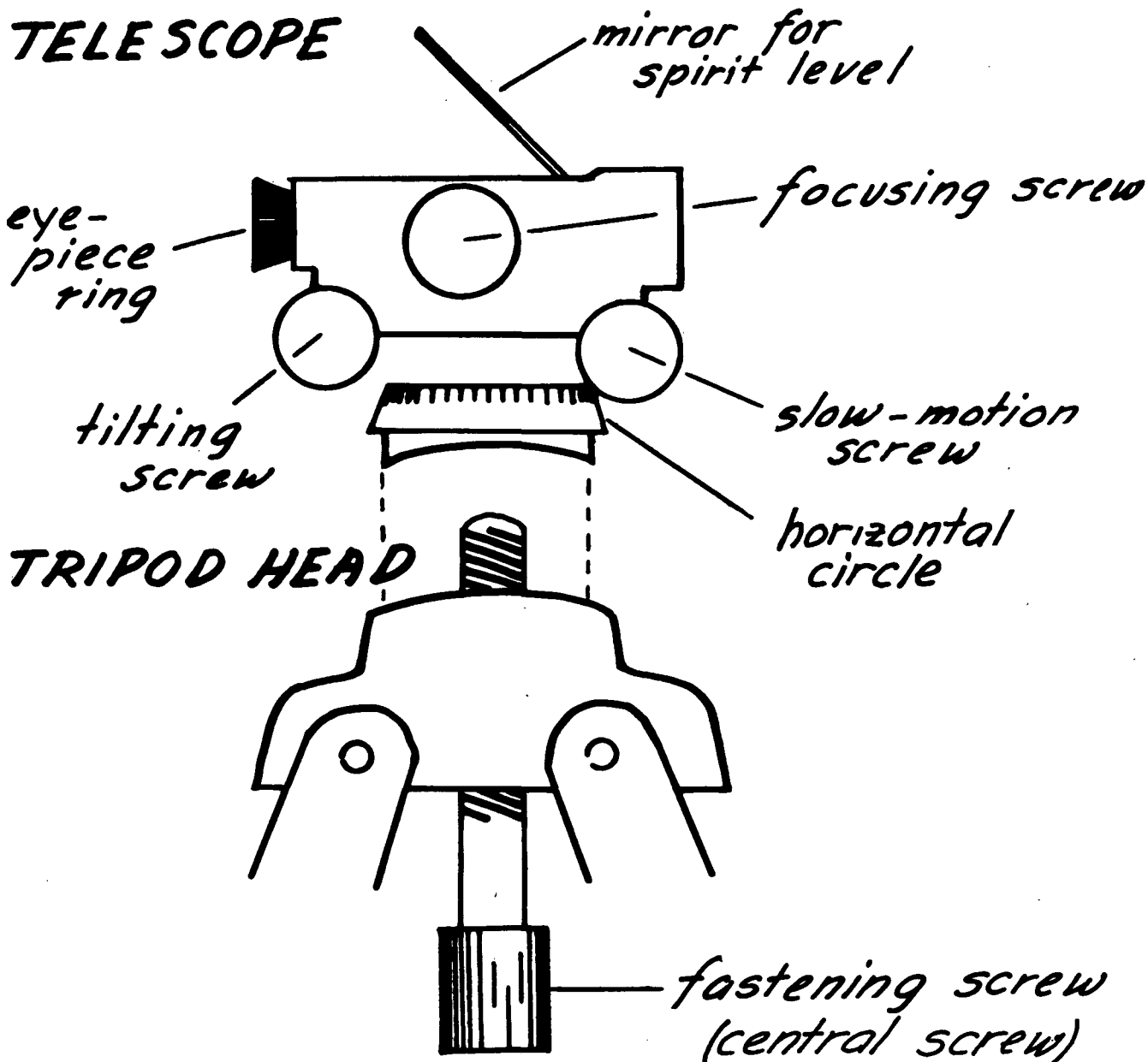

Setting up the instrument and how to use it

1 Setting up

- 1.1 Set up the tripod firmly on the ground. Loosen the fastening screw and remove the plastic cap over the tripod head.
- 1.2 Unpack the telescope and then close the box.
- 1.3 Place the telescope on the tripod head and fasten with the fastening screw.
- 1.4 After loosening the central screw again, shift the telescope over the spherical surface of the tripod head until the air bubble in the bull's eye level (visible on the front of the telescope) is centered, and then fasten the central screw again.

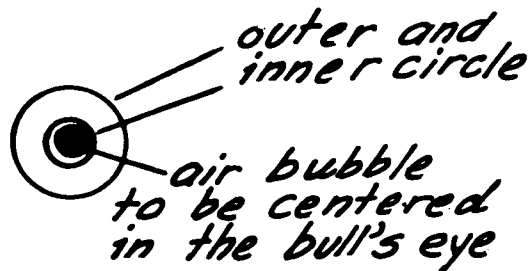

## 2 Focusing

2.1. To obtain a sharp picture of the levelling staff (picture a on the right) focus the telescope by moving the focusing screw.

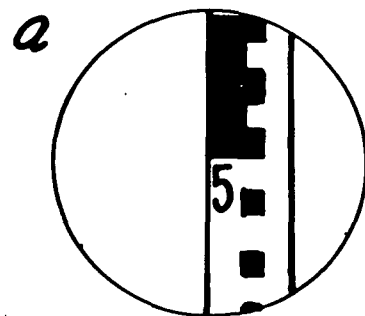

## 3 Reading the height

The glass of the lens has one vertical and three horizontal lines, one long and two short. **You can use the eye piece ring to make the hair lines appear sharper.**

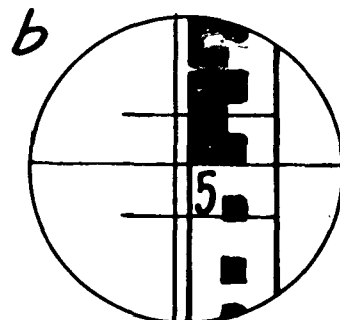

3.1. Center the vertical "hair" line (see picture b on the right) using the slow-motion screw.

3.2 Open the mirror (above the telescope) and use the tilting screw to centre the bubble between the lines as shown in picture c on the right.

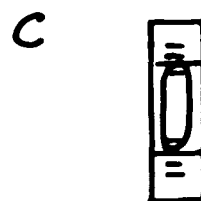

3.3 Take the reading of the central and long horizontal "hair" line on the staff (5.00 m in picture b).

## 4 Reading the distance

1 cm read on the staff through the telescope represents a distance between the telescope and the staff of 100 cm = 1 m

4.1 Move the tilting screw so that the lower "hair" line coincides with the nearest half or whole decimeter.

4.2 Read the number of centimetres between the lower and upper short horizontal "hair" lines (= distance in metres between telescope and staff). In picture b the reading is 4 rather than 3 centimetres, and thus the distance is 4 m.

## 5 Reading angles

Sometimes, especially for mapping purposes, angles between objects need to be measured. For this purpose you can use the horizontal circle of the telescope (see the figure on p. 170), if your instrument has such a circle. A magnifier on the movable scale facilitates the reading of degrees (see the picture on the right).

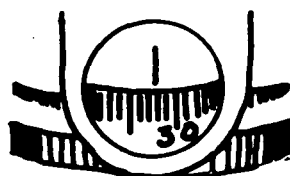

*The angle is 32°  
in this case*

Checking the accuracy of the quickset level

Read the telescope with the horizontal spirit level in two opposite directions, using a distance of about 30 m to each point as shown below:

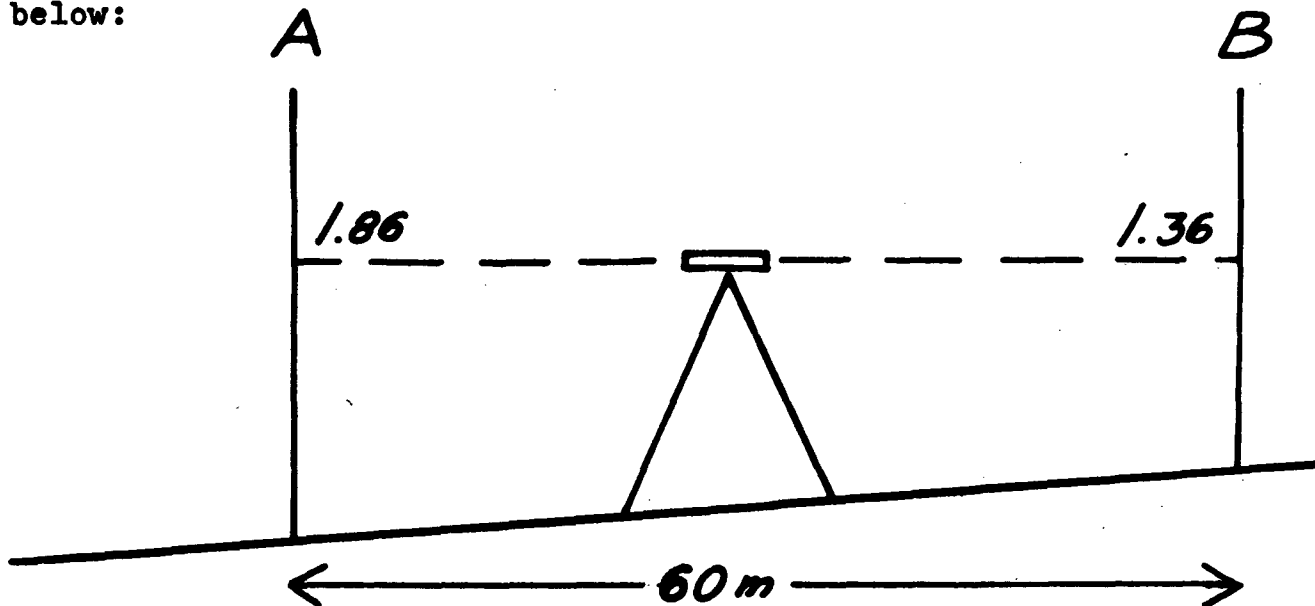

Readings on point A 1.86 m  
B 1.36 m

Difference in height between point A and B = 0.50 m.

After that move the telescope as close as possible (about 3 m) to one of the points and read again the points A and B as shown below:

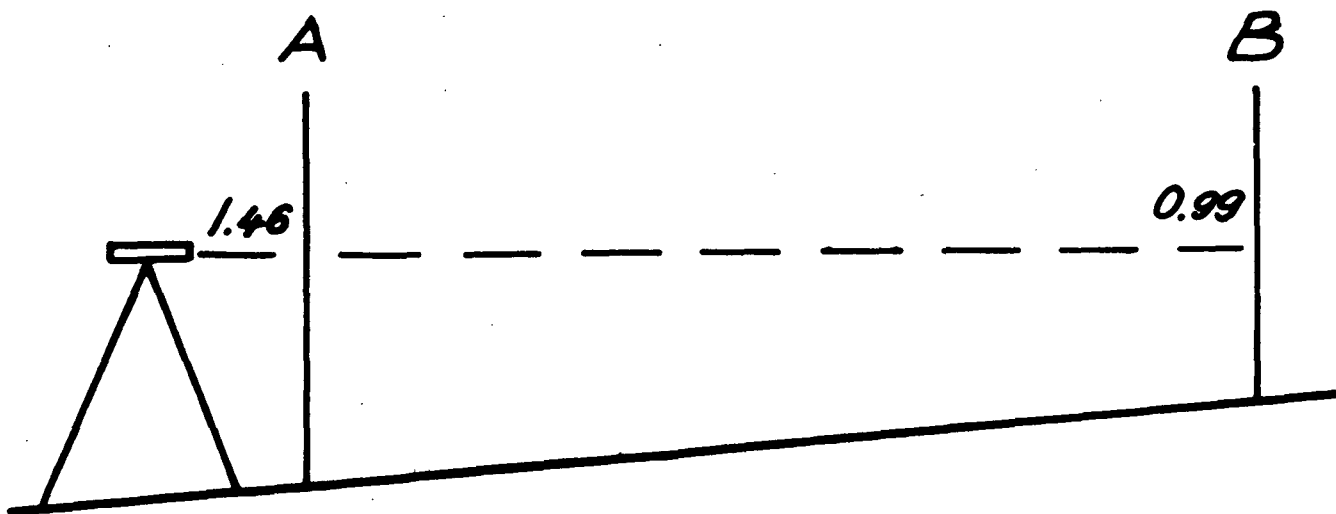

Readings on point A 1.46 m  
B 0.99 m

Difference in height between point A and B = 0.47 m.

Thus the error is the difference between 0.50 and 0.47 m = 0.03 m or 3 cm.

Measurements with the quickset level

Measuring the percentage slope

Introduction

A slope of 1 % = a drop of 1 m in a length of 100 m.

Instead let us use 10 m between the measuring points, then 1 % = a drop of 0.1 m in a length of 10 m.

Example

Set up the instrument as shown below:

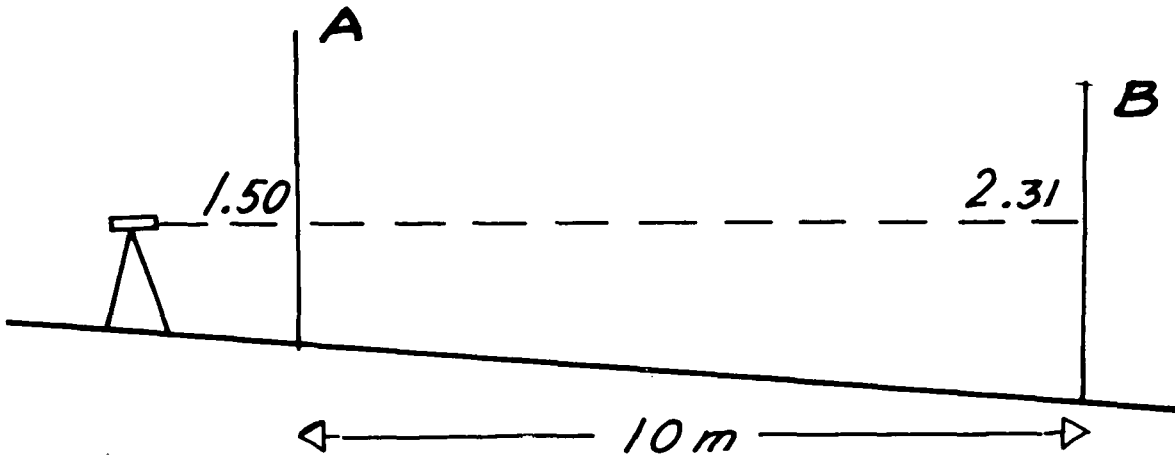

Reading A 1.50 m

B 2.31 m

Difference in height between points A and B = 0.81 m.

Thus the percentage slope = 0.81 m in 10 m, or

8.1 m in 100 m, or 8.1 %.

Setting out the vertical interval

Calculate the V.I. for a slope of 8 % =  $\frac{8}{4} + 2 = 4$  feet or 1.2 m.

Read the height on staff = 1.5 m. Add 1.20 m to that height (1.50 + 1.20 = 2.70 m) to have a difference in elevation of 2.70 - 1.50 = 1.20 m. Move staff up or down the slope until the level read in the telescope is 2.70 m.

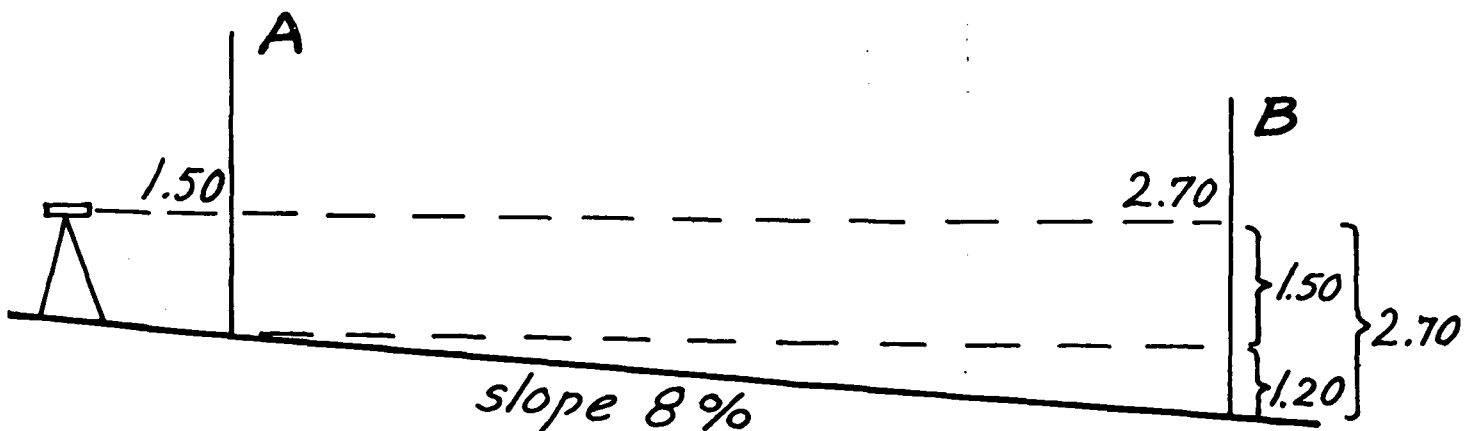

Layout of a level terrace

The height readings should all be the same. Move the staff up or down the slope until you have the same height along the terrace line.

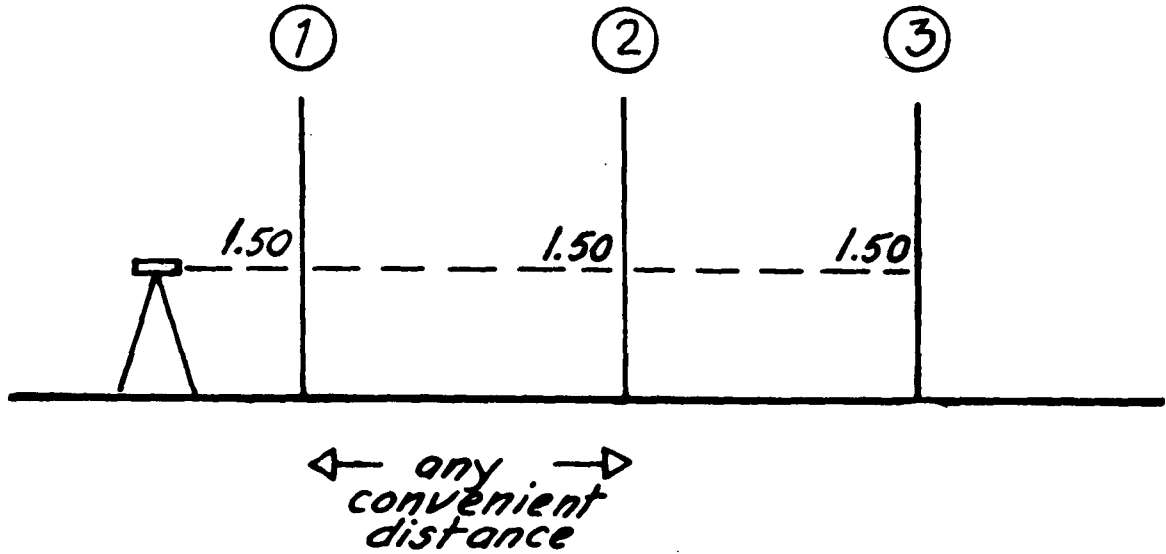

Layout of a graded terrace (or a cutoff drain)

Assume the spacings between the pegs to be 10 m.

Then 1 % = 10 cm on the staff

0.5 % = 5 cm on the staff

0.25 % = 2.5 cm on the staff

Walking up the gradient:

Point No.      Distance

Height to be read on the staff for  
the layout of a gradient of 0.5 %

1	0	1.50
2	10	1.45
3	20	1.40

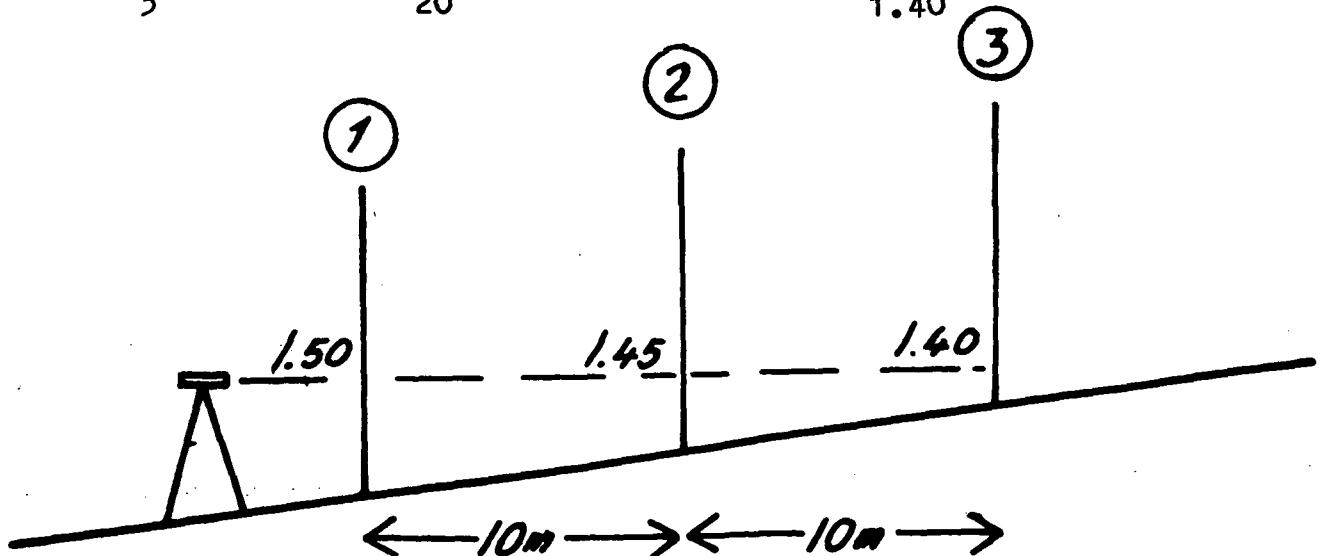

Walking down the gradient:

Point No.	Distance	Heights to be read on the staff for the layout of a gradient of 0.5 %
1	0	1.50
2	10	1.55
3	20	1.60

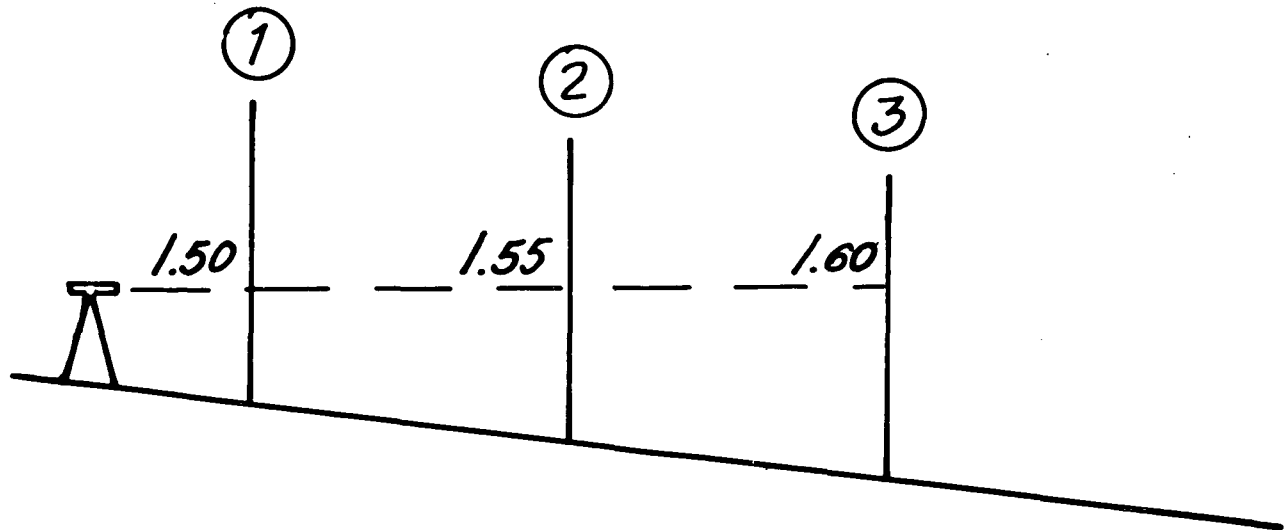

### Practicals

1. Check the instrument.
2. Measure the percentage slope.
3. Measure the V.I., the H.I. and the gradients of existing terraces. For the H.I. first use the telescope for measuring the distances. Repeat the measurements using the measuring tape.
4. Layout terraces using a constant V.I. of 6 feet (1.8 m).
5. Set out the V.I. of the terraces on the slope of practical No. 2, using the ordinary formula to calculate the V.I.
6. Lay out three terraces graded 0.5 %, and repeat this work to find out the difference between the two measurements (the accuracy of the method and your capability to use the instrument).

### A simplified type of quickset level

There is a simplified and cheaper type of quickset level, consisting of a small telescope with only one screw for focusing, and without a tripod.

This telescope can be used as a hand level held in front of your eye. To prevent your hand from trembling, the telescope can be held on top of a stick. The measurements are then taken as if you were using the quickset level described above.

Profile levelling (usually not needed in soil conservation)

Profile levelling is the measurement of the heights and the distances between a series of points along a profile, starting with a bench mark (= with known or assumed elevation).

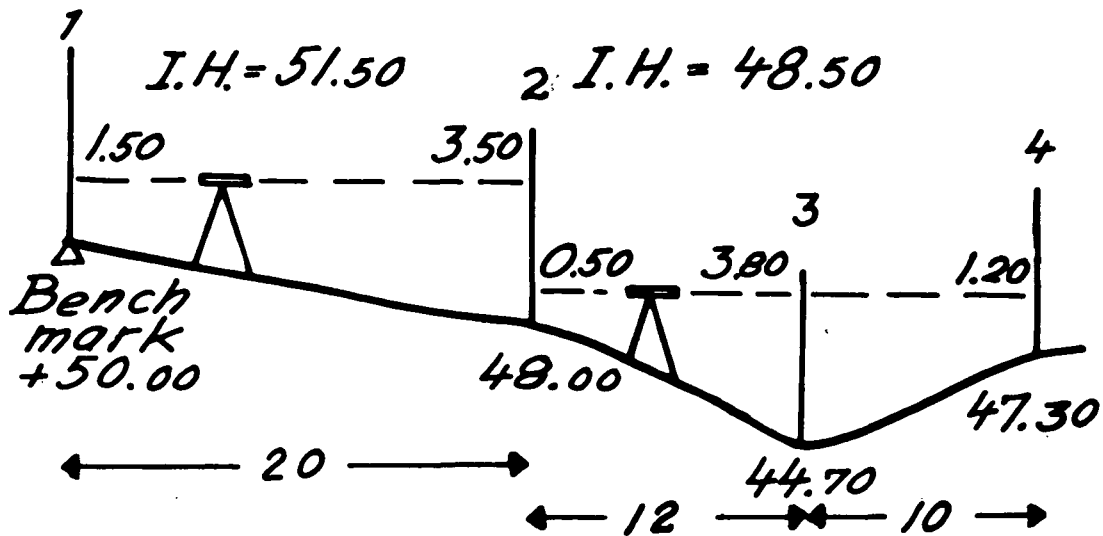

Back	Fore	I.H.	Elevation	Distance intervals	Distance total	Remarks
1.50		51.50	50.00	0	0	Bench mark on stone
0.50	3.50	48.50	48.00	20	20	Break point to valley
	3.80		44.70	12	32	Valley bottom
	1.20		47.30	10	42	Break point to level ground

1. Start at a bench mark, assumed having an elevation of 50.00 m. Place the staff on the bench mark, and read the height above the bench mark through the telescope, e.g. 1.50 m. The height of the instrument (I.H.) above the bench mark is  $50.00 + 1.50$  m. Write this figure in the I.H. column.
2. Move the staff to the next point and read the height on the staff, e.g. 3.50 m. This figure should be written on the next page in the Fore column. This point is 3.50 m lower than the I.H. Thus  $51.50 - 3.50 = 48.00$  m. Write this result in the elevation column.
3. The staff is only 4 m tall, so you have to move the telescope down the slope to read the staff after turning it. When turning the staff don't change its height above the ground (turning point and backsight reading). Read, e.g. 0.50 m, and write this in the Back column on the same line, because you are reading the same point. The I.H. is  $48.00 + 0.50 = 48.50$  m.
4. Move the staff to the next point and read, e.g. 3.80, to be written on the next line in the Fore column. The elevation of the point is  $48.50 - 3.80 = 44.70$  m.
5. The next point can be measured without moving the tripod. Foresight reading, e.g. 1.20, to be noted on the next line in the Fore column. I.H. is the same. The elevation is  $48.50 - 1.20 = 47.30$  m.

## THE CLINOMETER

### Construction details

Similar to the quickset level a clinometer is an instrument, which, if put in front of your eye, will give you a horizontal level from your eye (picture a on the next page). But with the clinometer you do not need a tripod, because you hold the instrument by hanging it on your thumb while reading it. Nor do you need a levelling staff, but a folding ruler, or another measuring stick has to be used.

Unlike the quickset level you can read the inclination directly from one point to another. This is why the instrument is called a clinometer.

The Swiss made Meridian clinometer does not have a spirit level but when held freely it assumes a position of equilibrium determined by its centre of gravity, and the horizontal level is perpendicular to the instrument. See the figure b on the next page.

Looking through the instrument you can see different vertical scales: for percentages, degrees of  $360^\circ$  and degrees of  $400^\circ$  as shown in figure c on the next page. All three scales have the same 0-level, i.e. the horizontal level from your eye. There are scales for inclinations above the 0-level (up to 100 %) and other scales for inclinations below the 0-level.

### How to measure with the instrument

#### Measuring the height

You should hold your instrument in front of your eye as shown in figure a on the next page. Your thumb (but not the instrument) can rest against your forehead.

To begin with you should train your eye to see the scale, and at the same time a point in the topography, which is the prolonged 0-level:

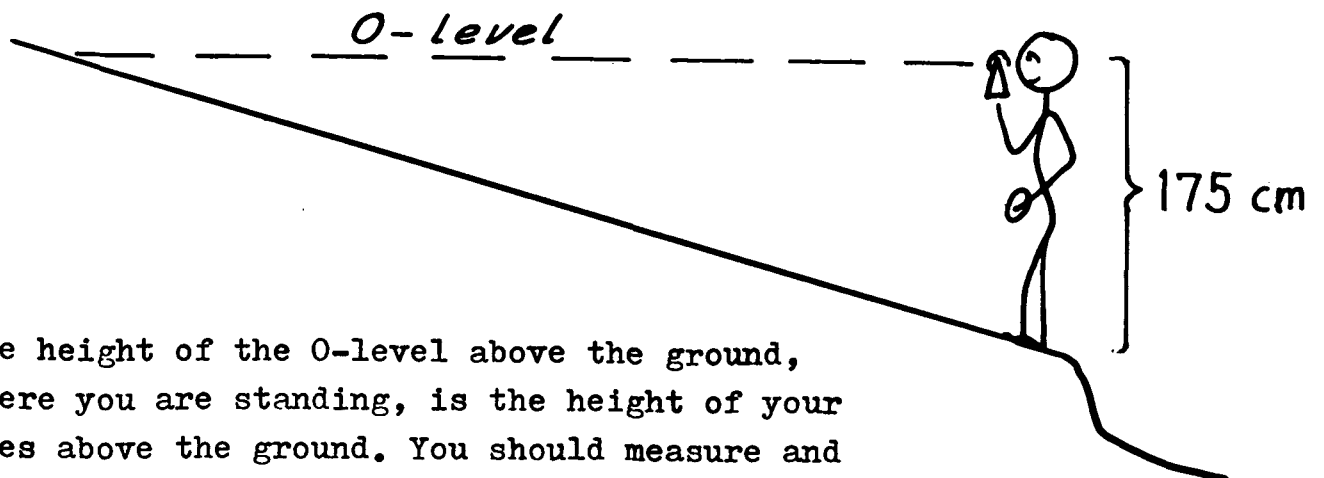

The height of the 0-level above the ground, where you are standing, is the height of your eyes above the ground. You should measure and know your eye height, e.g. 175 cm.



The clinometer

Fig. 33

a

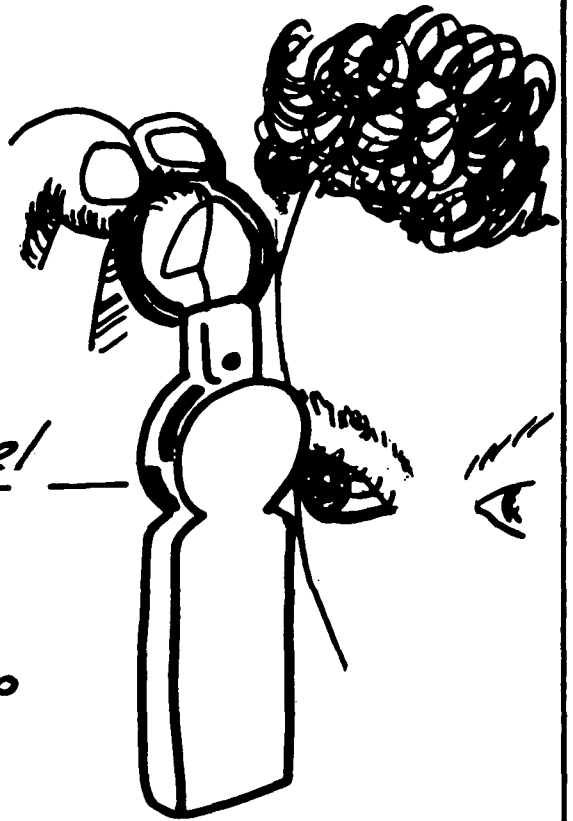

Horizontal 0-level

100% →

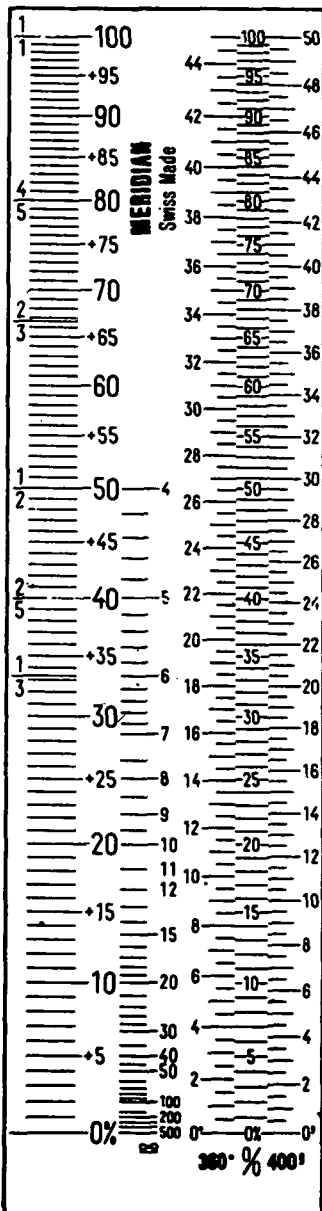

← 45°

c

0% →

b

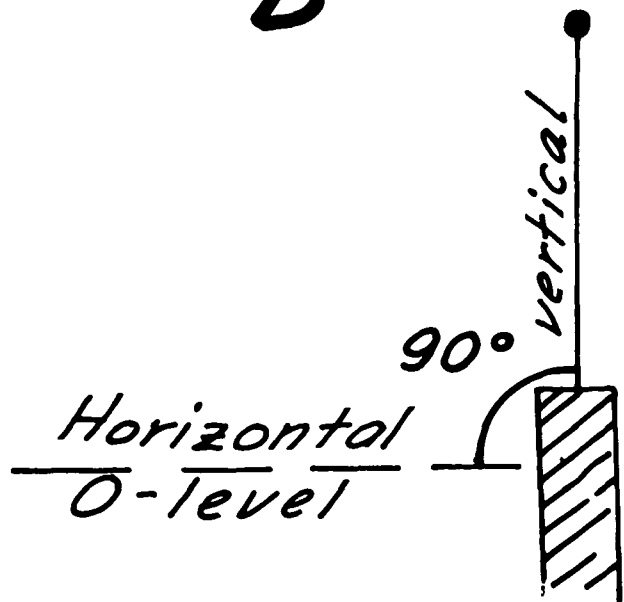

90°

Horizontal 0-level

You can use a measuring stick (folding ruler) for any height less than your eye height, e.g. 120 cm as shown below:

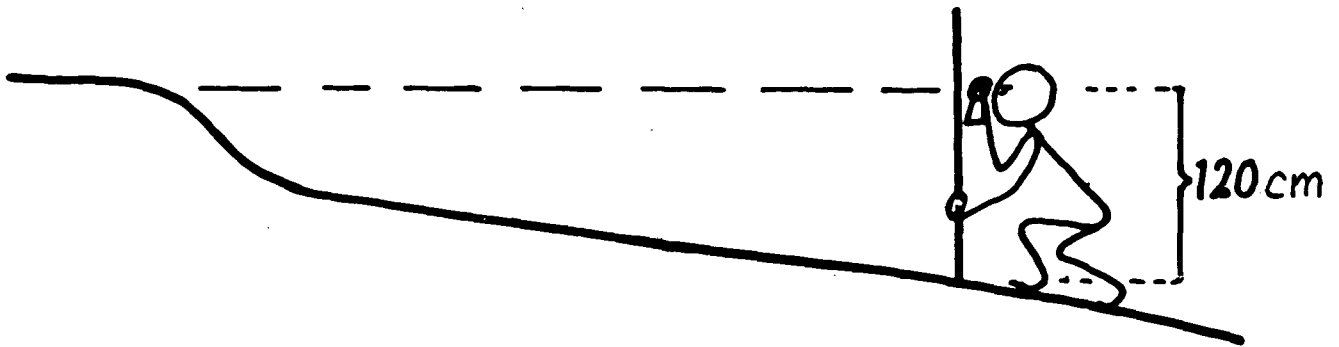

Measuring percentage slope

Firstly, you place a stick in front of you and mark your eye height on the stick:

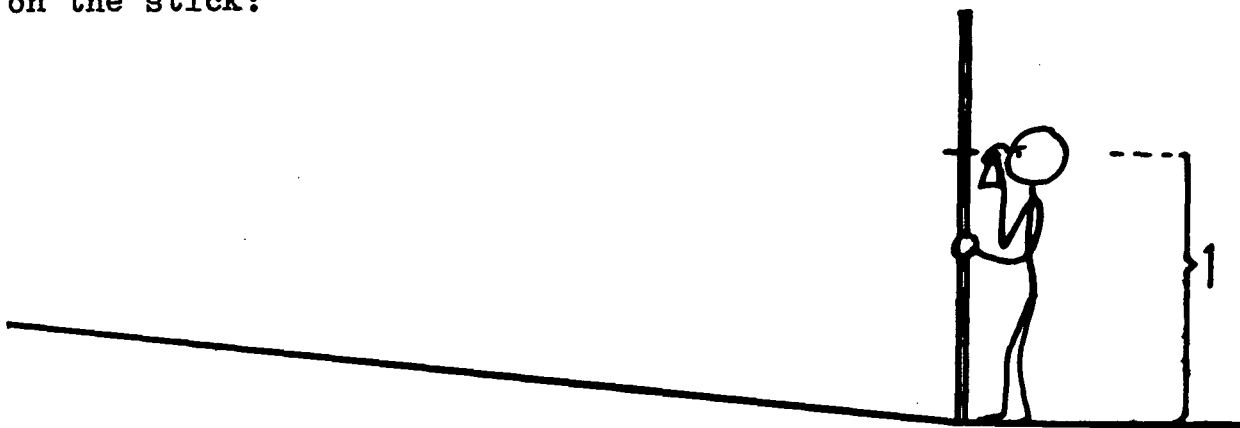

Secondly, ask somebody to move the stick up the slope, and read from the scale what percentage the mark is above your eye height, e.g. 8 % :

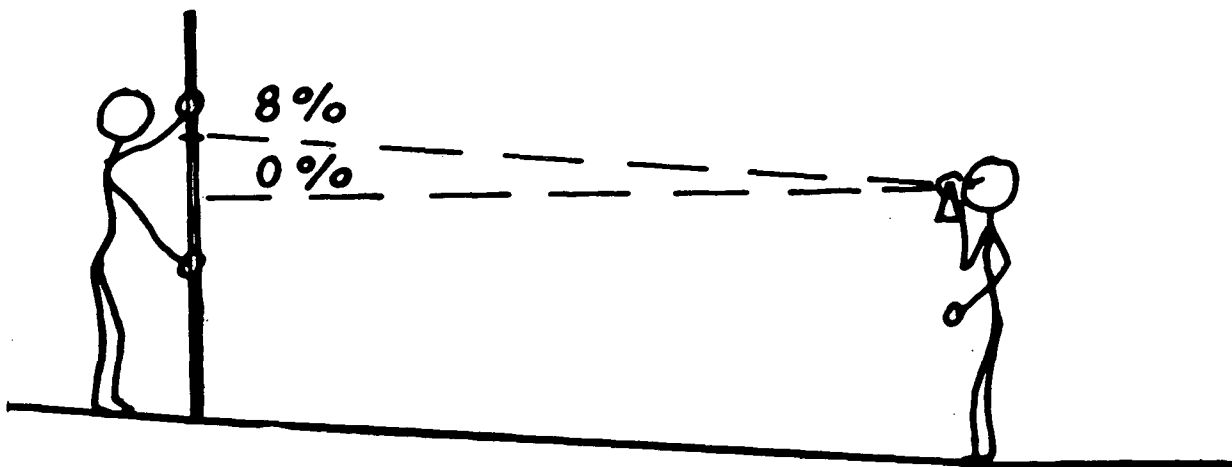

If you read down a slope, you should use the lower scale of the instrument, and read e.g. 15 %:

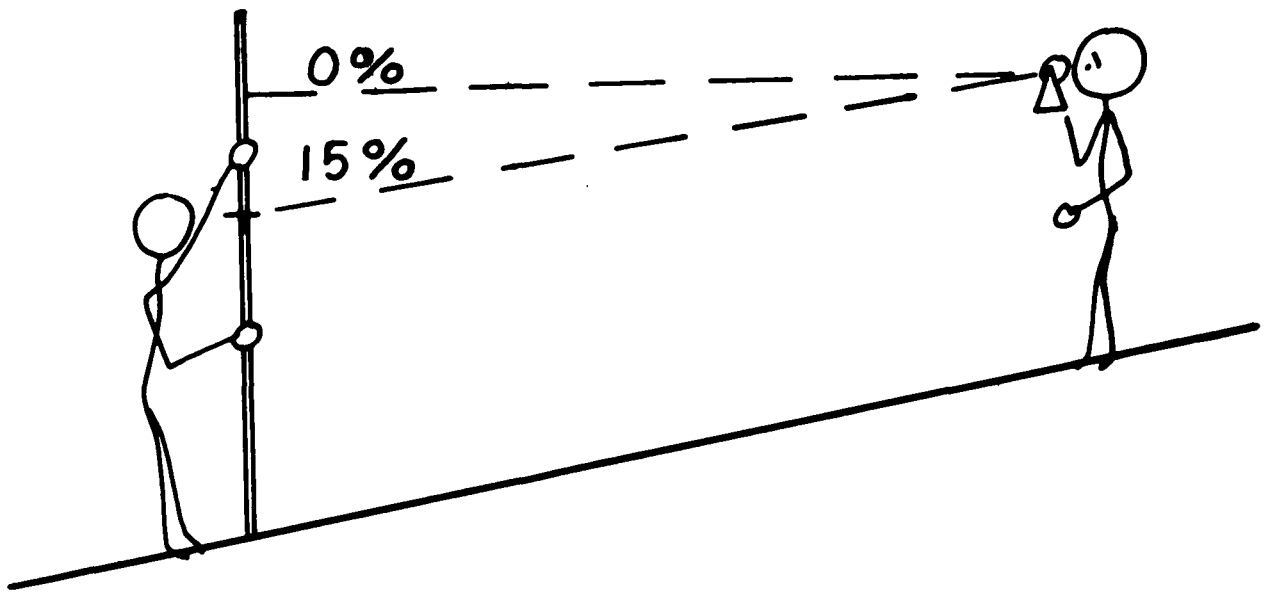

Measuring vertical intervals of previous terraces

For example the V.I. is 2.7 m to be measured with the clinometer. You can use your eye height for the first 175 cm:

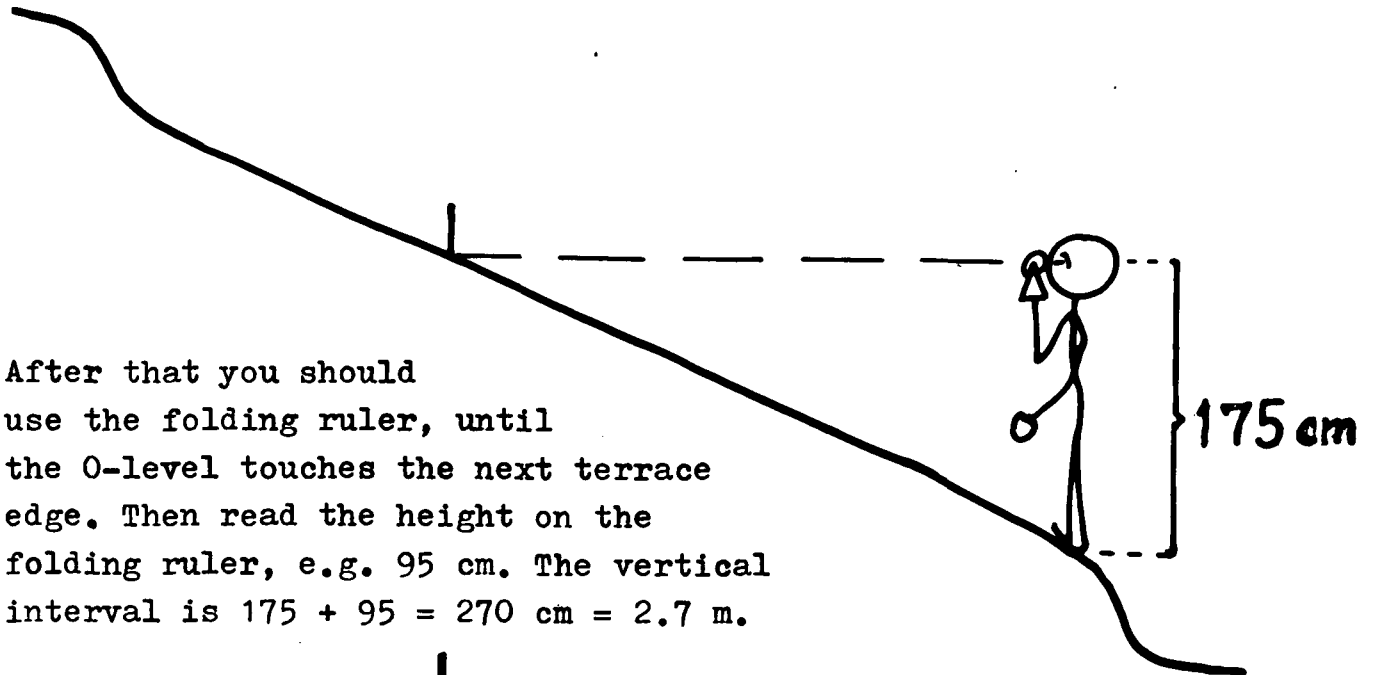

After that you should use the folding ruler, until the 0-level touches the next terrace edge. Then read the height on the folding ruler, e.g. 95 cm. The vertical interval is  $175 + 95 = 270$  cm = 2.7 m.

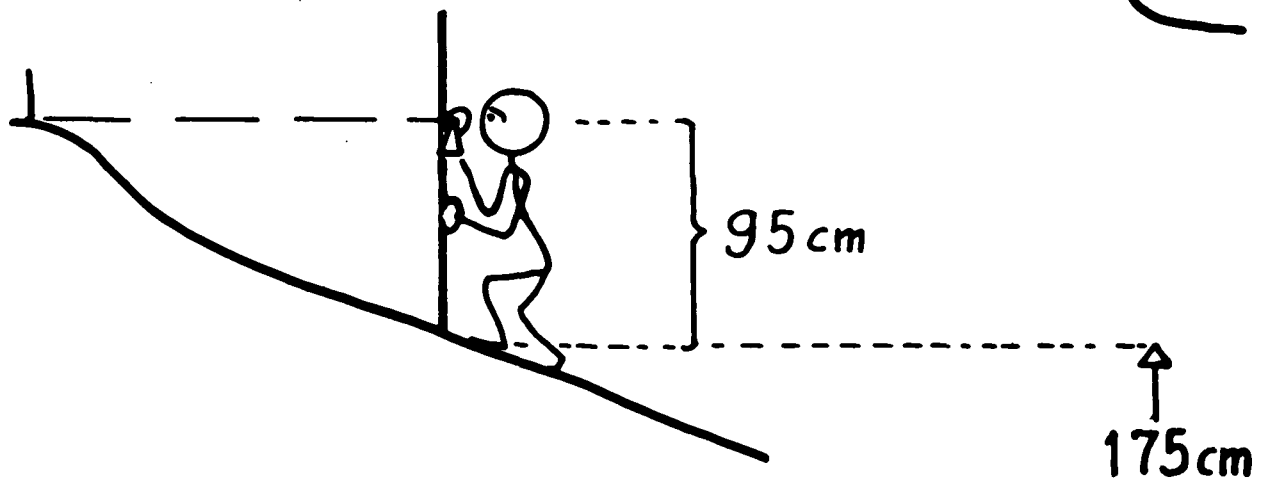

Another example:

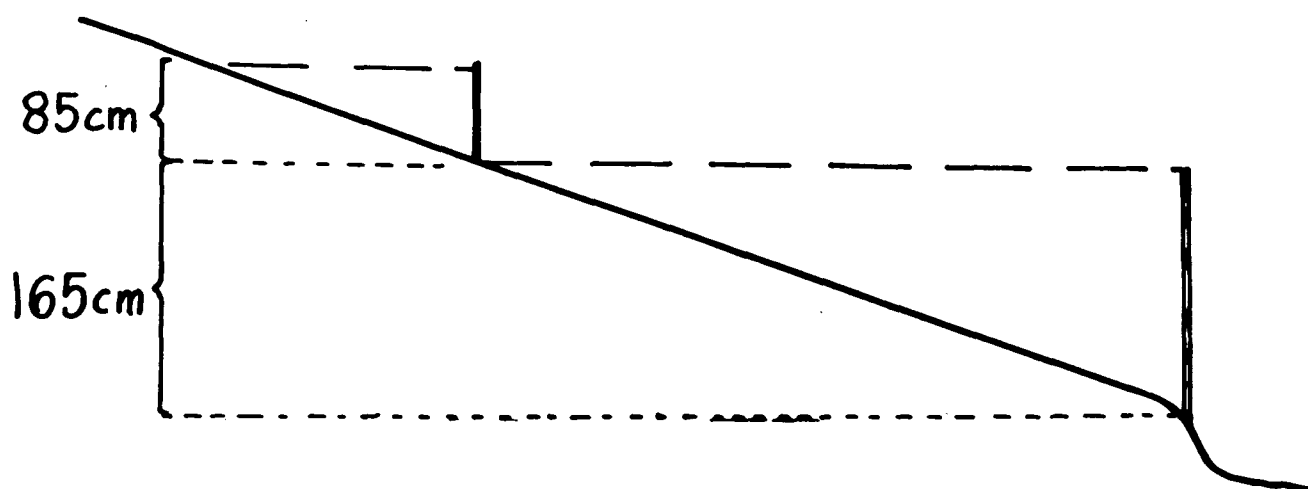

The difference in height is  $165 + 85 = 250 \text{ cm} = 2.5 \text{ m}$ .

Setting out vertical intervals

This is done in the same way as described above. The clinometer is especially good for setting out constant intervals of 1.5 - 1.8 m (= your eye height).

Setting out the gradient of terraces (or cutoff drains)

A slope of 0.5 % is a rise or fall in level of 5 cm in 10 m (5 cm to 1,000 cm =  $0.5:100 = 0.5 \%$ ).

You should mark a length of 10 m on the ground, and after that train yourself and your helper to walk this distance in 10 steps.

If you set out a terrace you should mark your eye height on the stick (staff), and put another mark below or above your eye height mark.

Thus your helper has to walk 10 m along the contour and there move the stick up and down the slope, until your 0-level in the instrument hits the lower mark on the stick. Then the stick stands 5 cm higher than you and 10 m away from you:

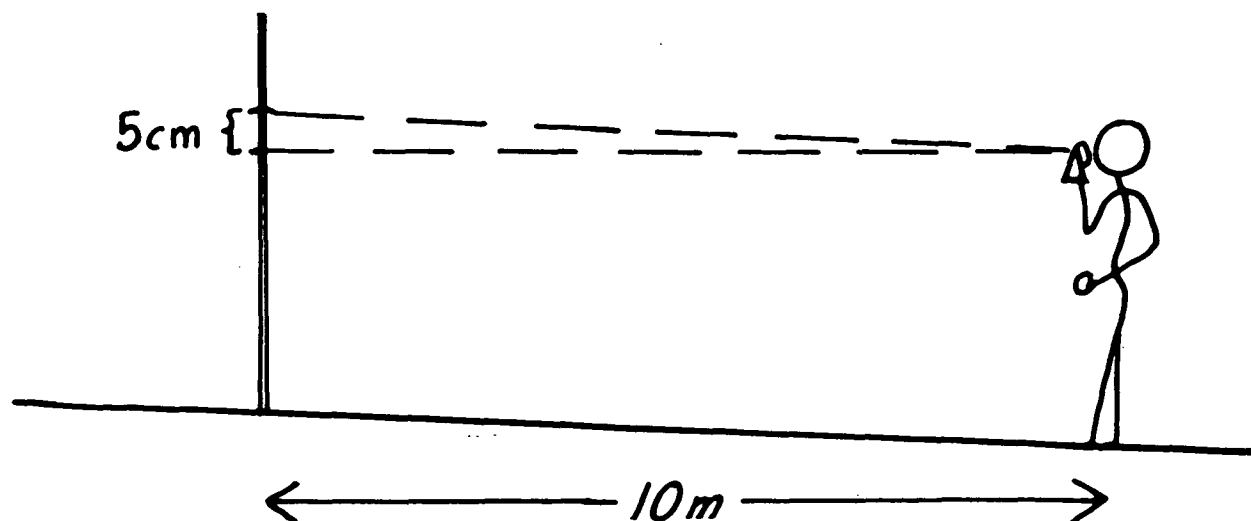

Alternatively, you need not make the lower mark, but just read 0.5 % above the 0-level:

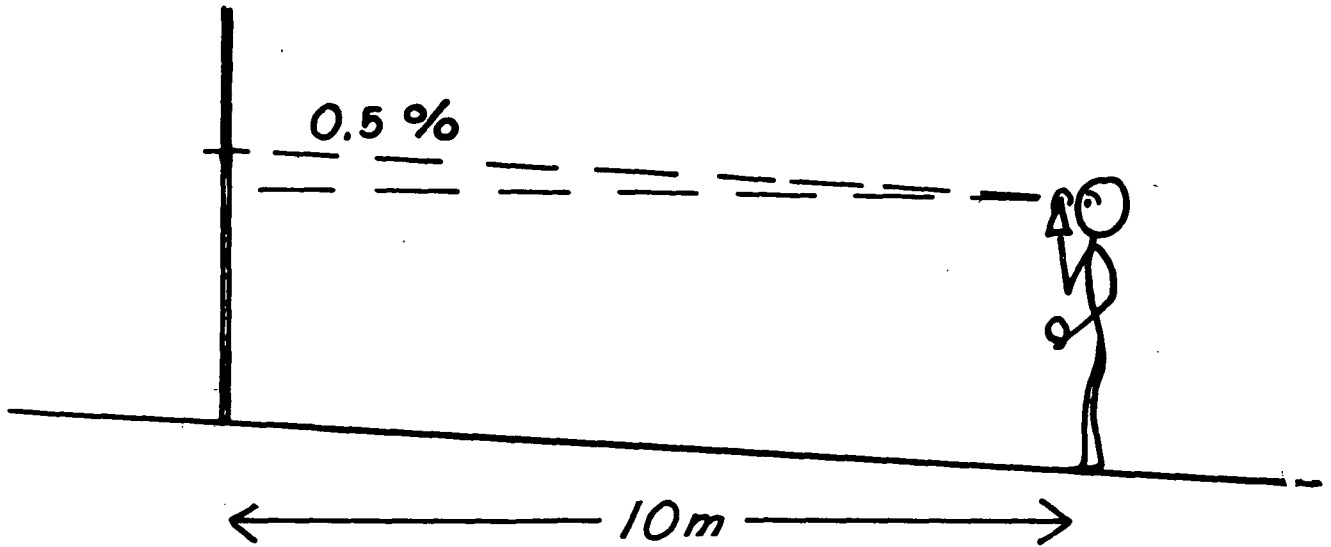

Some examples of different lengths and heights:

Length

10 m Every cm in height = 0.1 %, e.g. 2.5 cm = 0.25 %  
5 cm = 0.5 %  
10 cm = 1 %

25 m Every 2.5 cm in height = 0.1 %, e.g. 6.25 cm = 0.25 %  
12.5 cm = 0.5 %  
25 cm = 1 %

Measuring previous gradients

You do this in the same way as measuring the slope. If you are out in the field, you do not need a stick, but you can use another person for checking the gradient of for example a cutoff drain:

- 1) Let him walk 10 m away from you.
- 2) If he has the same eye height as you, you should find where the 0-level of the instrument hits the person, e.g. if it hits his face 8 cm below his eyes, the person will be on a piece of ground 8 cm higher than you. The grade is 0.8 % (8 cm to 1,000 cm = 0.8 : 100):

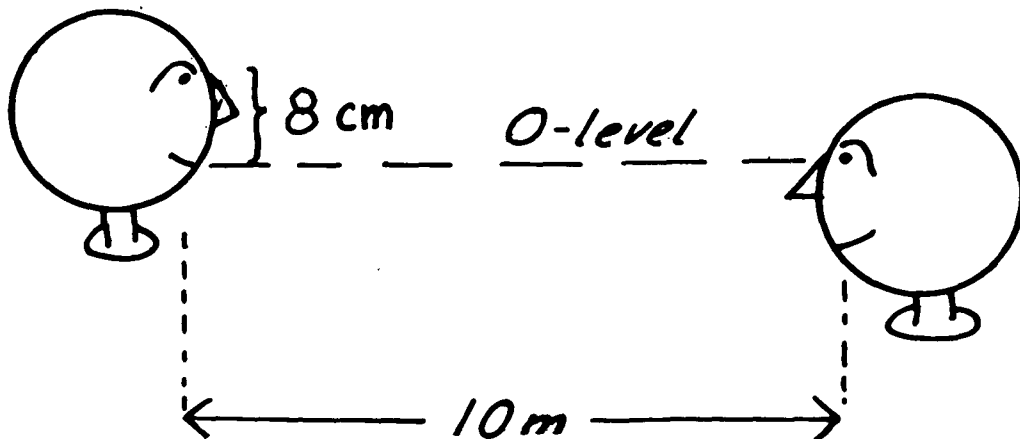

Practicals

1. Measure the percentage slope up and down the slope.
2. Measure the V.I., the H.I. and the gradient of existing terraces.
3. Lay out terraces using a constant V.I. of your eye height.
4. Set out the V.I. of the terraces on the slope of practical No. 1.
5. Lay out terraces graded to 0.5 % (using a 5 cm mark on a stick or a staff), and repeat this practical using the scale of the clinometer.

COMPARISON

	Price in shs 1979	Number of persons needed for operating the instrument
Line level spirit level, stick and strings	64	3
Quickset level with tripod and levelling staff	5,700	2
Hand level (clinometer) with folding ruler	817	2 - 1

The line level is the standard instrument, which should usually be used.

The quickset level is more accurate than the other two instruments, especially for the layout of cutoff drains.

The hand level is particularly suitable for the rapid checking of percentage slopes, intervals and gradients.

The technical assistants have been asked during the 1978 training courses which instrument they preferred for layout work. The result was as follows:

Line level	48 %
Quickset level	15 %
Hand level	19 %
Dont know	18 %

During the training courses the time needed for laying out 100 m of terrace has been:

Line level	14 - 30 min. (average 26 min.)
Quickset level	10 - 19 min. (average 15 min.)
Hand level	7 - 15 min. (average 11 min.)

XI LITERATURE ON SOIL CONSERVATION

Agricultural Gazette of New South Wales, October 1975: Kikuyu grass - a research report, pp. 2 - 24.

Ahn, P.M.: West African Soils. - Oxford University Press, 1970.

A scientific presentation mostly concerning soil chemistry and fertilizers.

Beckley, V. A.: Soil erosion. - Department of Agriculture, Bull. No. 1, Nairobi 1935.

Experience from Kenya 40 years ago.

Bene, J.G., Beall, H.W. and Cote, A.: Trees, food and people - land management in the tropics. - International Development Research Centre, Report of the project for identification of tropical forestry research priorities, December 1976.

Bisset, W.J. and Graham, T.G.: Creeping blue grass finds favour, Queensland Agricultural Journal, May-June 1978.

Bogdan, A.V. and Pratt, D. J.: Reseeding denuded pastoral land in Kenya. - Ministry of Agriculture, Republic of Kenya, Nairobi 1967.

This excellent publication is of value to those who are interested in rehabilitating pastoral areas.

Clayton, E.S.: Control of soil erosion. - New South Wales Department of Agriculture, Sydney 1935.

Clayton, E.S.: Gully erosion. A serious menace to farming and grazing land. - New South Wales Department of Agriculture, Sydney 1936.

Comary, Y. and Masson, J.: Etude de conservation des eaux et du sol au Centre de recherches du génie rural de Tunisie. - Cahiers O.R.S.T.O.M., Pedologie, Vol. II, No. 3, 1946.

This is a scientific application of Wischmeier's soil loss equation in relation to conditions in Tunisia.

Cruse, R.M. and Larson, W.E. : Effect of soil shear strength on soil detachment due to raindrop impact. + Soil Science Journal, Vol. 31, No. 4, Los Angeles 1977.

Department of Agriculture, Kenya Colony: A review of the position in regard to soil conservation in Tanganyika Territory in 1938. - Stencil report 11.5.1939.

Department of Agriculture, Kenya Colony: The evils of soil erosion and ways of preserving the land. - Government Printer, Nairobi.

Most of the text is still valid to-day. The text and many of the illustrations are well suited for reading by farmers.

Douglas, J.S. and de J. Hart, R.A.: Forest farming towards a solution to problems of world hunger and conservation. - Watkins, London 1976.



- D'Souza, V.P.C. and Morgan, R.P.C.: A laboratory study of the effect of slope steepness and curvature on soil erosion. - Journal of Agricultural Engineering, Vol. 21, 1976.
- Eden, T.: Elements of typical soil science. - Macmillan, London etc, 1973.
- FAO, Agricultural Studies No 4: Soil conservation, an international study. - Washington 1948.  
Soil erosion and soil conservation in broad outline in the U.S.A. South America and China.
- FAO, Agricultural Development Paper No. 81: Soil erosion by water. Some measures for its control on cultivated lands. - Rome 1965.  
The last chapters deal with the soil loss prediction equation (not very applicable to Kenya) and with a method for the design of cutoff drains.
- FAO: The soil - conserving the soil - improving the soil. - Better Farming Series No. 10, Rome 1970.  
Written for the African environment and suitable for teaching soil conservation in schools and during barazas. However, in the examples of rotational land-use strip cropping should be regarded.
- Fournier, F.: La recherche en érosion et conservation des sols dans le continent africain. - Sols Africains, Vol. VII, No. 1, 1967.  
Experience from Africa during 15 years, and modern points of view. Also translated into English.
- Gota, P.R. and Spooner, B.C.: Loan application, Soil Conservation Service, Equipment Phase II, March 1976. - Ministry of Agriculture, Republic of Kenya.
- Goujon, P.: Conservation des sols en Afrique et à Madagascar. - Bois et Forêts des Tropiques, No. 118, March-April 1968.
- Graham, R.M.: The planting of fuel and timber reserves on farms. - The East African Standard, September 4, 1942.
- Grandy, F.: Conservation of water for storage underground. - E.A. Agricultural Journal, Jan. 1946.
- Gwynne, M.D. and Pratt, D.J. et al. : Rangeland management and ecology in East Africa. - Hodder and Stoughton, London 1977.
- Hadley, R.F. : Evaluation of land-use and land-treatment practices in semi-arid western United States. - Phil. Trans. R. Soc. London, B. 278, p. 543-554, 1977.
- Hall, J. M.: A handbook on basic conservation and land use principles. - Extension Aids Branch, Department of Agriculture, Zomba, Malawi 1967.  
Simple and very good.

Haw, R. G.: The conservation of natural resources. - William Clowes and Sons Ltd, London and Beccles, 1959.

Experience from Rhodesia, but now rather dated in parts.

Henderson Research Station, Federal Department of Conservation  
Extension: Erosion Research No. 9-5039. - Mazoe, Southern Rhodesia, December 1956.

Herzath, V. and Erosi, B. : Determination of natural slope category limits by function identity of erosional intensity. - Institute for Hydraulic Planning, Budapest.

Hudson, N.W.: Results of erosion research in southern Rhodesia. - Advisory leaflet No. 13, Federal Department of Conservation and Extension, Salisbury, July 1959.

Hudson, N.: Soil conservation. - London 1971.

An excellent and modern text-book concentrating on erosion and soil conservation in developing countries, especially South Africa. The book can be recommended not only to agricultural engineers but to students of all applied sciences, which have a bearing on soil conservation.

Huntingford, R. L.: Contour cultivation for beginners or Terrace maintenance without tears. - Colony and Protectorate of Kenya, 1955.

Good illustrations of how to make terraces with a plough.

Jacks, G. V. and Whyte, R. O.: The rape of the earth. - Faber and Faber Ltd, 24 Russel Square, London.

Jones, M.J. and Wild, A. : Soils of the West Africa savannah. - Commonwealth Bureau of Soils, Technical Communication No. 55, Harpenden 1975.

Dealing with the maintenance and improvement of soils, and in connection to this the book has interesting chapters on soil conservation.

Kenya Arbor Society: Some notes on soil and water conservation. - Naivasha 1940.

Konke, H. and Bertrand, A. R.: Soil conservation. - Mac Graw Hill Book Company, New York-Toronto-London 1959.

This is an easily read text-book, concentrating on the conditions in the U.S.A.

Kowal, J.M. and Kassam, A.H.: Energy load and instantaneous intensity of rainstorms at Samaru, Northern Nigeria. - Tropical Agriculture, Vol. 53, Guildford 1976.

Trials and analyses of rainfall parameters and a mathematical analysis of the magnitude and seasonal distribution of the energy load of rainstorms on a tropical savannah.

Layzell, D.: Construction and use of the line level. - Soil Conservation Service of the Department of Agriculture, Republic of Kenya, Nakuru 1968 (stencil).

- Maher, C.:** Soil erosion and land utilization in the Embu Reserve. - Colony and Protectorate of Kenya, April 1938 (stencil).
- Maher, C.:** Notes on soil erosion and land utilization in Nyanza Province. - Colony and Protectorate of Kenya, July 1938 (stencil).
- Maher, C.:** The use of level contour banks and live or dead wash stops in erosion control. - E.A. Agricultural Journal, November 1939.
- Maher, C.:** Hill culture. - The East African Journal, July 1939.  
This paper includes trials on different tree crops.
- Maher, C.:** Protection of stream banks. - The East African Standard July 17, 1942.
- Maher, C.:** A short visit to Uganda to study soil conservation. - Stencil report to Department of Agriculture, Kenya, 8.6.1945.
- Maher, C.:** Soil and water conservation in the Punjab. - E.A. Agricultural Journal, October 1949.
- Maher, C.:** Bench terracing. - The Journal of International Agriculture World Crops, July-August 1973.  
Mainly dealing on the construction of stone terraces based on experience from different parts of the world.
- Maher, C. and Barnes, R. O.:** Notes for circular issue with U.S. Department of Agriculture farmers' Bull. No. 1789. - Colony and Protectorate of Kenya, 1939.
- Masefield, G. B.:** Narrow-base ridges for erosion control (Uganda). - E.A. Agricultural Journal, January 1942.  
Experience of 25 years ago from different parts of Africa and other parts of the world.
- von Maydell, H.-J.:** Tree and shrub species for agroforestry systems in the Sahelian zone of Africa. - Plant Research and Development, Institute for Scientific Co-operation, Vol.8, Tubingen 1978.
- Mortensen, E. and Bullard, E.T.:** Handbook of tropical and sub-tropical horticulture. - Division of Agriculture, US A.I.D. to Haiti, Washington 1966.
- Motheith, N.H.:** The role of surface roughness in runoff. - Soil Conservation Journal of New South Wales, Jan. 1974.

National report on the human environment in Kenya, prepared by the Working Committee for the United Nations Conference on the Human Environment, Nairobi June 1971.

This publication has figures (p. 74) on the total sediment load of some rivers, calculated as well as erosion rate in kg/ha. (if calculated in tons/acre varying between 0.1 and 6.4).

Nyoro, G. : An evaluation of soil conservation in Nyeri District. - Report for postgraduate diploma at the University of Nairobi, September 1978.

Olson, T.C. and Wischmeier: Soil-erodibility evaluations for soils on the runoff and erosion stations. - Soil Society of America, Proceedings Vol. 27, Madison 1963.

Pereira, H. C. and Beckeley, V. R. S.: Grass establishment on eroded soil in semi-arid African reserve. - The Empire Journal of Experimental Agriculture, Volume XXI, Oxford and London 1953.

Pereira, H. C., Hosegood, P. H. and Dagg, M.: Effects on tied ridges, terraces and grass legs on a lateritic soil in Kenya. - Experimental Agriculture, Volume 3, Cambridge 1967.

One of the very few scientific investigations on soil erosion in East Africa.

Pereira, H.C. : Land use and water resources in temperate and tropical climates. - Cambridge 1973.

Porrit, N.H.: How to save our soil. - Cape Town 1948.

A booklet suitable for schools, especially considering South African conditions.

Poulsen, G.: The role of forestry in Tanzania. - Division of Forestry, University of Dar es salaam, June 1976 (stencil).

Poulsen, G.: Man and tree in tropical Africa. - International Development Research Centre (Box 8500, Ottawa, Ontario, Canada), 1978.

There are three essays on trees as "nutrient pumps", as fuel and in the shifting cultivation. Of course most attention is given to more arid areas.

Pudden, H.H.C.: Exotic forest trees in the Kenya Highlands. - Colony and Protectorate of Kenya, 7th British Commonwealth Forestry in Australia, Nairobi 1957.

Purvis, J. T.: Wasted rainfall in relation to crop production. - E.A. Agricultural Journal, October 1945.

Rickey, C. B., Jacobson, P. and Hall, C. W.: Agricultural Engineer's Handbook. - Mac Graw Hill Book Company, New York-Toronto-London 1961.

A handbook rather difficult for beginners.

Schwab, G. O., Frevert, R. K., Barnes, K. K. and Edminster, R. W.: Elementary soil and water engineering. - John Wiley & Sons, New York-London-Sydney-Toronto 1971.

There are short but good chapters on soil erosion, waterways and terracing.

Schwab, G. O., Frevert, R. K., Edminster, T. W. and Barnes, K. K.: Soil and water conservation engineering. - John Wiley & Sons, New York-London-Sydney, 2nd edition, 1966.

Smith, D.D. and Wischmeier, W.H.: Rainfall erosion. - Advances in Agronomy, Vol. 14, New York 1962.

This paper summarizes previous publications regarding rainfall energy and the soil loss equation established by Wischmeier.

Tempany, H. A.: The practice of soil conservation in the British Colonial Empire. - Commonwealth Bureau of Soil Science, Harpenden 1949.

Thomas, D. B.: Air photo analysis of trends in soil erosion and use in part of Machakos District, Kenya. - Xerox copy of a thesis submitted to the University of Reading, 1974.

Evidence is given to show gully erosion became a serious problem between 1910 and 1948. After that the gullies have increased not so much in length but in width.

Thomas, D.B. : Some observations on soil conservation in Machakos District, Kenya, with special reference to terracing. - Stenciled paper presented at a Soil Conservation Workshop, University of Nairobi 21-23.9.1977.

Tiedemann, A.R. and Klemmedson, J.O.: Effect of Mesquite trees on vegetation and soils in the desert grassland. - Journal of Range Management 30 (5), September 1977.

U.S. Department of Agriculture, Soil Conservation Service, Agriculture Handbook No. 61: A manual on conservation of soil and water. - U.S. Government Printing Office, Washington 25, D.C.

Walter, W.K.: Strip cropping for soil conservation. - Farmers Bull. No. 176, U.S. Department of Agriculture, Washington 1937.

Watson, T.Y.: The value and cultivation of fodder grass. - The East African Standard, August 21, 1942.

Weber, Fred R.: Reforestation in arid lands. - U.S. Volunteers in Technical assistance, Vita Publications, Manual Series No. 37 E, Mt. Rainier, MD, USA.

Webster, C. C.: Land utilization and soil fertility maintenance in Kenya. - Proceed. 2nd Inter-African Soils Conference, Leopoldville 9 - 14 August 1954.

Webster, C. C. and Wilson, P. N.: Agriculture in the tropics. - Spottiswoode, Ballantyre and Co Ltd, London and Colchester 1966.

This excellent textbook has a short but good chapter on soil conservation.

Verbugt, W.H.: Pasture handbook, Kenya Seed Company Ltd, January 1979.

VIAK EA LTD : Migori-Kihancha regional master plan. Water and land utilisation, Nairobi 1975.

Wischmeier, W.H.: Cropping-management factor evaluations for a universal soil-loss equation. - Soil Science Society of America, Proceedings Vol. 24, Madison 1960.

#### Addenda

Graham, R.M.: Tree planting on farms. - Forest Department, Republic of Kenya 1974.

Greenham, D.J. and Lal, R.: Soil conservation and management in the humid tropics, John Wiley & Sons, Chichester etc 1979.

## ALPHABETIC SUBJECT LIST

### A

Absorption terrace, 97  
Acacia albida 116, 121, Appendix 3 p 2  
Adjudication of land, 138  
Adjudication maps, 157  
Aerial photographs, 157  
African Foxtail, 111, Appendix 2 p 2  
Agriculture Act, 123, 134-135, 139  
Agro-forestry, 49, 114, 115  
Algaroba, 115, 116, Appendix 3 p 2  
Annual rainfalls, 141, 144  
Annual soil loss, 22  
Apple Ring Acacia,  
see Acacia albida  
Apples, 122  
Approach to farmers, 147  
Arnoldus, 30  
Artificial waterway, 70, 191  
    cross-section, 70-73  
    design, 72  
    depth, 73  
    grass cover, 73-74  
    illustration, 51-51, 72  
    lock and step drain, 74  
    need, 70  
    siting, 70, 73  
    subsidies, 53  
    width, 71-73  
Avocados, 122  
Azadirachta, see Neem tree

### B

Badlands, 109  
Bahia Grass, 97, Appendix 2 p 5  
Bamburi, 116  
Bana Grass, 9, 40, 96  
Bananas, 45-46, 118-119, 121, 122,  
    127, 142  
Baringo District, 111  
Basin listing, 44  
Bauhinia, 121a  
Beckley, 74

Bench terrace, 4, 33, 48, 51,  
    75-77, 86-92, 93, 95  
Bermuda Grass, 97  
Biological measures, 36  
Blind terrace, 97  
Bogdan and Pratt, 110  
Botriochloa insculpta, Appendix 2 p  
Brachiaria decumbens, 97  
Broad - base terrace, 75-77  
Buffel Grass, 111, Appendix 2 p 2  
Buffer strip cropping, 46  
Buffer strips, 30a, 46  
Building poles, 122  
Burning, 110, 145  
Bush hedges, 49  
Bush rye, 111, Appendix 2 p 3

### C

Calcium, 39  
Callitris robusta, 19  
Cameroon, 121a  
Cassava, 30  
Cassia, 121, 121a, 122, Appendix 3 p 3  
Cashew nut, 121, 122  
Casuarina, 19, 121, 121a, 122  
Catchment area, 57  
Cedar, see Juniperus  
C- factor, 27-30a  
Cenchrus ciliaris, 111, Appendix 2 p 2  
Channel factor, 61  
Channel terrace, 30a, 75-77  
Charreau and Vidal, 121  
Check dams, 9-10a, Appendix 1  
Chloris gayana, 111, Appendix 2 p 2  
Christoi, 43  
Citrus, 116 121  
Clayton, 168,  
Classification of land 138, 193  
Climate, 144  
Climometer, 177, 183  
Clods, 38-38a  
Closing from grazing, 110

## C-Continued

- Coconuts, 121
- Coffee, 30, 140
- Cohesion of soil, 5, 25
- Colin Maher, 84
- Coleus barbatus, 49
- Coloured Guinea Grass, 111, Appendix 2 p 4
- Companion crops, 30b, 40, 43-44
- Conocarpus, 19, 121a 122
- Conservation terrace, 47
- Constant vertical interval, 84-88
- Contour belts, 45-45a
- Contour farming, 7, 30a, 43-44
- Contour ploughing, 43-44
- Contour strip cropping, 7, 18
- Converse terrace, 78
- Conversion tables  
degrees and percentages slope, 136  
metric system, Appendix 4
- Cook's method, 57
- Costs, 66, 99-104
- Cotton, 30
- Counter pressure, 16
- Cover crops, 30
- Creeping Bluegrass, Appendix 2 p7
- Creeping Signal Grass, 97
- Cropping factor, 27-30
- Crop, 30, 40  
choice of crop, 40  
companion crops, 30b, 40  
crop stage periods, 27  
early planting, 40  
rotation, 7, 42-43
- Crotolaria, 49
- Croton megalocarpus, 121a
- Crumb structure, 42
- Cultivation  
steep slopes, 170  
very steep slopes, 140, 142
- Cultural measures, 38
- Cupressus, 19, 121, 122
- Cusecs, 60
- Cushion Lovegrass, 111
- Custard Apple, 122
- Cutoff drain, 50-69  
calculation and design, 54-63a, 65  
costs, 66  
cross-section, 53-62, 65  
depth, 54, 62  
digging, 65, 68  
discharge, 53  
embankment, 54-55  
example, 63  
gradient, 64  
grass, 143  
grazing control, 112-113  
illustration, 51, 55  
grazing control, 64, 112-113  
illustration, 51  
layout, 174, 181  
length, 65  
maintenance, 66-69  
need, 52-53  
outlet point, 53  
questions, 63b, 69a  
survey of site, 52-53  
trees, 64  
vegetational cover, 64, 118-121  
width, 54-55, 62
- Cutting of forest, 12
- Cynodon dactylon, 111, Appendix 2 p 2
- D
- Dates, 122
- Depth of soil, 139
- Destocking, 110, 112
- Developed bench terrace, 48, 77,  
89, 92, 93
- Digging costs, 66, 99-104, 196
- District Development Committee, 106



Subject list D - G

D - Continued

Diversion ditch, 9, 52, 69  
bush/grassland, 52  
cultivated land, 52  
gully control, 9  
illustration, 51  
tea, 69  
Dol Dol, 112  
Durbach's method, 61

E

Early planting, 40  
Earth flow, 14  
Ecozones, 144  
Energy of raindrops, 4, 22, 24  
Enteropogon machrostachyus, 111, Appendix  
Eragrostis caespitosa, 111 2 p 3  
    cilianensis, 111, Appendix 2 p 3  
    superba, 111, Appendix 2 p 3  
Erodibility, 5, 17, 25, 81  
Eros Data Center, 160  
Erosion, 36, 185  
    causes, 36  
    different crops, 40  
    geological, 36  
    grazing land, 109  
    gully erosion, 8  
    natural, 36  
    nutrients, 95  
    pavement natural, 3  
        artificial, 71  
    rain drop erosion, 3, 41  
    reduction, 38, 117  
    rill erosion, 6  
    river erosion, 11, 130-133  
    slope, 6, 124-129  
    soil loss, 21-21  
    solifluction, 14  
    splash erosion, 3  
    stream erosion, 5

watercourses, 130-133, 142, 150  
velocity of water, 5, 13  
    wind, 17  
wind erosion, 17

Erosion pavement, 3  
Erosion zone, 130, 142, 150  
Erosive rain, 4  
Erosivity, 24  
Eucalyptus 14, 118, 121-122, 142-143  
Excavated bench terrace, 75-77,  
    88b, 89-90

F

Fallow, 27, 109  
Fanya Juu terrace, 75, 92-95, 98  
Farm management, 38, 185  
Farm planning, 137  
Farmers, 147  
Fertility, 39  
Fertilizers, 39, 42  
Ficus, 121a  
Finger Euphorbia, 49  
Flood zone, see Erosion zone  
Flooding, 12  
Fodder trees, 112, 115, 121, 122  
Forest, 30, 30a  
Formulas for intervals, 81, 87-88  
Fournier, 38a  
Fractions of soil, 5  
Fruit trees, 122, 142

G

Gabions, 13, Appendix 1 p 8-12  
Gitau Nyoro, 92  
Gmelina, 122  
Goats, 144  
Grade, see Gradient

## G - Continued

Gradient of cutoff drains, 64  
terraces, 97-98

Graham, 142

Grass  
cover, 30-30a, 95-98, 113, 140  
reseeding, 110  
perennial, 109-110  
seed rate, 111  
species, 96-97, 111, Appendix 2  
strips, 30a, 47-48, 95

Gravel, 25

Grazing control, 110, 113

Grazing land, 108, 143

Green manuring, 42

Grevillea, 19, 121

Grey Lovegrass, 111, Appendix 2 p 3

Groundnuts, 30

Ground water, 14-16

Guatemala Grass, 96

Guava, 121-122

Guinea Grass, 97, 111

Guiscafre, 121a

Gully control, 9-10a, 113, Appendix 1

Gully erosion, 8, 109

Gum tree, see Eucalyptus

## H

Hall, 71

Handlevel, see Clinometer

Harrowing, 110

Hawaii, 4

H.I., see Horizontal interval

High - water zone, 130

Hillside ditch, 78, 92a, 94

Holtan, 41

Hook Grass, 111, Appendix 2 p 4

Horizontal interval, 81-81b, 83-87

Hudson, 39, 60

Human influence, 21

Humus, 121

Hydrological conditions, 12

Hypparhenia rufa, Appendix 2 p 4

## I

Idle land, 30

Infiltration, 6, 25, 41, 46, 57, 95, 109

Instructions to assistants, 146

Instruments, 161

Intensity of rain, 4, 22-24

International Development  
Research Centre, 115

Iron oxide, 25

Ironwood, 122

Ivory Coast, 95

## J

Jacaranda, 121a

Juniperus, 122, 142

## K

Kandani, 143

Kanga, 116

Kangema, 16

Kericho District, 69

Key terrace, 78

K-factor, 25

Kikuyu Grass, 73, Appendix 2 p 5

Kirinyaga District, 69

Kitui District, 92, 111

Kikuyu Grass, 73, Appendix 2 p 5

Kowal, 44

## L

Laikipia District, 112

Lal, 38a

Land slide, 15-16

Latipes senegalensis, 111, Appendix,  
Lay out, 167, 174, 193 2 p 4

Legislation, 123

Legume, 46

Length - Slope factor, 25-26a

Leucaena, see Lucena

Subject list L - O

L - Continued

Level terrace, 97  
Limes, 122  
Line level, 162, 183  
Listing, 44  
Literature, 184  
Livestock unit, 112, 144, 151  
Lock and step drain, 74  
Local characteristics, 57  
Loquats, 122  
IS - factor, 25-26a  
Lucena, 116, 121-122, Appendix 3 p 2

M

Macadamia, 116, 122  
Machakos District, 92, 111, 115  
Maintenance form, 66-69  
Maize, 30, 140  
Makarikari Grass, 97, 111  
Malawi, 54, 71  
Mangoes, 116, 121-122  
Mangum terrace, 76  
Manure, 42  
Maps, 153  
Marikari Grass, 92, 97  
Masai Lovegrass, 111, Appendix 2 p 3  
Mass movement, 15  
Matuga, 42  
Maximum terrace width, 84, 87  
Maximum velocity, 5, 61  
Maya-Indians, 116  
Mean annual rainfall, 141  
Measuring tape, 169  
Mechanized soil conservation, 101, 199  
Microclimate, 121  
Millet, 30  
Minimum tillage, 38a  
Modified bench terrace, 75-76, 87  
91-92, 119-120  
Moore, 95

Motor Grader, 101-104, 198  
Mueri, 142  
Mulberry, 122  
Mulching, 4, 30a, 41-42, 69  
Murang'a District, 143  
Murrum, 25  
Natural vegetation, 144, 150

N

NASA, 160  
Nandi Flame Tree, 121a  
Nandi Setaria, 97  
Napier Grass, 9, 96, 142, Appendix 2 p 6  
Narok District, 47  
Narrow - base terrace, 75-77  
Natural vegetation, 144, 150  
Neem tree, 121, 121a, 122,  
Appendix 3 p 3  
Negative geotropism, 14  
Ngelani, 115  
Nichols terrace, 76  
Nigeria, 38a, 44  
Nitrogen fixing, 118  
Nutrient pump, 121  
Nyeri District, 92

O

Oats, 69  
Olive, 142  
Oranges, 122, 142  
Organic matter, 39  
Overgrazing, 109, 113  
Overstocking, 109

Subject list P - S

P

P - factor, 30b  
Palms, 30  
Panicum, 97, 111, Appendix 2 p 5  
    coloratum, 97, 111, Appendix 2 p 4  
    maximum, 97, 111, Appendix 2 p 5  
Papaya, 122  
Paspalum notatum, 97, Appendix 2 p 5  
Pasture, 30, 41, 43, 112, 143  
Pasture furrow, 110  
Peaches, 115, 121-122  
Pears, 122  
Pennisetum clandestinum, 73, Appendix 2 p 5  
    purpureum, 96, Appendix 2 p 6  
Peppar Tree, 19, 121a 122  
Pereira, 118  
Perennial crop, 46  
Physical measures, 36  
Piece work payment, 99-100  
Pineapples, 46  
Pinus patula, 121  
Pitting, 44  
Ploughing  
    along contour, 30, 43  
    up and down, 30  
Plums, 122  
Podocarpus, 122, 142  
Policy, 105-107, 198  
Pomegranate, 122  
  
Potatoes, 44  
Potential zones, 144  
Poulsen, 115  
Practice factor, 30a  
Pratt, 144  
Previous rules, 124, 130  
Profile levelling, 176  
Prosopis, 116, 121-122, Appendix 3 p 3  
Protein content, 115

Q

Quickset level, 169, 183

R

R - factor, 22 - 24  
Rain, 24  
Rain gauge, 22,  
Raindrop erosion, 3-4  
Rainfall erosion index, 27  
Rainfall factor, 22-24  
Rainfall map, 141  
Rangeland, 30  
Reafforestation, 12, 117, 118  
Red Oat Grass, 111, Appendix 2 p 6  
Register index map, 157  
Rehabilitation of grazing land, 110  
Remote sensing, 160  
Retension terrace, 97  
Rhodes Grass, 97, 111, Appendix p 2  
Ridge terrace, 75-77  
Ridging, 30a, 43-44  
Rill erosion, 6  
Riser, 95-98  
River bank, 11-13, 118, 150, 196  
River control, 11-13, 118, 150,  
    Appendix 1  
River erosion, 11, 130-133, 150  
Rotation, 42-43  
Runoff, 12, 57

S

Satellite map, 160  
Savannah, 30  
Schinus molle, see Pepper Tree  
Scratch ploughing, 110  
Semi-arid area, 121-121a  
Senegal, 38-38a, 121

## Subject list S

### S-Continued

- Setaria, 97, Appendix 2 p 6
- She-Oak, 122
- Shear strength, 3,15
- Sheet erosion, 6
- Shelter belt, 18-19, 121a
- Sisal hedges, 46, 49
- Siting of cutoff drains, 52-53, 56
  - terraces, 78-80
- Slides, 15-16
- Slip surface, 15
- Slumping, 15
- Slope %, 6, 75, 84, 124-129, 136, 164, 173, 179
  - classification, 139
  - length, 6, 25
  - small slopes, 142
  - without terracing, 129
- Soil
  - aggregates, 39
  - characteristics, 139
  - classification, 5, 139
  - clods, 38
  - depth, 139
  - divalent ions, 39
  - erodibility, 5, 17, 25, 81
  - erosivity, 24
  - fertility, 39
  - fractions, 5
  - properties, 38
  - sealing, 37
- Soil conservation, 36
  - agreements, 149, 152
  - alternatives, 147
  - benefits, 199
  - biological measures, 37
  - buffer strip, 46
  - check dam, 7-10a
  - contour farming, 7
  - crumb structure, 42
  - cultural measures, 37
  - farmer, 147
  - force, 149
  - grass strips, 47-48
  - grazing land, 109-113
  - gully control, 8-10a, Appendix 1
  - layout, 167, 174
  - machines, 75
  - mechanized, 75, 101-104, 199
  - mulching, 4, 30a, 41-42, 69
  - physical measures, 37, 50
  - planning, 147
  - policy, 105-107
  - reasons, 147
  - rehabilitation of eroded land, 117-118
  - rill erosion, 7
  - river control, 11-13
  - semi-arid area, 121-121a
  - shelter belt, 18-19
  - slopes, 124-129
  - splash erosion, 4
  - stone terrace, 95-96, 142
  - strip cropping
    - water, 7, 30a, 45-45a
    - wind, 18
  - stubble mulch tillage, 17
  - trees, 150
  - very steep slopes, 140
  - water courses, 130-133, 150
- Soil erodibility factor, 25
- Soil loss, 21-22, 28
- Soil loss equation, 21
  - examples, 31-34
  - factors, 21-30
  - questions, 34
- Soil loss ratio, 27
- Solifluction, 14
- Sorghum, 30
- South Nyanza, 112
- Spacing of cutoff drains, 52-53
  - terraces, 81
  - trees, 117

## S - Continued

- Spirit level, 162, 183
- Splash erosion, 3
- Star Grass, 9, 111, Appendix 2 p 2
- Steep slope, 140
- Steepness, 25
- Step terrace, see Modified bench terrace
- Stereoscope, 158-159
- Stock unit, 25
- Stone terrace, 95-96, 142
- Storm drain, 52
- Stream erosion, 5
- Strip cropping, 7, 45, 30a  
width, 144  
wind erosion, 18
- Stubble mulch tillage, 17
- Sub-chief, 149
- Subsidies, 105-107, 198
- Sugar cane, 46, 127, 142
- gradient, 97-98
- grass cover, 95-98
- grass species, 96-97, Appendix 2
- hillside ditch, 78, 92a 94
- horizontal interval, 81-81b, 83-87
- infiltration, 95
- key terrace, 78
- layout, 167, 174, 181
- legal aspects, 124-129, 134-135
- length, 98
- level terrace, 97
- maintenance, 98-98
- maximum width, 84, 87
- modified bench terrace 75-76,  
87, 91-92, 119-120
- narrow-base, 75-77
- need, 75
- overtopping, 98
- pegging, 149
- retension terrace, 97
- ridge terrace, 75-77
- rules, 78
- siting, 78-80
- slope, 84
- spacing, 81
- stone terrace, 95-96
- top terrace, see Hillside ditch
- trash line, 46-47
- uphill ditch, see Hillside ditch
- types, 75-77, 187
- uphill ditch, 92, 94
- vegetative cover, 96-97
- vertical interval, 81-82, 85-88, 166
- Texture, 42
- Themeda triandra, 111, Appendix 2 p 6
- Tied ridges, 30a
- Timber production, 117, 122
- Tobacco, 30, 42, 44, 140, 142
- Top terrace, see Hillside ditch
- Topographic factor, 25
- Topographical map, 154

## T

- Tanzania, 49
- Tea, 42, 49, 69, 127, 142
- Telescope, 169
- Termites, 42, 121a
- Terracing, 7, 30a, 75, 186  
alternatives, 147-148  
bench terrace, 4, 33, 48, 51,  
75-77, 86-92, 93, 95  
broad base terrace, 75-77  
calculation of soil loss, 21  
channel terrace, 75-77  
constant vertical interval,  
84-88, 92-93  
converse, 78  
costs, 99-104  
development of bench terrace, 92, 93, 188  
excavated bench terrace, 75-77, 88b-90  
Fanya Juu terrace, 92-95, 98  
formulas, 81, 87-88  
graded terrace, 98

Subject list T - Z

Topography, 57

Topsoil

formation, 22

thickness, 36

Tractor, 44, 139

Training bank, 52

Transport in river, 11

Trash farming, 42

Trash line, 46-47

Trees, 49, 116, Appendix 3

benefits, 115-117, 121-121a, 150

cutoff drain, 118-121

farms, 115, 117

fodder trees, 121-122

food yield, 115-116

forest belt, 118

gully control, 9, 117-118, Appendix 1

improvement of soil, 117-118, 121-121a

ornamental, 121a

planting, 119-120

planting distance, 117

reclamation of land, 117-118

river bank, 12-13, 118

selection, 121a

semi-arid, 121-121a

shade trees, 121a

shelter belt, 18-19, 121a

species, 121a, 122, Appendix 3

terraces, 118-121

timber, 117, 122

wind break, 17-19, 121a

*Tripsacum laxum*, 96

U

Uphill ditch, see Hillside ditch

Upper limits for cultivation, 124-129

Upper Volta, 4, 43

V

Vegetation modification, 110

Vegetational strip, 30a, 46-47

Vegetative cover terraces, 96-97

Vertical interval, 81-82, 85-88, 165-166,  
173, 180-181

Very steep slope, 140

Vetiever Grass, 97

V.I., see Vertical interval

Voi, 111

W

Wanjerele, 16

Wash erosion, 6

Wash, stop, 46

Watercourse, 130-133, 142, 150

Waterfall erosion, 8

Wattle, 142

White propinac, 116

Wind break, 17-19, 121a-122

Wind drift, 17

Wind erosion, 17

Wind strip cropping, 18

Wischmeier,

equation, 21

cropping factor, 28

Y

Yatta Plateau, 111

Z

Zing terrace, 47

APPENDIX NO. 1

GULLY CONTROL

DESIGNS FOR GULLY CONTROL

	pages
1. Possible to divert the water from the gully by a diversion ditch	
2. Not possible to divert the water	
2.1 Head of gully	
2.1.1 Wooden materials	1
2.1.2 Stone materials	
2.1.2.1 Low head	2
2.1.2.2 High head	3
2.2 Floor of gully	
2.2.1 Wide and shallow (vegetative strips)	4
2.2.2 Narrow and steep (check dams)	5
2.2.2.1 Wooden materials	5-6
2.2.2.2 Stone materials (large stones)	7
2.2.2.3 Stone materials (small stones)	8-10
2.3 Side walls of gully	
2.3.1 Wooden materials	11-12
2.3.2 Gabions	12



Head of gully

"Waterfall erosion" of the water flow can be stopped through a protecting carpet of piled beds of straw and brushwood (see below) or stones (pages 2- 3).

Wooden material

Longitudinal section  
before measure

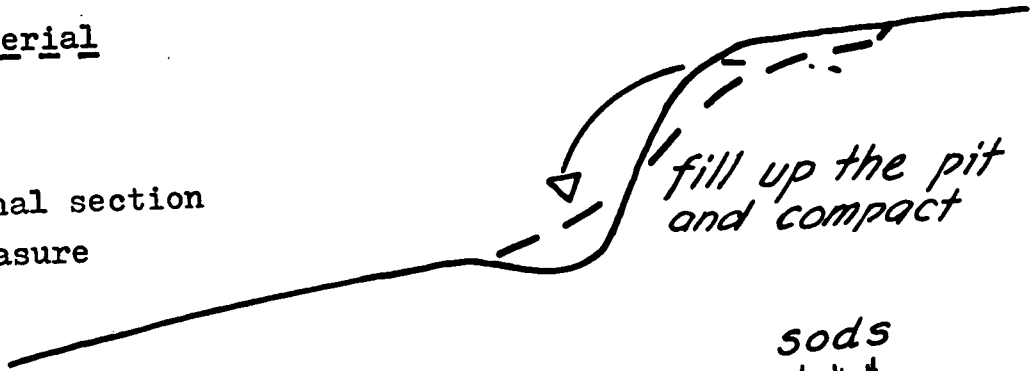

Longitudinal section  
after measure

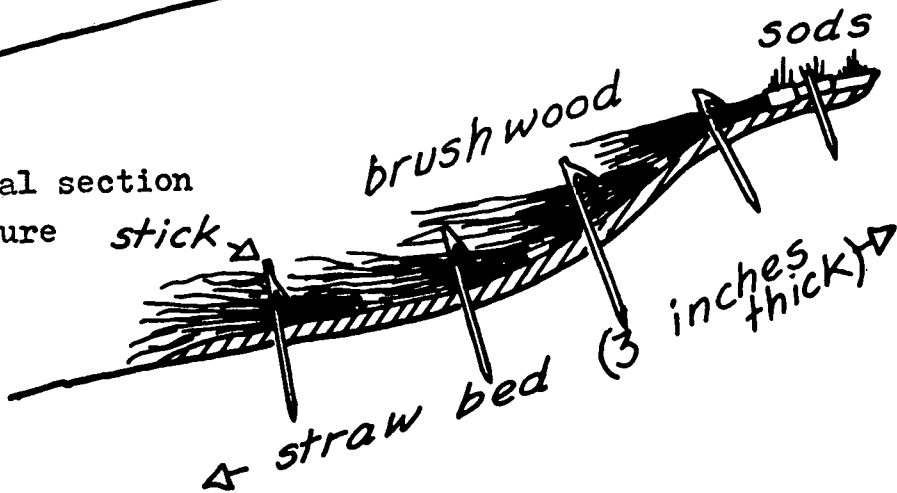

View from above

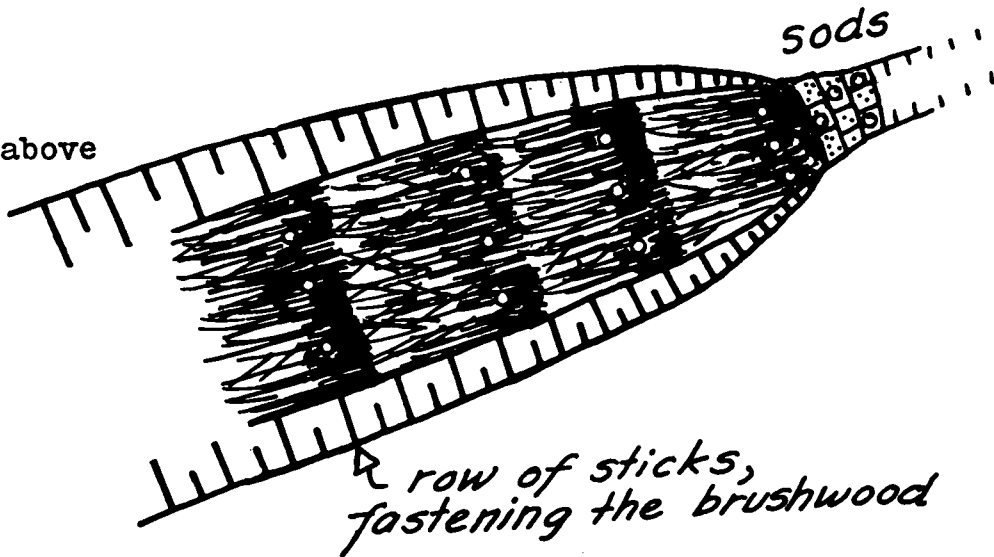

Cross-section

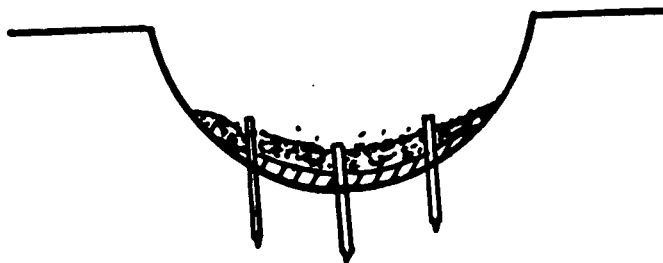

Stone material

Stone protection (figures below) is stronger than the wooden one, and can be especially strong by filling up in layers (figure on the next page). If only small stones are available, gabions can be used (i.e. prefabricated iron cages filled up with stones), see page 9.

A LOW HEAD OF A GULLY  
Longitudinal sections

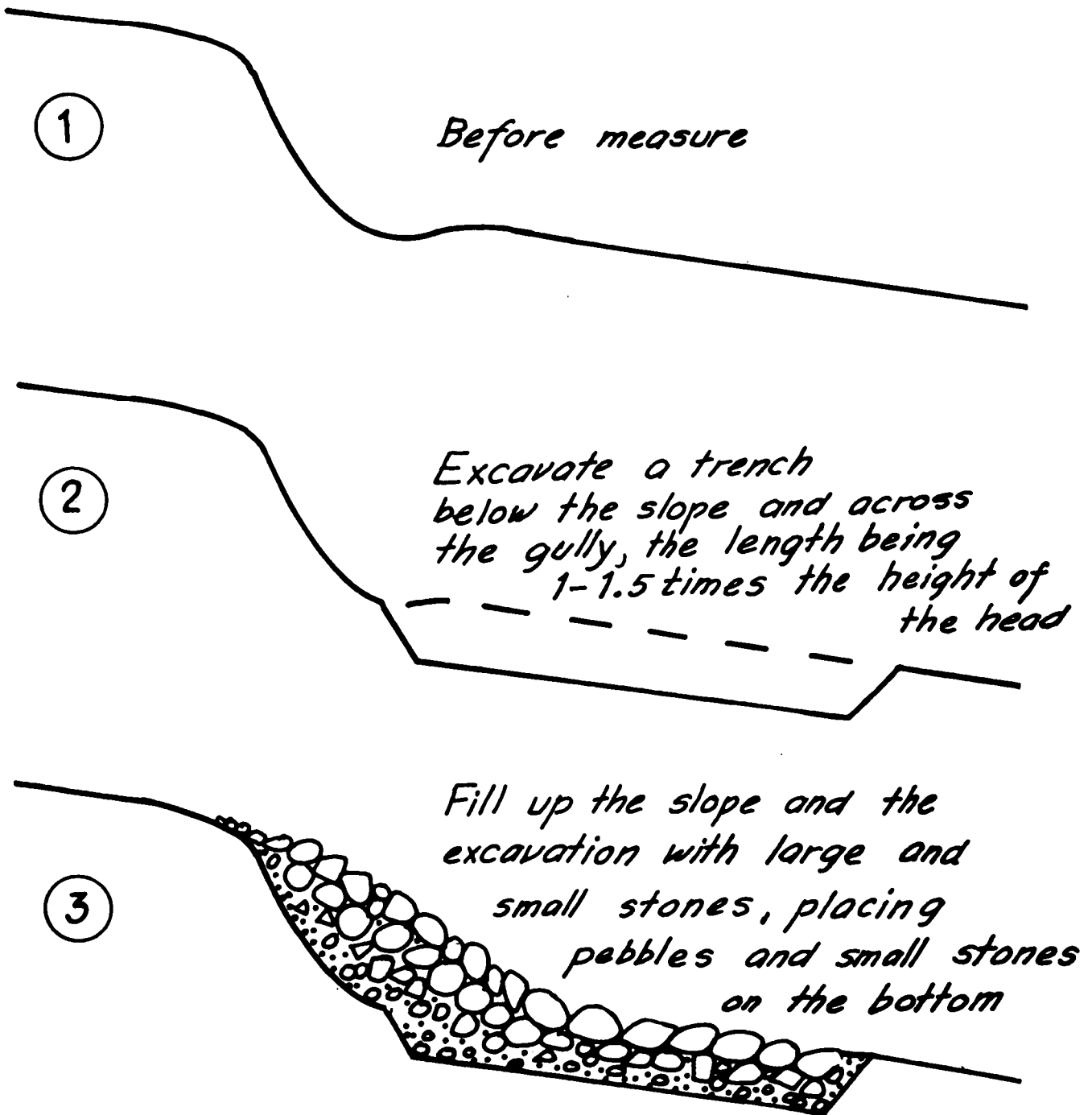

### A HIGH HEAD OF A GULLY

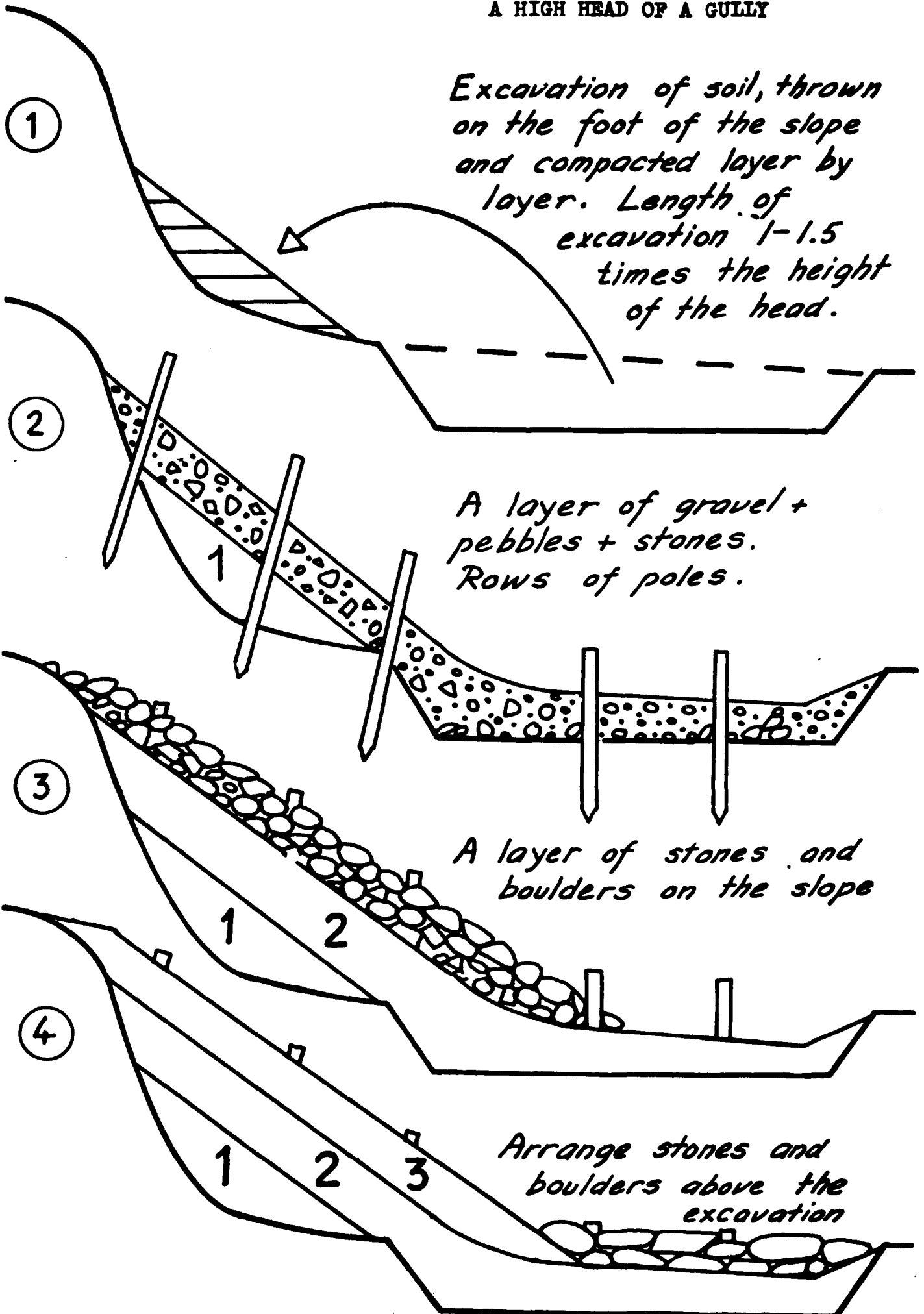

Floor of gully, wide and shallow

Erosion on the floor of a gully can often be stopped by strips of grass or turves (in arid areas sisal), placed at every 2nd, 4th or 6th metre.

Alternatively thresholds of stones can be arranged across the floor instead of vegetation. The stones should be put into an excavation (approximately 0.5 feet deep), so the upper parts of the stones are level with the floor of the gully.

It is also possible to combine the two types of materials:

- 1) a grass strip above the stone threshold,
- 2) a grass strip below the stone threshold,
- or 3) grass strips both above and below the stone threshold.

Channel with three stone thresholds

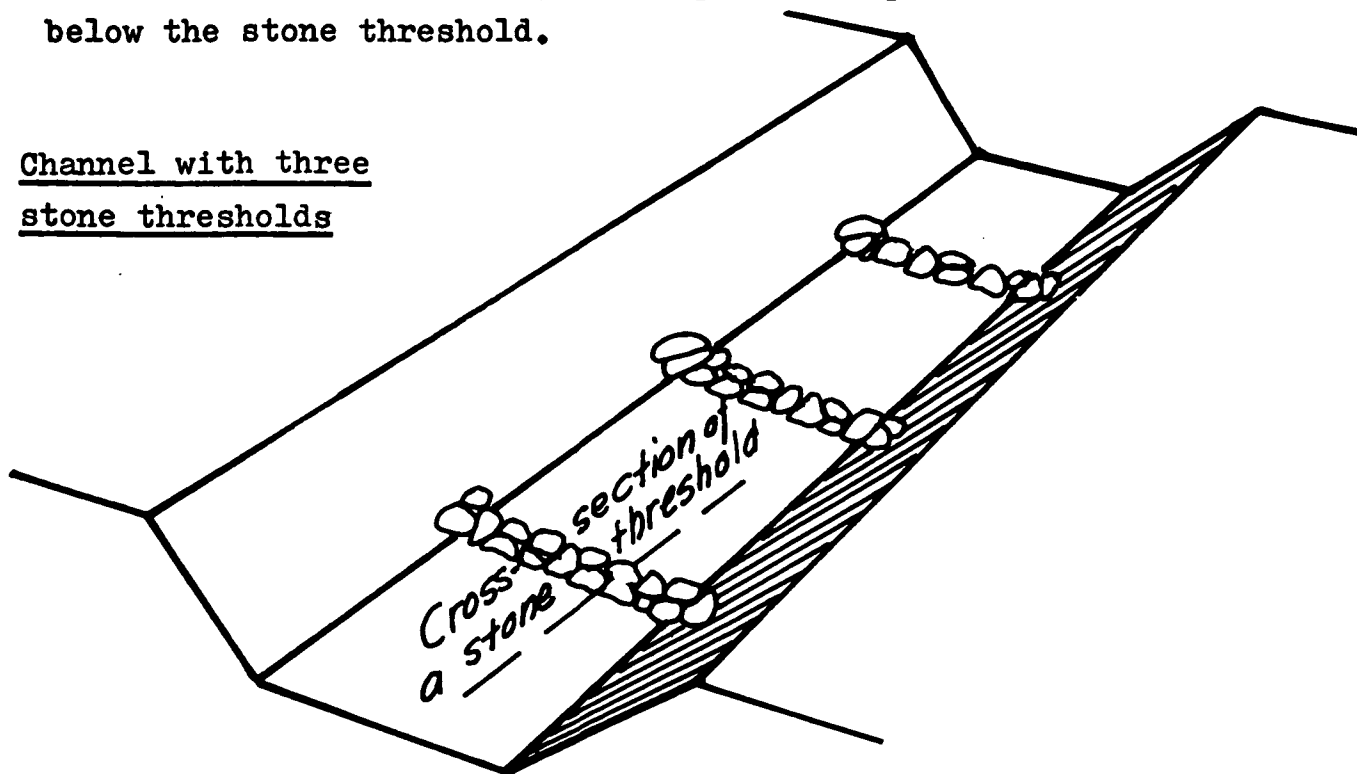

Cross-sections of stone thresholds



*without strips of sods*



*Strip of sods below*

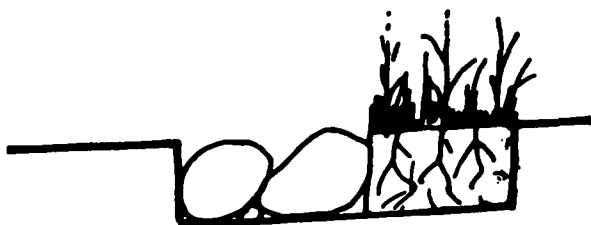

*Strip of sods above*

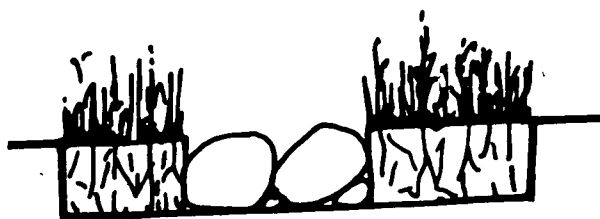

*Strips of sods below and above*

Floor of a gully, narrow and steep

In steep and narrow gullies the check dams have to be more solid to reduce the fall of the slope and to resist the velocity of the water. Both ends of a check dam should be somewhat higher to prevent water from cutting round them. It is better to construct several low dams than a few high dams. The filled-up dams (steps of silt) should have a small percentage inclination. Consequently the number of check dams depends on the gradient of the gully (see the table below).

Table showing spacings in metres between check dams

Gradient %	Height of check dam							
	0.3 m		0.6 m		0.9 m		1.2 m	
2	15		30		45		60	
4	15		30		45		60	
6	7.5		15		23		30	
8	5.2		10.3		15		20	
10	4.0		7.7		11.5		15	
12	3.2		6.3		9.3		12	
14	2.7		5.3		7.8		10	
16	2.3		4.6		a)6.7 b)7.4	a)8.9	b)10.0	
20	1.8		a)3.7 b)4.5		5.4 6.7	7.1	8.5	
24	1.7		3.1 3.9		4.5 6.1	5.9	8.0	
28	a)1.4 b)1.7		2.7 3.4		3.9 5.4	5.1	6.6	
32	1.2 1.6		2.3 3.2		3.3 4.6	4.3	6.0	
36	1.1 1.5		2.1 3.0		3.0 4.4	3.9	5.7	
40	1.0 1.3		1.9 2.9		2.7 4.2	3.5	5.5	
44	0.9 1.2		1.7 2.8		2.4 4.0	3.1	5.2	

a) wood and gabion constructions b) stone wall with slopes 1:1

Wooden material (if stones are not available)

For detailed design see the next page

View of an eroded channel

with two wooden  
check dams

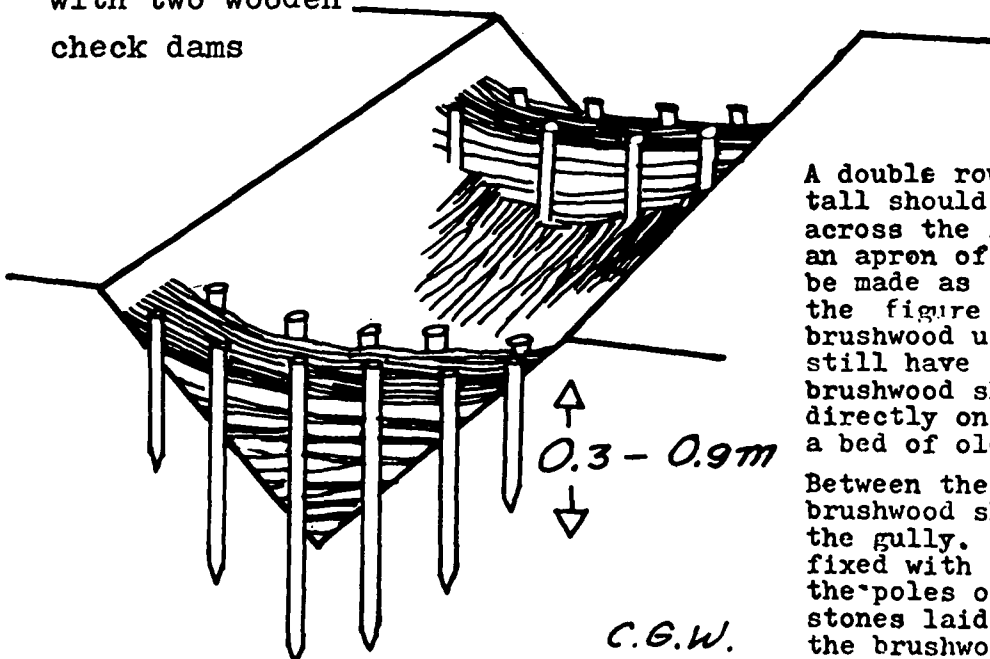

A double row of poles 5-6 feet tall should be hammered down across the floor. After that an apron of brushwood should be made as can be seen from the figure on the left. The brushwood used should preferably still have its leaves on. The brushwood should not be laid directly on the ground but on a bed of old grass or weeds.

Between the rows of poles brushwood should be laid across the gully. The brushwood can be fixed with a wire connecting the poles or with large flat stones laid on the surface of the brushwood fill.

CHECK DAM USING WOODEN MATERIAL

View across the valley

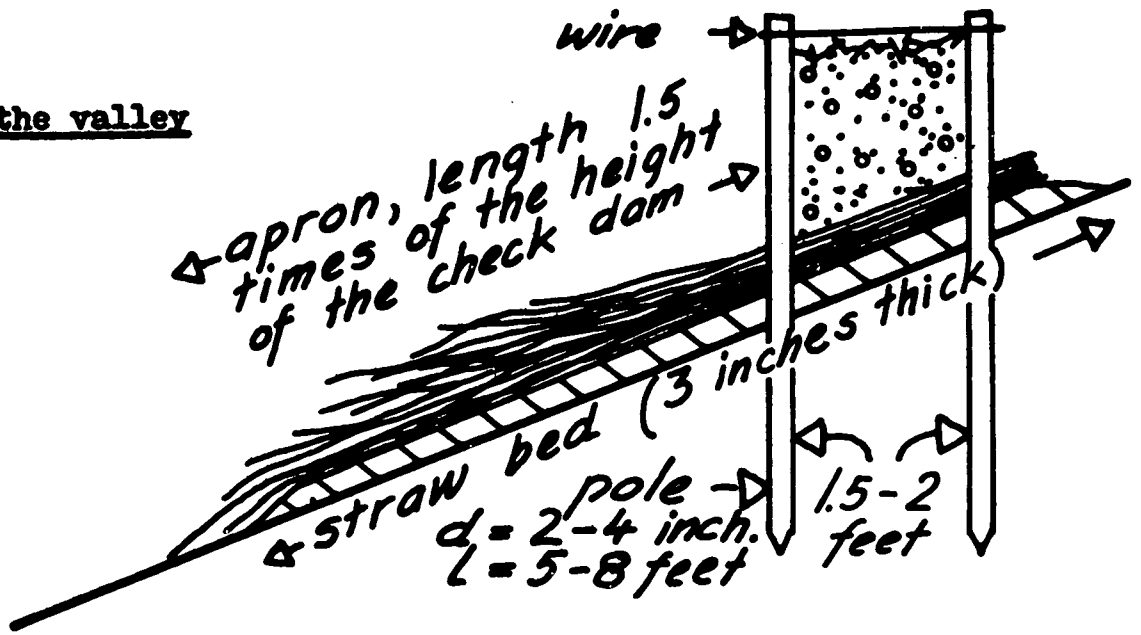

View from above

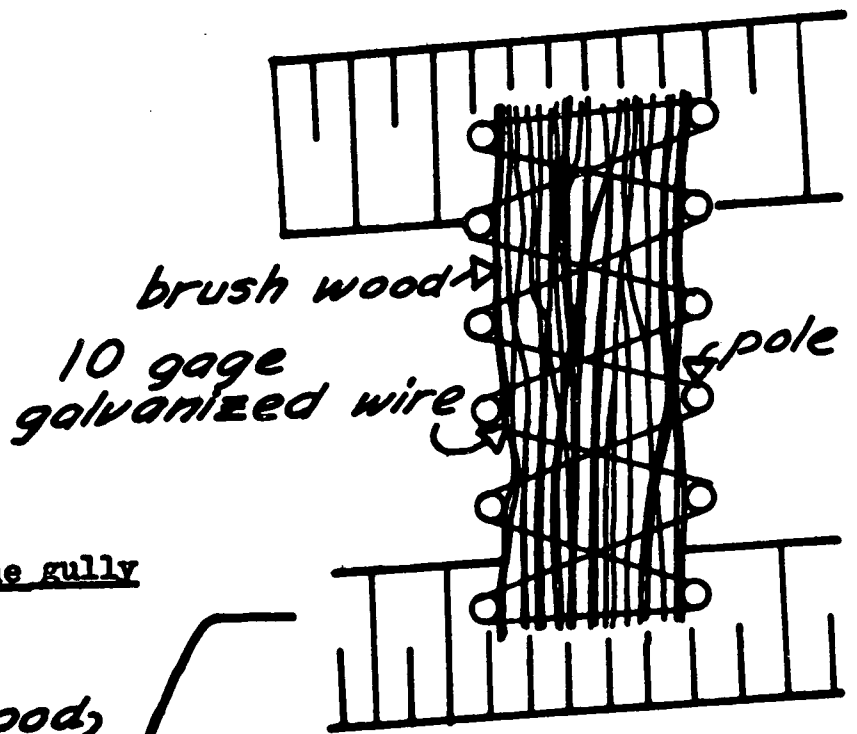

View in the direction of the gully

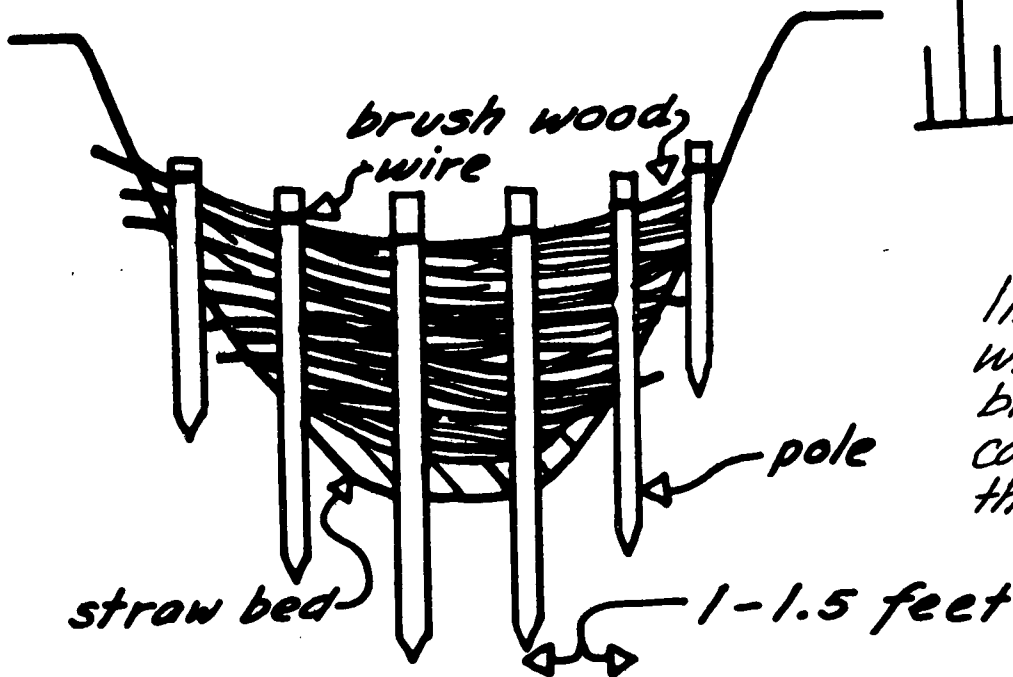

Instead of using wire to fix the brushwood, boulders can be put upon the brush.

Stone material, large stones available

CHECK DAM USING STONE MATERIAL

View of a gully with  
a check dam

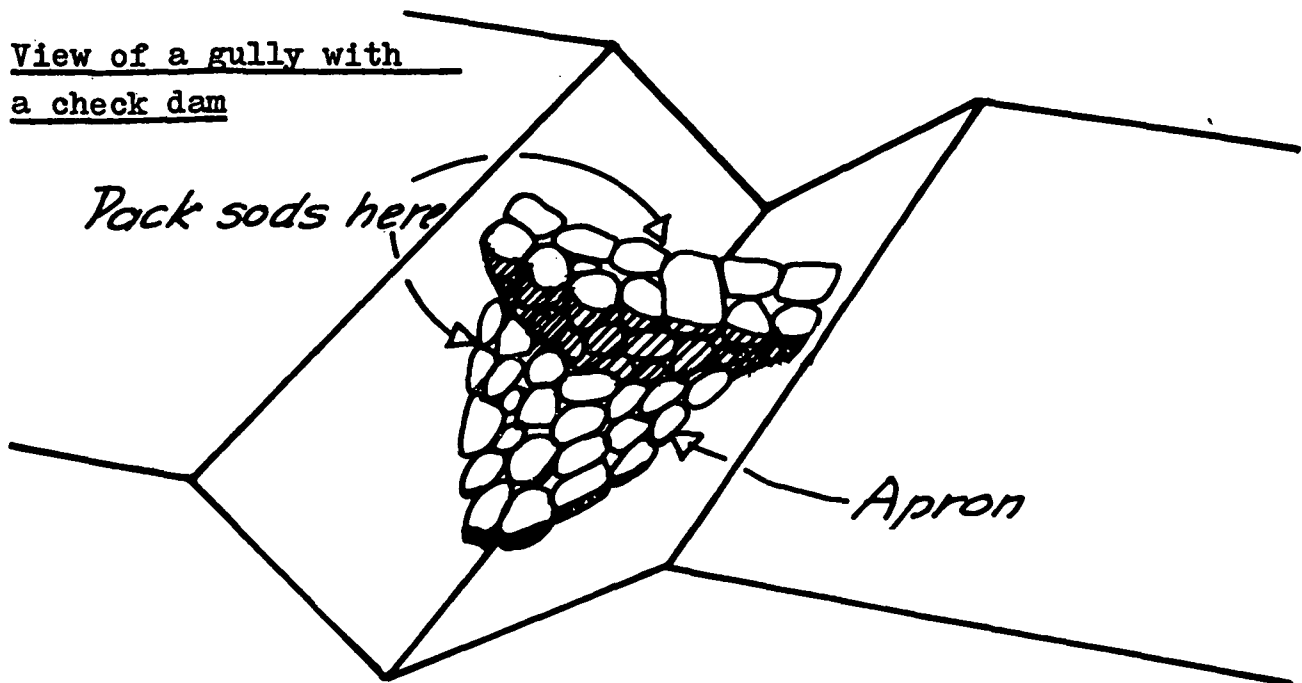

Cross-section  
of a check dam

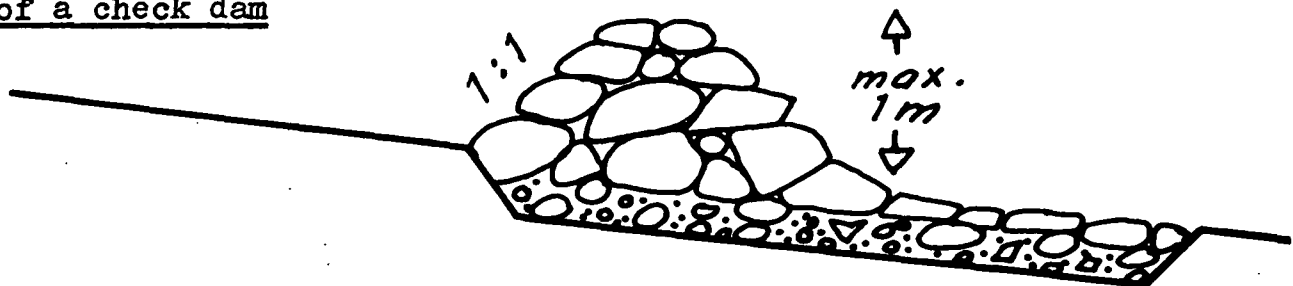

C.G.W.

Construction work should start with a shallow excavation, 0.5-1 feet deep, across the floor. The bottom of the excavation should be covered with a layer of gravel, pebbles and small stones. Above this layer the largest boulders and stones are laid as a ridge across the floor. Small stones and pebbles should fill up the spaces in the ridge to create stable slopes on both sides of the ridge. Stone check dams should not be higher than 0.5-1 m, in the latter case 1.5 m wide at the bottom and 0.5 m wide at the top. Below the stone ridge there should be an apron of large flat stones of the same width as the ridge. This apron should also be laid on excavated ground as shown in the figure above. The length of the excavated trench is 1.3-1.7 times the height of the ridge.

Stone material, large stones not available

In such a case gabions can be used (see the example below). Gabions can be made by the staff (see the following two pages), or they can be bought prefabricated. However, they tend to be expensive. The following are examples of sizes and prices (Greenham Ltd, Nairobi in 1979):

Gabions 2 x 1 x 1 m with one central diaphragma	shs. 335
2 x 1 x 0.5 m with one central diaphragma	shs. 215
Mattresses 6 x 2 x 0.23 m with nine diaphragma at 0.6 m intervals	shs. 745
Mattresses 6 x 2 x 0.29 m with nine diaphragma at 0.6 m intervals	shs. 765

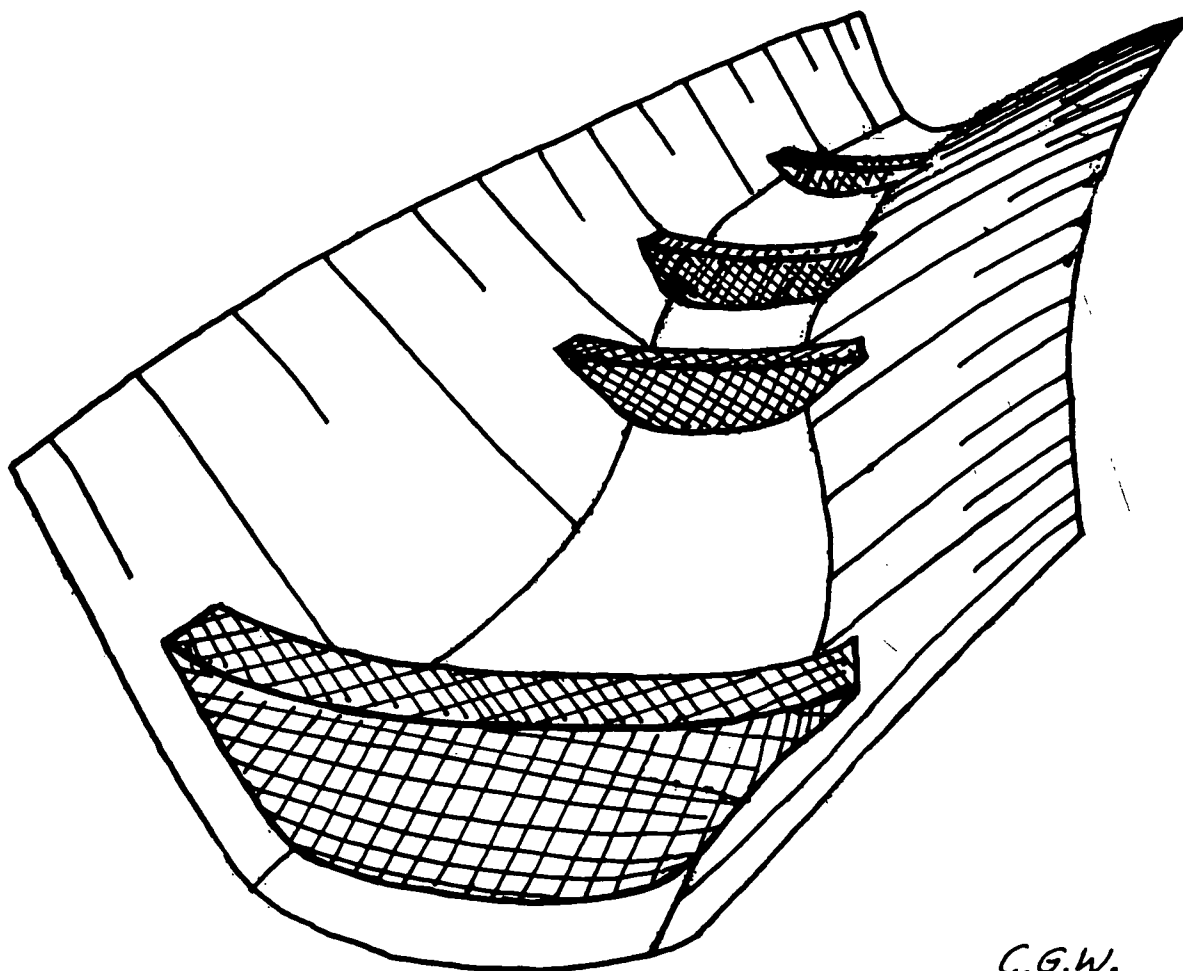

C.G.W.



### Gabions

Gabions are boxes of galvanized wire mesh. Such boxes can be filled even with small stones, and the mesh will prevent a water flow from removing the stones. The boxes are heavy enough to resist movement even by large water flows and high stream velocities. Unlike concrete they do not crack.

Fabrication should be done on the site as shown below:

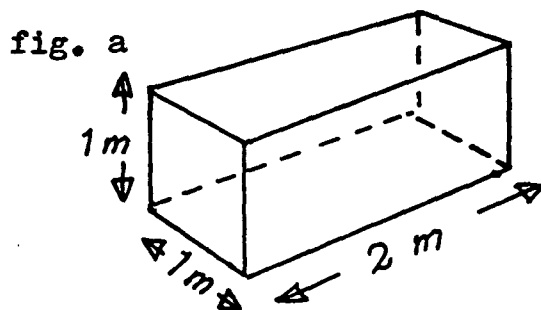

Example of size 2 x 1 x 1 m (fig.a)

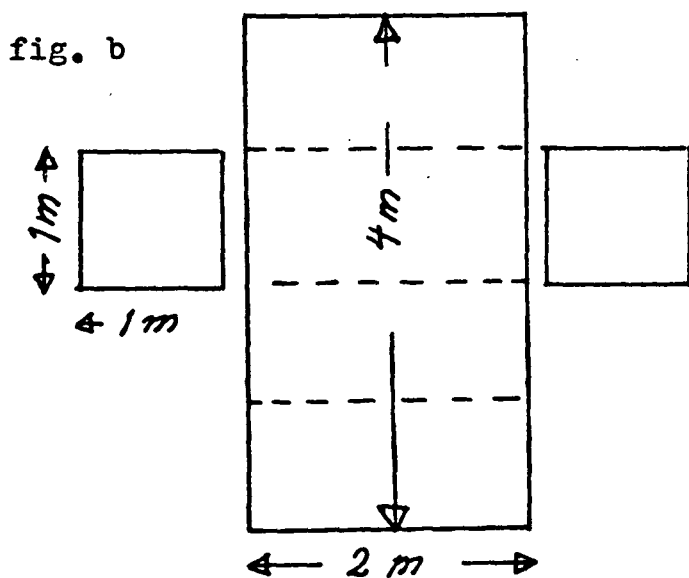

This size needs (fig.b):

a) for 4 sides  $4 \times 2 \text{ m} = 8 \text{ sq.m}$  of wire mesh

b) for 2 ends 2 pieces of  $1 \times 1 \text{ m} = 2 \text{ sq.m}$ .

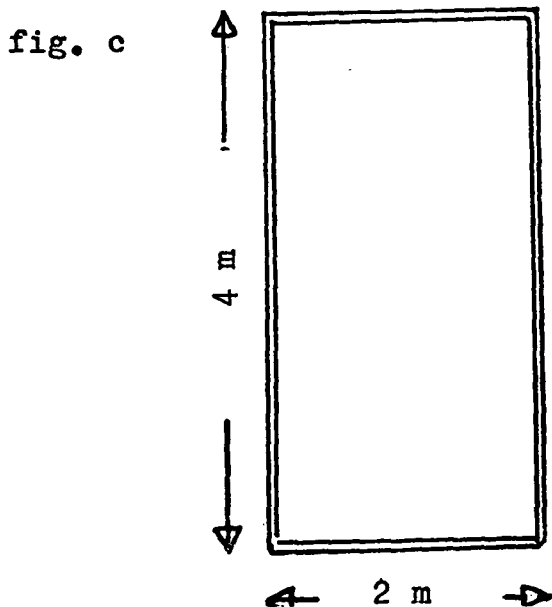

An iron rod ( $d = 5 - 7 \text{ mm}$ ) is needed for reinforcement round the 4 sides =  $4 + 2 + 4 + 2 = 12 \text{ m}$  (fig. c and d).

fig. d

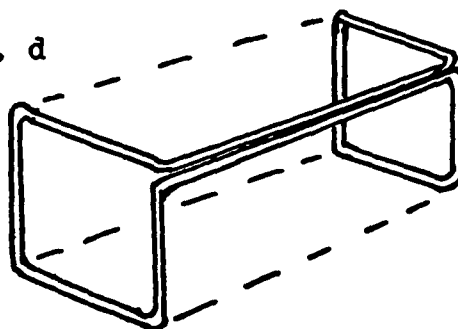
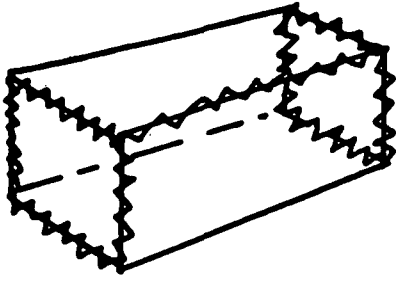
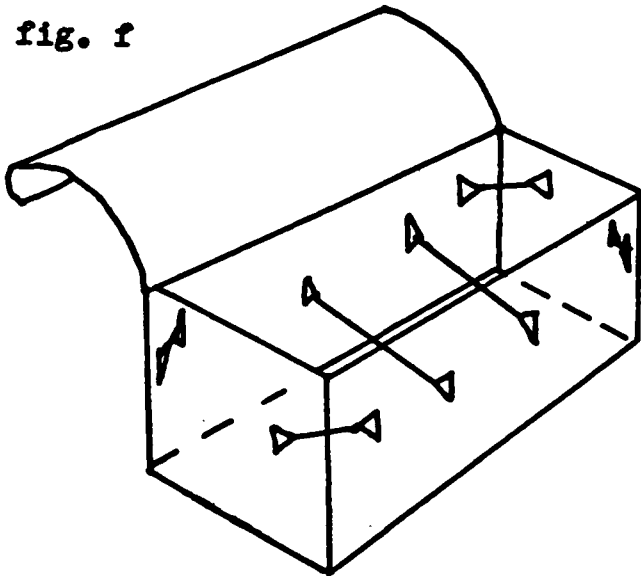

fig. e



For "sewing" the wire mesh into the box approx. 10 m of wire is needed (fig. e).

fig. f



During the filling of the gabion box with stones, cross-ties can help to stabilize the box, the ties being across the box, as well as diagonally in the corners (fig. f).

Fill the gabion with stones to  $1/2$  (or  $1/3$ ) of the height. Fix the horizontal cross-ties above the level of the stone filling. Repeat filling (and cross-ties). The level of the filled up gabion box can be 1 - 2 inches too high to allow some settlement.

If several gabions are placed beside or on top of each other, they should be connected by thick galvanized wire. Gabions should be laid in small excavations in the ground to prevent undercutting by erosion.

Side walls of a gully

There is usually no reason to make the side walls less steep through digging. This will happen by itself, and when the side walls start to stabilize, vegetation will appear by itself. However, if the walls are not very steep, stabilization can be helped by planting trees and/or grass.

Bank erosion in a bend, wooden materials used

Sometimes the water flow erodes the bend of a gully. In a small gully this can be stopped by a row of poles with brushwood between the poles and the gully wall. However, in a large gully (or river) the construction has to be stronger. See design below and on the next page.

View from above

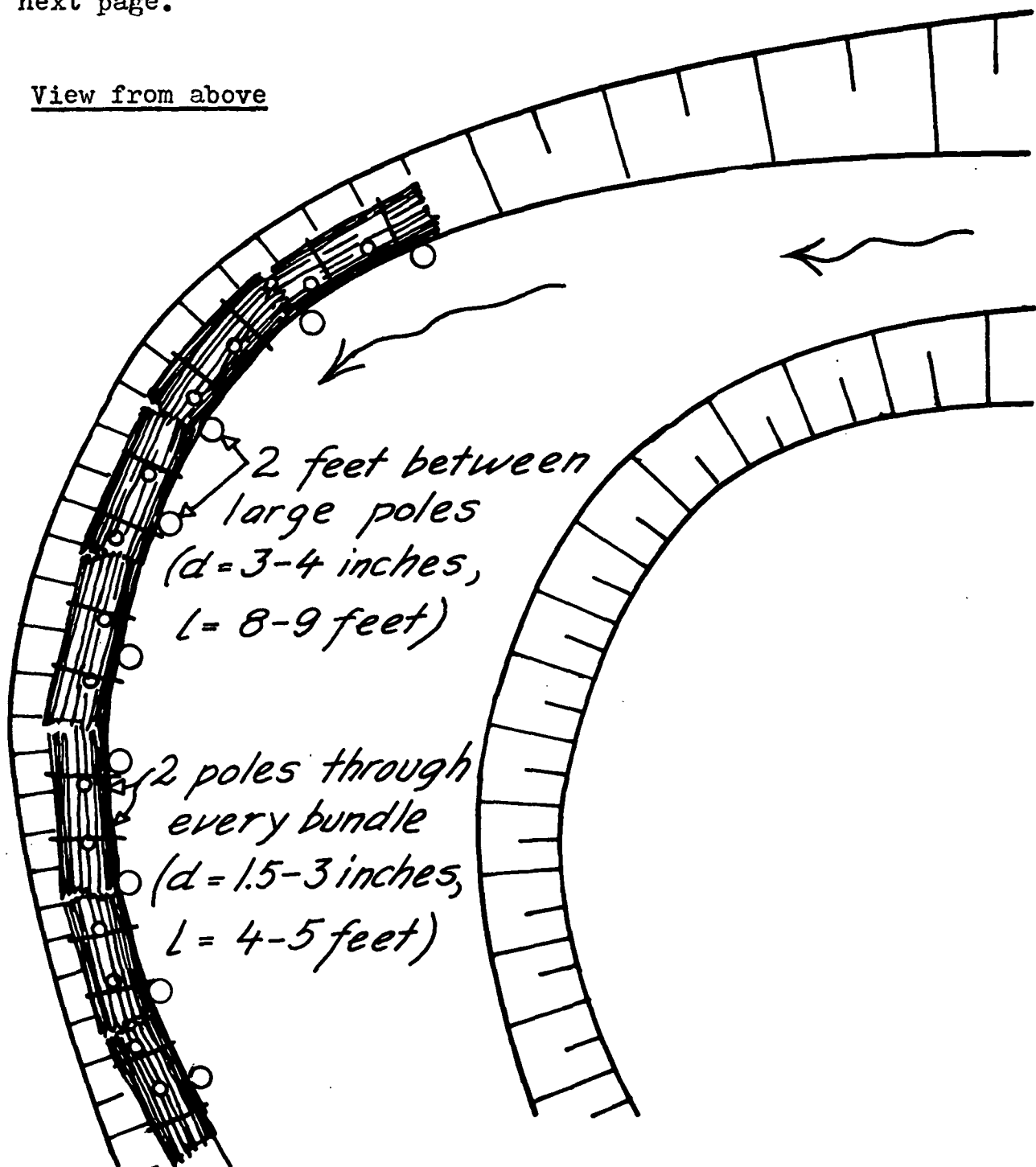

View along the bank

View towards the bank

4 bundles of  
brush wood  
(h = 12-16 inch.  
L = 3-4 feet)

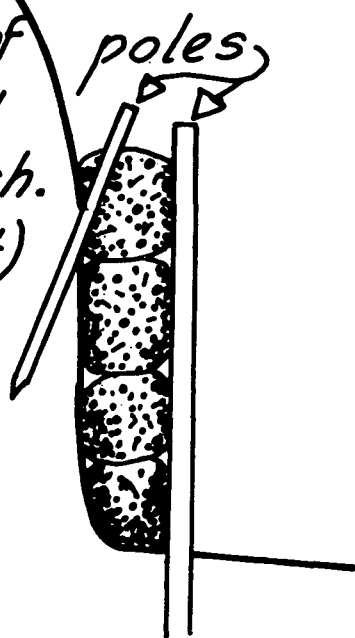

boulder 2 feet

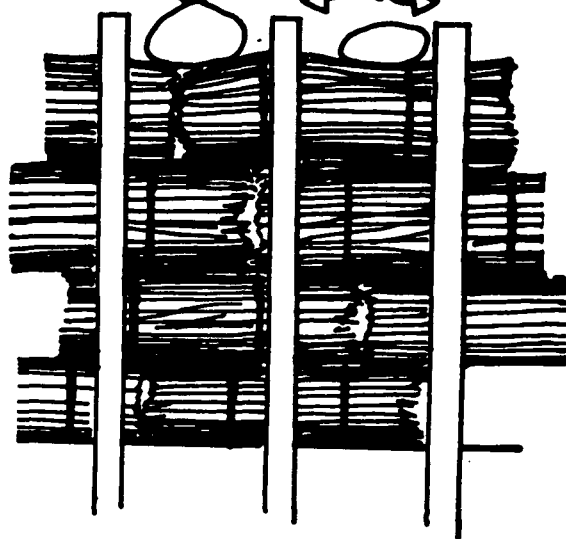

Bank erosion in a bend, gabions used

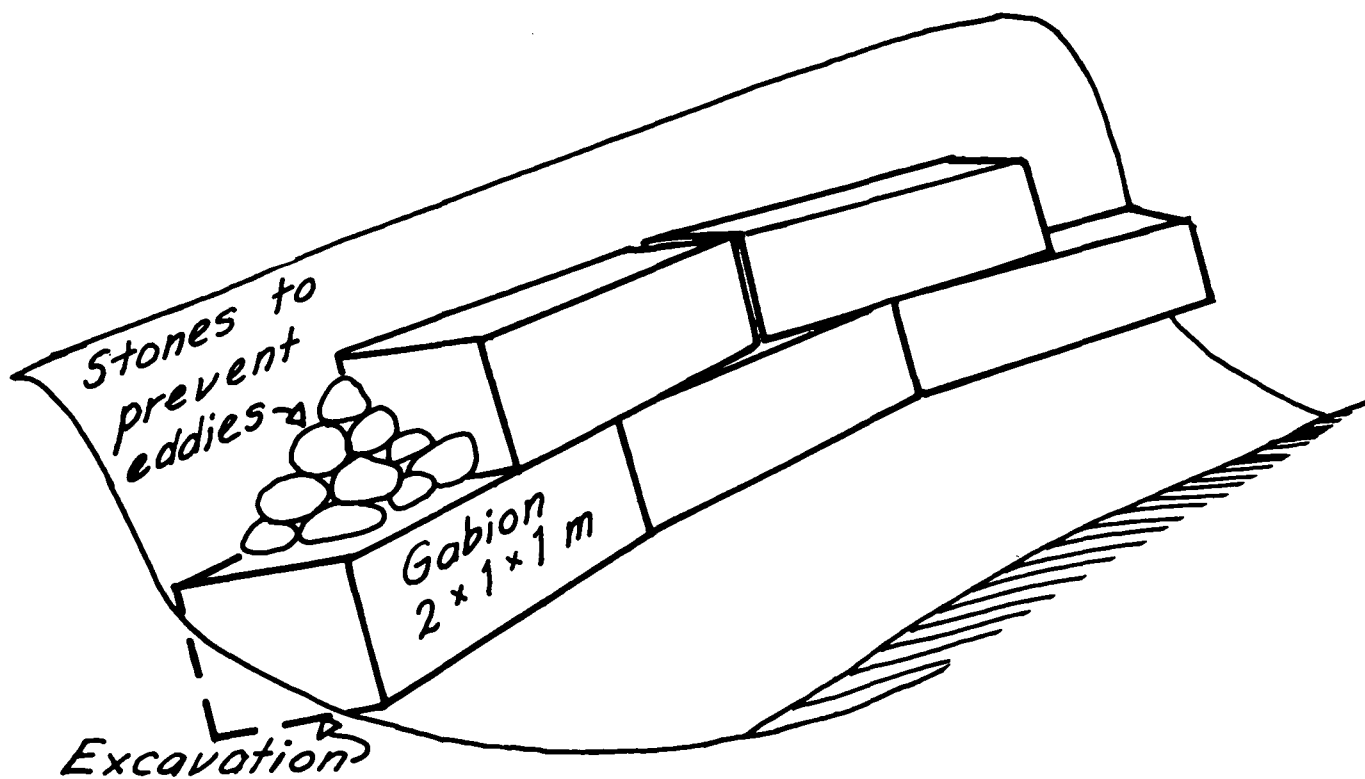

C.G.W.

## APPENDIX NO. 2

### GRASS SPECIES

#### MENTIONED IN THE HANDOUT

	pages
1. <i>Cenchrus ciliaris</i> (Buffel Grass)	2
2. <i>Chloris gayana</i> (Rhodes Grass)	2
3. <i>Cynodon dactylon</i> (Star Grass)	2
4. <i>Enteropogon macrostachyus</i> (Bush Rye)	3
5. <i>Eragrostis cilianensis</i> (Grey Lovegrass)	3
6. <i>Eragrostis superba</i> (Masai Lovegrass)	3
7. <i>Hyparrhenia rufa</i>	4
8. <i>Latipes senegalensis</i> (Hook Grass)	4
9. <i>Panicum coloratum</i> (Coloured Guinea Grass)	4
10. <i>Panicum maximum</i> (Guinea Grass)	5
11. <i>Paspalum notatum</i> (Bahia Grass)	5
12. <i>Pennisetum clandestinum</i> (Kikuyu Grass)	5
13. <i>Pennisetum purpureum</i> (Napier Grass)	6
14. <i>Setaria sphacelata</i> (Common Setaria)	6
15. <i>Themeda triandra</i> (Red Oat Grass)	6
16. <i>Botriochloa insculpta</i> (Creeping Bluegrass)	7

The pictures have been reprinted from:

1. Bogdan and Pratt: Reseeding denuded pastoral land in Kenya, 1967
2. Fröman and Persson: An illustrated guide to the grasses of Ethiopia, 1974
3. Royal Botanic Gardens: East African pasture plants, I and II, 1926 and 1927
4. Bisset, W.J. and Graham, T.G.: Creeping bluegrass finds favour, Queensland Agricultural Journal, Maj-June 1978.



1. *Cenchrus ciliaris*  
(African Foxtail  
or Buffel Grass)



2. *Chloris gayana*  
(Rhodes Grass)



3. *Cynodon dactylon*  
(Star grass)

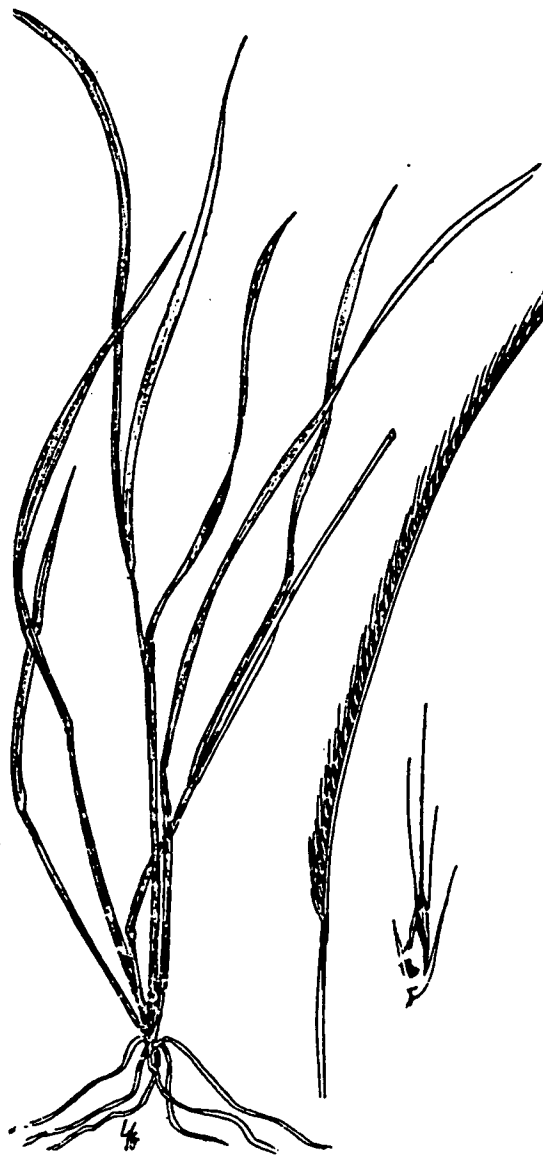

4. *Enteropogon machrestachyus*  
(Bush Rye)



5. *Eragrostis cilianensis*  
(Grey Lovegrass)



6. *Eragrostis superba*  
(Masai Lovegrass)



7. *Hyparrhenia rufa*



8. *Latipes senegalensis*  
( Hook Grass)



9. *Panicum coloratum*  
( Coloured Guinea Grass)





10. *Panicum maximum*  
(Guinea Grass)



11. *Paspalum notatum*  
(Bahia Grass)



12. *Pennisetum clandestinum*  
(Kikuyu Grass)

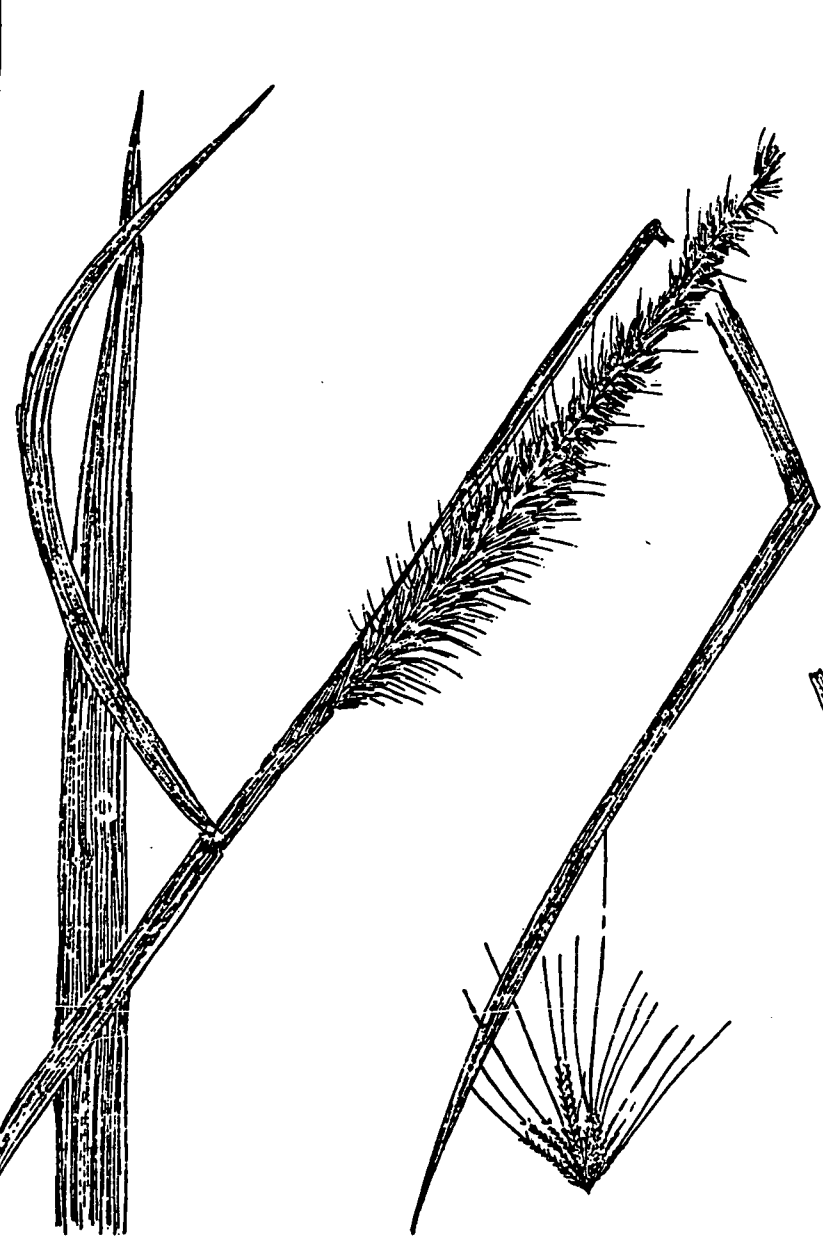

13. *Pennisetum purpureum*  
(Napier Grass)



14. *Setaria sphacelata*  
(Common Setaria)

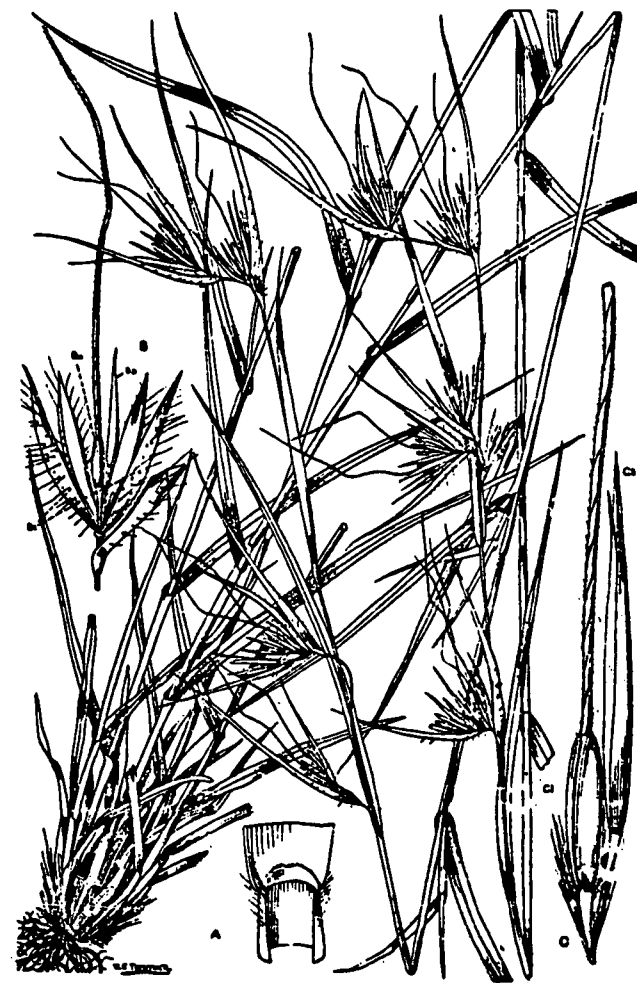

15. *Themeda triandra*  
(Red Oat Grass)

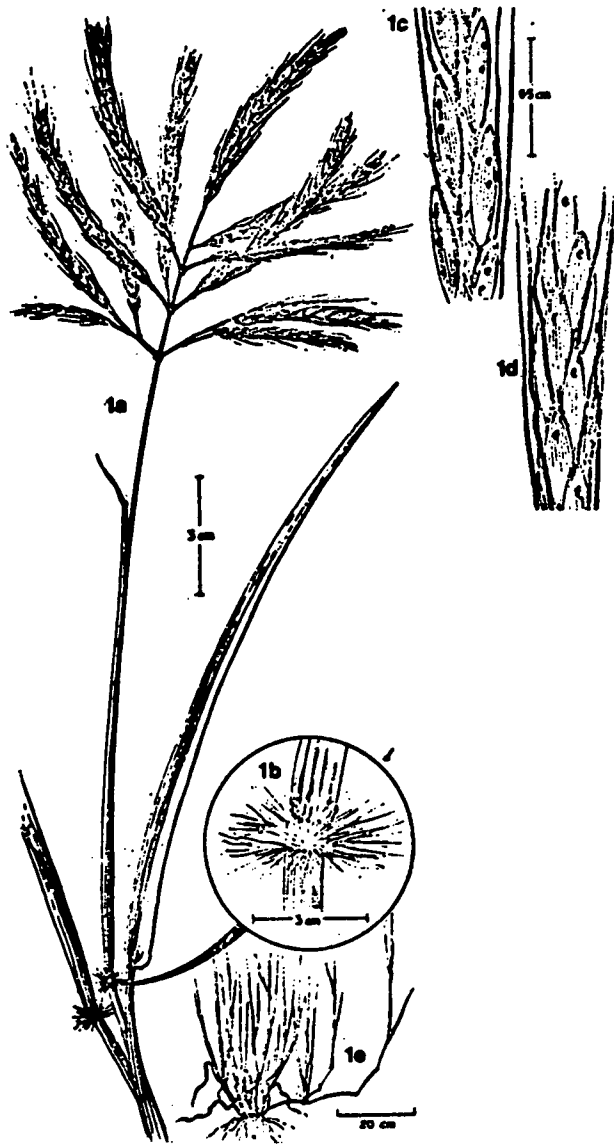

16. *Botriochloa insculpta*  
(Creeping Bluegrass)

APPENDIX NO. 3

TREE SPECIES

OF DRY AREAS, MENTIONED IN THE HANDOUT

	pages
1. Acacia albida (Apple Ring Acacia)	2
2. Leucaena leucocephala (Leucena)	2
3. Prosopis juliflora (Algaroba)	3
4. Azadirachta indica (Neem tree)	3
5. Cassia Siamea (Cassia)	3

The pictures have been reprinted from:

1. National Academy of Sciences, Washington:

Leucaena promising forage and tree crop for the tropics,  
Washington 1977

2. Skerman, P.J. Tropical forage legumes. - FAO, Rome 1977

3. Weber, F.R.: Reforestation in arid lands. - Volunteers  
in Technical Assistance, Vita Publications, Manual  
Series No. 37 E, Mt. Rainier, MD, USA



1. *Acacia albida*  
(Apple Ring Acacia)

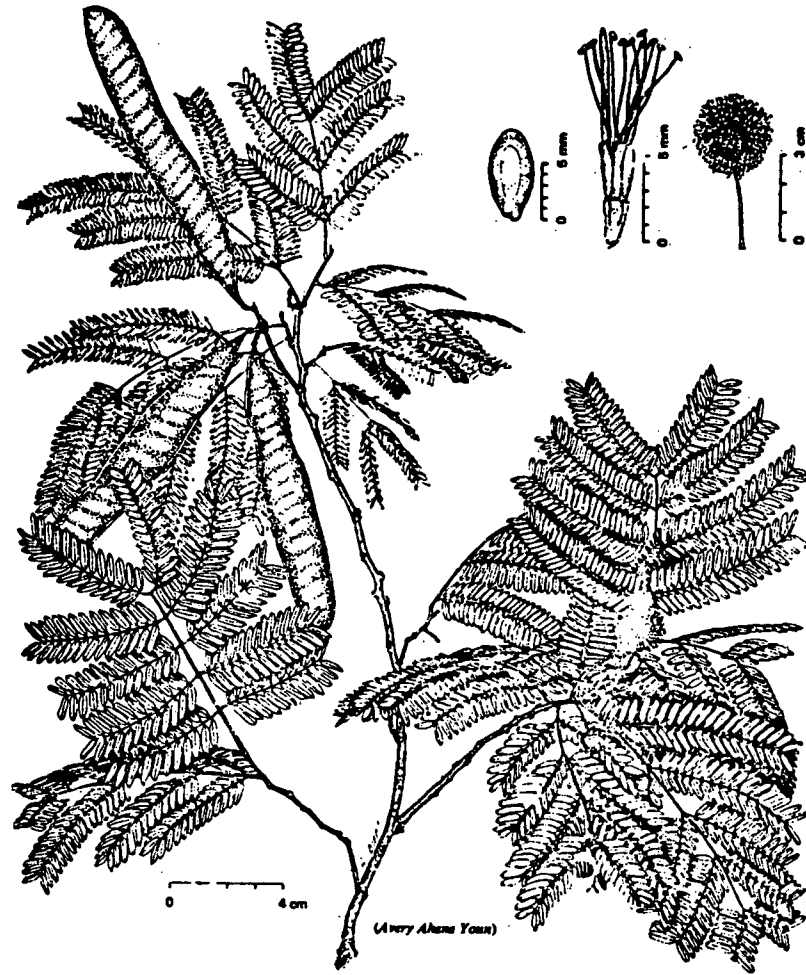

2. *Leucaena leucocephala*  
(Leucena)

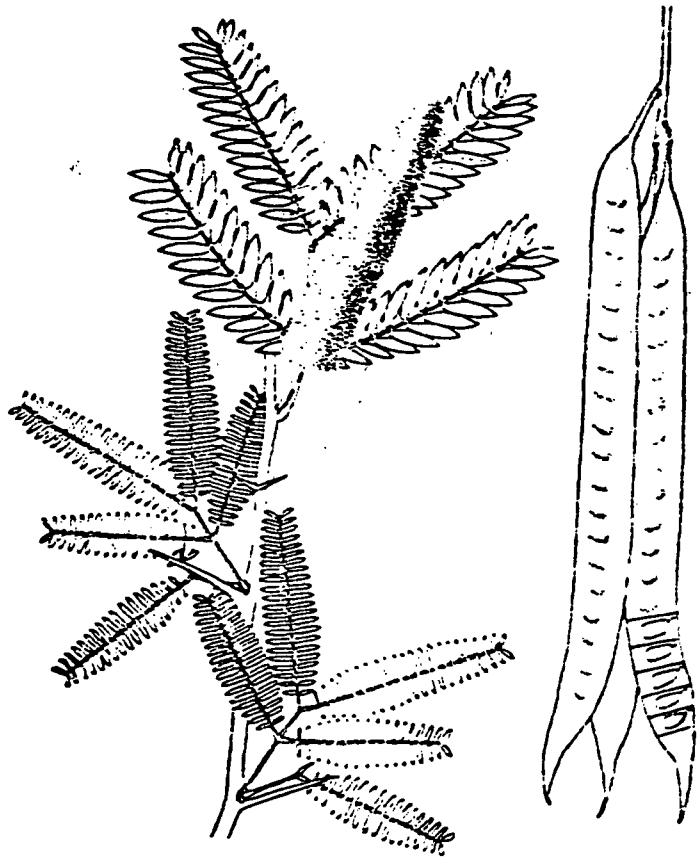

3. *Prosopis juliflora*  
(Algaroba)



4. *Azadirachta indica*  
(Neem tree)

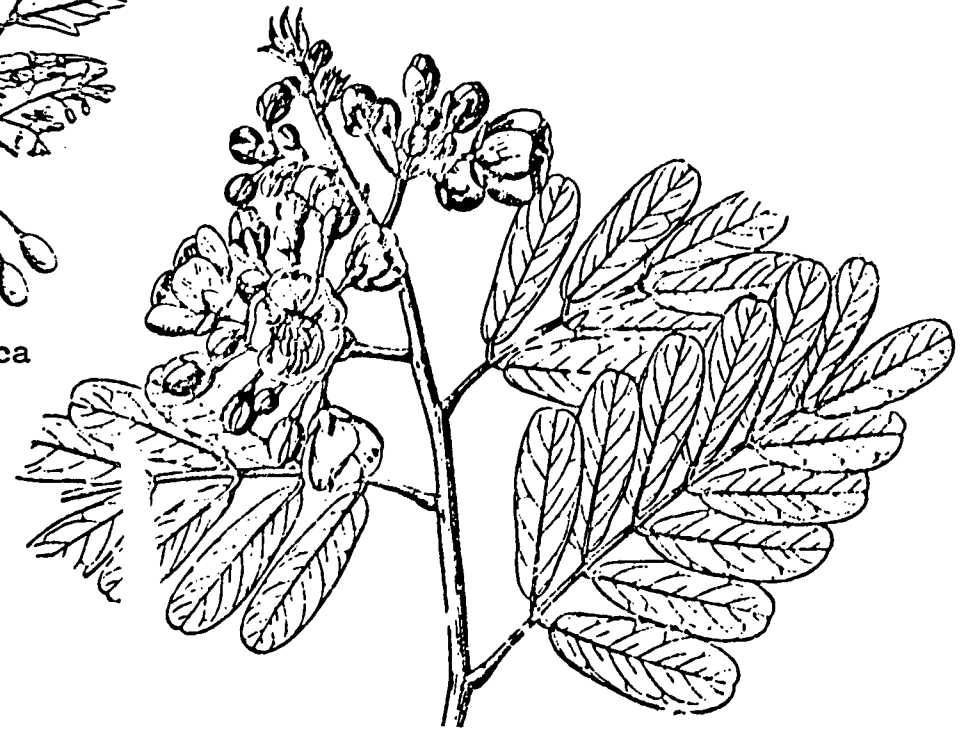

5. *Cassia Siamea*  
(Cassia)

APPENDIX NO. 4  
CONVERSION TABLES

	pages
1. Common metric conversion	2
2. Conversion tables for:	
length, area and volume	3
weight and yield	4

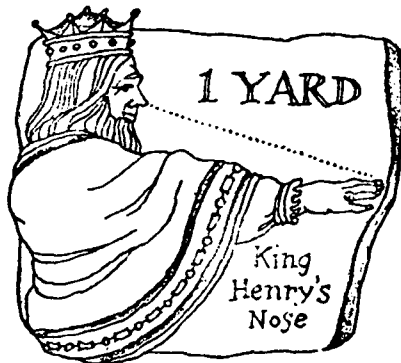

The *mètre*, as approved by the French National Convention in 1795, was to be one ten-millionth of the length of earth's meridian between the Equator and the North Pole.

The figures have been reprinted from:

1. Weaver, K.F.: How soon will we measure in metric, National Geographic, 1977.
2. Mortensen, E. and Bullard, E.T.: Handbook of tropical and subtropical horticulture. - Division of Agriculture, US A.I.D. to Haiti, Washington 1966.

COMMON METRIC CONVERSION

	<u>If you know</u>	<u>Multiply by</u>	<u>To find</u>
length	inches	25.4	=millimeters
	feet	0.305	=meters
	yards	0.914	=meters
	miles	1.609	=kilometers
area	square feet	0.093	=square meters
	square yards	0.836	=square meters
	acres	0.405	=hectares
volume	quarts (1q)	0.946	=liters
	cubic yards	0.765	=cubic meters
	cubic feet	28.33	=liters
	gallons	4.5435	=liters
	English gallons	1.2	=USA gallons
mass	ounces	28.35	=grams
	pounds	0.454	=kilograms
temperature	degrees Fahrenheit	$\frac{5}{9}$ (after subtracting 32)	=degrees Celcius

---

length	millimeters	0.039	=inches
	meters	3.281	=feet
	meters	1.094	=yards
	kilometers	0.621	=miles
area	square meters	1.196	=square yards
	hectares	2.471	=acres
volume	liters	0.2209	=gallons
	liters	1.057	=quarts
	cubic meters	1.308	=cubic yards
mass	grams	0.035	=ounces
	kilograms	2.205	=pounds
temperature	degrees Celcius	$\frac{9}{5}$ (then add 32)	=degrees Fahrenheit



CONVERSION TABLES FOR LENGTH, AREA AND VOLUME

<u>LENGTH</u>			<u>VOLUME</u>		
<u>Metric</u>			<u>Metric</u>		
1 micron	=	0.001 millimeter	1 cubic millimeter	=	0.000,000,001 cu. meter
1 millimeter	=	0.001 meter	1 milliliter	=	0.03382 fluid ounce
	=	0.0394 inch		=	0.001 liter
1 centimeter	=	10 millimeters	1 centiliter	=	0.01 liter
	=	0.3937 inch		=	0.61 cubic inch
	=	0.01 meter	1 liter	=	33.82 fluid ounces
1 meter	=	39.37 inches		=	2.113 U.S. pints liquid
	=	3.281 feet		=	1.057 U.S. quarts liquid
	=	1,000 millimeters		=	0.9081 quart, dry
	=	100 centimeters		=	0.2642 U.S. gallon
1 kilometer	=	3,281 feet		=	0.11351 U.S. peck
	=	1,094 yards		=	1,000 Imperial gallon
	=	0.621 mile		=	0.0353 milliliters or cc.
	=	1,000 meters		=	61.02 cubic foot
				=	0.01 cubic inches
<u>Imperial</u>			1 cubic centimeter	=	0.061 cubic inch
1 inch	=	25.4 millimeters		=	1,000 cubic millimeters
	=	2.54 centimeters	1 hectoliter	=	100 liters
1 foot	=	30.48 centimeters		=	2.8378 bushels
	=	0.3048 meter	1 cubic meter	=	61,023.38 cubic inches
	=	12 inches		=	35.314 cubic feet
1 yard	=	0.9144 meter		=	1.308 cubic yards
	=	91.44 centimeters		=	264.17 U.S. gallons
	=	3 feet		=	1,000 liters
	=	4.525 links		=	28.38 U.S. bushels
1 mile	=	1,609.347 meters		=	1,000,000 cu. centimeters
	=	1.609 kilometers		=	1,000,000,000 cu. millimeters
	=	5,280 feet	1 cubic kilometer	=	1,307,942,000 cu. yards
	=	1,760 yards	<u>Imperial</u>		
			1 cubic inch	=	16.387 cubic centimeters
			1 cubic foot	=	28,317 cubic centimeters
				=	0.0283 cubic meter
				=	28.316 liters
				=	7.481 U.S. gallons
				=	1,728 cubic inches
<u>Metric</u>			1 U.S. gallon	=	16 cups
1 square centimeter	=	0.155 sq. in.		=	3.785 liters or cc.
	=	100 sq. millimeters		=	231 cubic inches
1 square meter	=	1,550 sq. inches		=	4 U.S. quarts
	=	10.764 sq. feet		=	8 U.S. pints
	=	1.196 sq. yards		=	8.3453 pounds of water
	=	10,000 sq. centimeters		=	128 fluid ounces
1 square kilometer	=	0.3861 sq. mile		=	0.8327 British Imperial gallon
	=	254.427 cuerdas	1 British Imperial gallon	=	4.546 liters
	=	1,000 sq. meters		=	1.201 U.S. gallons
1 are	=	100 sq. meters		=	277.42 cubic inches
	=	0.01 hectare	1 cubic yard	=	0.7646 cubic meter
	=	0.0247 acre		=	46,056 cubic inches
1 hectare	=	2.471 acres		=	27 cubic feet
	=	0.775 carreau	1 U.S. bushel	=	35.24 liters
	=	10,000,000 sq. meters		=	0.3524 hectoliter
	=	100 ares		=	2,150.42 cubic inches
				=	1,244.4 cubic feet
				=	0.03524 cubic meter
<u>Imperial</u>				=	2 pecks
1 square foot	=	929.088 sq. cm.		=	32 quarts
	=	0.0929 sq. meter		=	64 pints
1 square yard	=	8,361.3 sq. cm.	1 barrel	=	7,056 cubic inches
	=	0.8361 sq. meter		=	105 dry quarts
	=	1,296 sq. inches		=	115.626 liters
	=	9 sq. feet	1 U.K. bushel	=	2,219.36 cubic inches
1 square mile	=	2.59 sq. km.		=	36.37 liters
	=	102,400 sq. rods			
	=	658.98 cuerdas			
	=	640 acres			
1 acre	=	0.4047 hectare			
	=	0.3135 carreau			
	=	43,560 sq. feet			
	=	4,840 sq. yards			
	=	4,046.87 sq. meters			

CONVERSION TABLES FOR WEIGHT AND YIELD

WEIGHT

Metric

1 milligram	=	0.001	gram
	=	0.0154	grain
1 centigram	=	0.01	gram
	=	0.1543	grain
1 gram	=	0.0353	avoirdupois ounce
	=	15.4324	grains
1 hectogram	=	100	grams
	=	3.53	avoirdupois ounces
	=	1,543.24	grains
1 kilogram	=	1,000	grams
	=	353	avoirdupois ounces
	=	2,204.6	avoirdupois pounds
	=	10	hectograms
1 quintal (metric)	=	100	kilograms
	=	220.46	pounds
1 metric ton	=	1,000	kilograms
	=	2,204.6	pounds
	=	1.102	short tons
	=	0.984	long ton

Imperial

1 grain	=	1/7000	avoirdupois pound
	=	0.064799	gram
1 ounce (avoirdupois)	=	28.3496	grams
	=	437.5	grains
	=	1/16	pound
1 pound (avoirdupois)	=	453.593	grams
	=	0.453 <sup>49</sup> / <sub>5</sub>	kilograms
	=	16	ounces
1 stone	=	14	pounds
	=	6.350	kilograms

YIELD

Metric

1 kilogram per hectare	=	0.89	pound per acre
1 hectoliter per hectare	=	68.88	pounds per acre
	=	1.148	bushels (60 pounds) per acre
1 quintal per hectare	=	89.214	pounds per acre
	=	1.4869	bushels (60 pounds) per acre
	=	100	kilograms per hectare
	=	0.446	ton (2,000 lb.) per acre

Imperial

1 pound per acre	=	1.121	kilograms per hectare
1 bushel (60 pounds) per acre	=	0.871	hectoliter per hectare
	=	67.26	kilograms per hectare
1 ton (2,000 lb.) per acre	=	2.242	metric tons per hectare